

OWNER'S MANUAL

**CAPE
DORY
YACHTS**



INCORPORATED

CAPE DORY

270

Edited by: Catherine Monaghan, 2007

LETTER OF WELCOME

Dear Skipper:

Welcome to the Cape Dory fleet!

You have joined the select group of sailors who recognize the quality construction and traditional workmanship found in every Cape Dory yacht.

This manual has been prepared to assist you in getting to know your new yacht before setting sail for the first time. It also is a helpful guide to follow for proper care and maintenance in the future.

The Cape Dory team of managers, supervisors, and quality control personnel do their very best through every step of the construction process and strive to build boats of exceptional quality which will provide their owners with many years of sailing pleasure and retain a high resale value.

Please review the material carefully. You will enjoy your new Cape Dory more if you are familiar with the design and construction of the yacht and with the equipment used on board.

Any questions you may have can be answered by your authorized dealer as he is a knowledgeable professional and is familiar with your new boat. He will continue to be your most important contact for information about your boat and for any problems should they develop.

We appreciate your confidence in our product and assure you that with proper care, you should have many years and miles of enjoyable sailing in your new Cape Dory.

Again, welcome to the fleet. May the wind always be fair.

Sincerely,

Andrew C. Vavolotis
President
Cape Dory Yachts, Inc.

TABLE OF CONTENTS

FORWARD & DISCLAIMER	6
CUSTOMER SERVICE	7
OWNERS RECORD	8
DEALER'S COMMISSIONING CHECKLIST	9
INTRODUCTION	13
CAPE DORY OWNERS ASSOCIATION	14
I. THE CAPE DORY OWNER	15
II. SAFETY	15
Charts	16
Fueling	16
Docking and Anchoring	18
III. LIMITED WARRANTY	19
Warranty Notification Procedures	20
IV. CAPE DORY 270 DESIGN	20
V. CONSTRUCTION	21
Hull	21
Deck and Headliner	21
Ballast	22
Rudder	22
Joiner Units and Bulkheads	23
VI. INTERIOR	23
VII. DIESEL AUXILIARY	24
Corrosion	25
Alignment and Shaft Assembly	26
Fuel System	27
VIII. ELECTRICAL SYSTEMS	29
DC System	29
Battery Voltage	30
AC System	31
Bonding System	32
Lightning Ground System	32
Electrolysis and Corrosion	33
IX. FRESH WATER SYSTEM	33
Pressure Water	34
Water Heater and Start Up	34
X. DRAINAGE SYSTEM	35

Thru Hulls and Seacocks	35
Scupper Drains	38
Bilge Pump	38
XI. HEAD AND WASTE SYSTEM	38
XII. CENTERBOARD SYSTEM	39
XIII. SPAR, RIGGING, AND SAILS	41
Standing Rigging	42
Turnbuckles	43
Running Rigging	44
Tuning the Standing Rigging	44
Deck Hardware and Chainplates	45
Chainplate System	45
Sails	46
Quick Reefing	48
Optional Sails	49
XIV. STEERING SYSTEM	49
Pedestal Steering	50
Edson Maintenance Guide	51
XV. EXTERIOR MAINTENANCE	52
Fiberglass	52
Surface Imperfections	52
Deep Scratches and Flaws	52
Non Skid Imperfections	53
Gel Coat Blisters	53
Bottom Paint and Boot Top Paint	53
Cove Stripe	54
Ports and Hatches	54
Deck Hardware	54
Winches and Blocks	55
Lifelines, Pulpits, and Stanchions	55
Spar	55
Standing Rigging	56
Sails	56
Centerboard	57
Teak	57
Leaks	58
XVI. INTERIOR MAINTENANCE	58
Wood Surfaces	59
Cushions	59
Ice Box	59
Ports and Hatches	60
Sinks	60
Head	60
Curtains	61
Stove	61
General	61

XVII. WINTERIZING	61
Blocking the Hull	61
Bottom Haulout	62
Propeller and Cutless Bearing	62
Engine	62
Fuel Tanks	62
Head	63
Electrical System	63
Scuppers and Seacocks	63
Ice Box	63
Bilge	63
Stove	63
Covering	63
Mast and Boom	64
XVIII. VENDOR PARTS LIST	65
XIX. VENDOR ADRESSES	69
XX. TECHNICAL INFORMATION	70
XXI. TECHNICAL REFERENCE DRAWINGS	71
1. Sail Plan	71
2. Arrangement	72
3. Starboard Elevation	73
4. Hull Deck Joint at Upper Shroud	74
5. Hull Deck Joint at Lower Shroud	75
6. Mast Step Detail	76
7. Stemhead Detail	77
8. Deck Hardware Layout	78
9. Steering System - Tiller	79
10. Steering System - Wheel	80
11. Spar Plan	81
12. Mainsheet Rigging Detail	82
13. Centerboard - System A	83
14. Centerboard - System B	84
15. Seacock Detail	85
16A. Fresh Water System	86
16B. Waste & Discharge System	87
17A. Fuel System	88
17B. Engine Cooling & Hot Water System	89
18. DC Panel Wiring	90
19A. 12 Volt DC Wiring	91
19B. 110 Volt AC Wiring	92
20. Lightning Ground & Underwater Bonding	93
21. Lifting Strap Location	94

FOREWORD & DISCLAIMER

This is a **modified** version of the 1984 Cape Dory Owner's Manual which was included with the vintage Cape Dory 270 sailboat built by Cape Dory Yachts, Inc., a company that ceased operations in 1991.

It is offered here for use by those seeking a replacement for their original owners manual or for any sailboat owner who might benefit from the useful information it contains on general sailboat maintenance and repair. It is not suggested that it be relied upon implicitly, but that it act as a supplement to other sources of information currently available.

References to people, companies and products mentioned within the Manual may now be obsolete; there is no longer a factory or Cape Dory Service Department to contact for support as the Manual states, no Dealers, no newsletter, etc.

Also, it should be kept in mind that the information in this Manual may be not only dated, but may contain inaccuracies or omissions and that neither I nor anyone connected with the original Manual shall be held liable for any losses, injuries, or damages arising from its use.

It was written and modified as a guide for owners of Cape Dorys specifically and its application and suitability for use with other types of boats is not expressed or implied. Further, it is meant to be distributed freely and not to be used for profit. All trademarks, logos, products and businesses appearing in the Manual are the sole property of their respective owners and they retain all rights. I have no association with and do not represent any of the products, businesses, or persons named in the Manual.

Cathy Monaghan, February 2007.

CUSTOMER SERVICE

The Cape Dory Yachts Customer Service Department has been established to provide technical information and a replacement parts ordering service for Cape Dory Owners.

Please do not hesitate to contact us with any questions or comments on your boat. We appreciate any suggestions that you might have to improve the product.

We suggest that you place any parts orders through your Cape Dory Dealer, but will be happy to accommodate you for special orders. Whenever you place an order, please provide the dealer or Cape Dory with your hull number and an accurate description of the part.

Situations may arise when we will be referring you to local marine stores or marine hardware manufacturers. Our intent in these cases is to provide you with the fastest and least expensive service.

Through our Customer Service Department, we strive to maintain our reputation for product quality and excellent service.

Sincerely,

Eric J. Brehm

Karla J. Zagrodny
Customer Service Department

CAPE DORY OWNER'S RECORD

Complete and save this form for your records and future reference.

Yacht Name _____ Home Port _____

Hull Identification Number * _____

Dealer Name _____ Address _____

Salesman. _____ Delivery Date _____

Date Commissioning Checklist/Warranty returned to CDY _____

* * * * *

Owner's Name _____ Address _____

State Registration/Documentation _____

Engine Model and Serial Number _____

Head Model and Serial Number _____

Stove Model Number and Serial Number _____

Spar Number _____ Rigging Kit Number _____

*Your Cape Dory is identified by a hull identification number (HIN) on the starboard corner of the transom. This identifies the number of the hull and supplies government officials with additional information concerning the builder and the year of manufacture. There is also a builder's plate with the hull number. In addition, there are serial numbers on your boat's engine (see the engine manufacturer's owner's manual) and on some of the accessory equipment which you may elect to have installed.

We recommend that you record these important numbers carefully and keep copies of them both at home and aboard (see "Owner's Record" form). These numbers and an accurate description of your property, in the event of theft, could be essential to their recovery.

Marking an inconspicuous place such as the inside of a locker, underside of a door or drawer, or the base of the mast with your initials, social security number or other unique "brand" may also aid in the prompt identification of your property, should the need to do so ever arise.

DEALER'S COMMISSIONING CHECKLIST

Model _____ Hull Number _____

Owner's Name and Address _____

Dealer _____

Date Sold _____ Date Launched _____

* Indicates further information and/or drawings elsewhere in manual

1.1	Date	Initials	Receiving Record
1.	_____	_____	* All items on receiving checklist received in good order. Dealer should notify factory within ten (10) days of receipt, of any shortages or damaged goods.

PRE-LAUNCH CHECKLIST

2.	_____	_____	Visually check underwater hull surface for any damage sustained during trucking or handling.
3.	_____	_____	Thru hulls all tight and clear of any foreign objects.
4.	_____	_____	* Seacocks and valves all closed. Hose clamps tight.
5.	_____	_____	* Check two propeller retaining nuts for tightness. Cotter pin in place and bent over (applies to 27, 28 and 30 only).

Record propeller information below:

Diameter _____ inches

Pitch _____ inches

Rotation _____ left or right hand

of Blades _____ 2 or 3 (optional)

On Cape Dory 25's it is sometimes easier to install outboard motor prior to launching. Check clearances and propeller angle.

6.	_____	_____	*Rudder swings freely side to side. (On CD-30's with worm drive steerers, wheel must be turned.)
7.	_____	_____	*Stuffing box packing adjusted (applies to 27, 28 and 30 only).

- 8. _____ *Bottom under cradle poppets or bulkheads sanded, primed and painted. (Fresh coat of bottom paint prior to launching, highly recommended.)
- 9. _____ *Bilge dry.
- 10. _____ *Bilge pump connections okay and handle on board.
- 11. _____ Check deck and hull for any chips in gel coat.

POST-LAUNCH CHECKLIST:

- 12. _____ Immediately after launching, check bilge for water. If water is present, check all thru hulls and stuffing box.
- 13. _____ Open seacocks or valves one at a time and check for leaks.
- 14. _____ *Check stuffing box. The propeller stuffing box should drip water slowly, approximately one drop every ten seconds while shaft is turning to insure that the bearing and packing gland are lubricated by water. The rudder shaft stuffing box may not weep at all except in rough conditions.
- 15. _____ *Check battery switch and electrical system operation.
- 16. _____ Check battery electrolyte and charge level.
- 17. _____ *Check head operation.
- 18. _____ *Check bilge pump operation.

ENGINE START-UP CHECKLIST: (applies to 27, 28, & 30 only)

The following checklist is not intended to replace the engine manufacturer’s manual. Refer to that manual before starting engine.

- 19. _____ Check engine and transmission oil level and condition.
- 20. _____ Check belt tension on all belt driven components.
- 21. _____ *Check that cooling water intake seacock is open.
- 22. _____ Check to see that all clamps on exhaust hose are tight (on Yanmar engines make sure that exhaust hose enters water lock at location marked “in”)
- 23. _____ On fresh water cooled engine check water level and antifreeze in the expansion tank.
- 24. _____ Check engine mount nuts for tightness.
- 25. _____ *Check transmission bolts for tightness.

26. _____ *Check shift and throttle cable connections.
27. _____ *While coupling is disconnected, check prop shaft alignment using feeler gauges - .002” gap between flanges maximum – Note: Alignment should be checked several times during the first season after the rig has been tensioned and the flexible mounts have taken a set.
28. _____ Check prop shaft set screws, and see that they are wired in place.
29. _____ Start engine according to the manufacturer’s recommendations. Failure to start may be due to air in the fuel lines. Refer to manual for bleeding instructions.
30. _____ Immediately after engine starts, check to see that water is coming out of the transom exhaust port.
31. _____ Check gauges and/or warning lights.
32. _____ Check entire system for water, oil, fuel, or exhaust leaks. Note: sealers and paints may burn off as engine heats up the first few times.
33. _____ *Check throttle and shift operation.
34. _____ *Recheck stuffing box.
35. _____ *Report any unusual noises or vibrations to the factory immediately. Do not continue to run engine if any are present.

RIGGING CHECKLIST:

36. _____ Check all fasteners on spars for tightness.
37. _____ *Reeve halyards.
38. _____ *Attach stays, shrouds, spreaders and topping lifts. Wire or seize end of spreaders to upper shrouds. Spreaders should angle slightly upwards and bisect the angle formed by uppers.
39. _____ Check all clevis pins and cotter pins for security. Tape all potential chafe points including spreader bases and ends.
40. _____ *Check wiring of combination deck and bow light. Be sure bulbs work prior to stepping the mast.
41. _____ Step mast and rigging.
42. _____ Check all rigging for length.

- 43. _____ Check all clevis and cotter pins for security. Be sure the locking nuts on the turnbuckles are secure. Tape all potential chafe points.
- 44. _____ *Tune rigging to proper tensions (including bobstay on 28 and 30).
- 45. _____ *Attach booms, sheets, blocks, oars, reefing lines toping lifts, etc.
- 46. _____ Wire bow and deck lights.

MISCELLANEOUS CHECKLIST:

- 47. _____ *Fill water tank(s) and check operation of all pumps and drains.
- 48. _____ Fill alcohol tank (27, 28 and 30). Check for leaks and test operation of stove. See manufacturer’s literature on all stoves.
- 49. _____ Water test ports and hatches.
- 50. _____ *Recheck all thru hulls, valves, seacocks, hose clamps, hoses, and stuffing boxes.
- 51. _____ *Bend on sails.
- 52. _____ *Interior appointments complete.
- 53. _____ Optional equipment installed and operational.
- 54. _____ Owner’s packet, ship’s papers, and ignition key given to owner.
- 55. _____ Checklist (warranty registration) ready for mailing to factory.

I CERTIFY THAT I HAVE READ AND UNDERSTAND THE CONDITIONS AS LISTED IN CAPE DORY YACHTS’ WRITTEN LIMITED WARRANTY.

Owner _____ Dealer _____

Date _____ WITHIN SEVEN DAYS OF LAUNCHING,

RETURN CHECKLIST TO:
 Cape Dory Yachts, Inc.
 160 Middleboro Avenue
 East Taunton, Mass. 02718

INTRODUCTION

The intent of this manual is to help the owner of a Cape Dory to understand and maintain his yacht. This manual should be used in conjunction with other publications to fully understand the demands and pleasures of sailing. Reading monthly periodicals such as SAIL, CRUISING WORLD, YACHTING, SAILING, etc. is recommended. Obviously, personal knowledge and skills are required to handle and maintain any boat successfully.

Cape Dory yachts are constructed in a facility located in East Taunton, Massachusetts. Our boats are assembled using modern methods, equipment, and materials obtained from the most reputable suppliers.

The basic Cape Dory hull design is a traditional one, which has proven itself over many years of use and thousands of miles of cruising. The long keel with attached rudder hull configuration combined with a generous but not overly broad beam provides stiffness and stability; it also provides protection for the rudder, propeller, and propeller shaft. With the advent of the CD-270, the Cape Dory line of quality built full keel sailboats has been expanded to include the world of centerboarders, providing the accessibility to shallow water cruising areas, which only this type of boat can offer. The CD-270 sail plan was designed primarily for cruising with a moderate aspect ratio main and a small head sail as standard equipment. This combination provides a family, or shorthanded sailors, the ability to easily control the boat and sail in comfort through most wind conditions. The moderate beam and displacement of the CD-270 provides an interior volume with generous accommodations and storage space.

Cape Dory continually seeks to produce the highest quality yacht possible. Product development is an ongoing process by which features are added or improved upon. For this reason, some variations may appear in your boat from that which appear in this manual. Each modification is made with the intent of providing you with the best possible CD-270 we can build.

To protect your investment and to insure the enjoyment of your Cape Dory, we recommend that you read this manual carefully and complete the enclosed Commissioning Checklist with your dealer. This provides you and the Cape Dory dealer with guidelines to inspect your boat and to verify that all equipment on board is correct and in good working order. The checklist is for your protection; insist that it be completed. One copy must be returned to Cape Dory Yachts as a warranty registration. Once this registration process has been satisfactorily completed, your dealer can, if necessary, file warranty claims for parts or service. He cannot do so unless the checklists are completed and returned. At this point you become a member of the Cape Dory Owners' Association.

The Cape Dory Owners' Association

The Cape Dory Owners' Association was formed as the company grew from its original beginnings in 1964 as a sailing dory builder. The earliest Cape Dory owners would gather for regattas, races, and picnics in summer and during the frostbite season in the winter months. Later, as the Typhoon spread in popularity, more and more activities began taking place involving that class. With the advent of the Cape Dory 25, other Cape Dory owners readily welcomed the newcomers.

Today, the Cape Dory Owners' Association is national in scope, and activities are increasing in number rapidly. Several Typhoon fleets are actively established and most Cape Dory owners find the Association an excellent means of communication. The Association periodically publishes a newsletter which contains interesting, as well as helpful, information.

[Addendum:

The Cape Dory Owners Association sponsored by Cape Dory disappeared with the demise of the company but there are several independent owners associations from which to choose:

Cape Dory Sailboat Owners Association (CDSOA, Inc.): <http://www.capedory.org/>

This is a national association of Cape Dory sailboat owners headquartered in Maryland. It has members located nationwide, as well as abroad, and with several regional fleets they hold multiple on-the-water rendezvous events annually for both Cape Dory, Intrepid and Robinhood sailboat and powerboat owners in each region.

California Cape Dory Owners Association: <http://www.toolworks.com/capedory/>

This owners group is based in California and most of its activities take place in the San Francisco Bay area.

Lake Michigan Cape Dory Owners Association: <http://www.lmcdoa.org/>

This owners group centers its activities around Lake Michigan.

End of addendum.]

I. THE CAPE DORY OWNER

Owning a Cape Dory 270 provides one with the means to enjoy life's myriad of experiences from offshore sailing to coastal "gunkholing" all at one's own pace. Along with the great pleasure that sailing offers are the responsibilities of life and property associated with it.

This manual, along with the equipment manuals provided in the ship's papers envelope, should give you all the information necessary to maintain the boat properly. If further explanation or advice is needed, consult your Cape Dory Dealer.

Seek the services of qualified mechanics or equipment representatives when major work must be done to your yacht or when seeking advice on matters of equipment maintenance and repair.

When using your yacht, the safety of all on board is essential to the enjoyment that can be experienced on the water.

Careful guidelines have been established by the U. S. Coast Guard, the American Boat and Yacht Council, and others to insure the safety of those on board. The owner is responsible for the use and maintenance of their Cape Dory 270 as prescribed by these agencies.

Following recommended guidelines, good commonsense, and a realistic evaluation of your own abilities and those of your crew will provide the enjoyment and pleasant memories you expect in owning a Cape Dory yacht.

II. SAFETY

Federal regulations REQUIRE certain safety equipment to be onboard your boat (personal and throwable floatation devices, fire extinguishers, horn, whistle, etc.). Know what equipment is required and have it aboard and properly stowed before you cast off for the first time.

In addition to the equipment requirements outlined here, the U. S. Coast Guard can provide additional information and answer your questions. It is highly recommended that, although not required, certain additional items be kept aboard. This list is not complete, you should have all USCG required gear.

1. An anchor of appropriate size and design and rode of good quality, appropriate size and length.
2. First-aid kit.
3. Compass.
4. Paddle.
5. Flashlight.

6. Up-to-date charts of the waters to be sailed.

7. Flares.

Fire extinguishers are not standard equipment on your Cape Dory; they are to be provided by you, the owner. Fire aboard any boat is a real serious hazard. It is important to take adequate precautions against fire and to be well prepared to extinguish one quickly and thoroughly should it occur. For this reason, U.S. Coast Guard approved fire extinguishers of the appropriate type and size (check U.S.C.G. regulations) should be installed immediately.

The permanent location of fire extinguishers where they are easily accessible (near areas where fires most likely are to occur - engine, fuel tanks, and galley) is important. They should not be located where fire may prevent their use. At least one extinguisher in a cockpit locker (reachable from outside the cabin) and one extinguisher installed below is a minimum.

CHARTS

There is no substitute for complete and up-to-date charts.

The Coast Guard is constantly making improvements on the aids to navigation which change buoy locations, numbers, configurations, etc. These changes are reported in the respective Coast Guard District's Local Notice to Mariners, and are on display at all NOAA Chart Distributors. Before embarking on any trip outside your home port, make certain that you have the latest editions of the chart, and that they are fully corrected.

FUELING

Appropriate safety precautions are important before, during and after fueling. Before fueling the first time, be familiar with the instructions provided by the engine manufacturer.

1. Fuel docks should be approached at REASONABLE speed without wake. Observe posted speed limits and instructions. Be considerate of others using the docks, and watch for a dockmaster or hand who may give you instructions. Maintain control of your boat at all times and have your dock lines ready for use before you approach in the event that these are unavailable at the dock.
2. Use bow, stern and spring lines to properly secure your boat.
3. Close and secure all hatches and ports.
4. FORBID SMOKING while taking on fuel on or near fuel docks. Completely extinguish all smoking materials well in advance of approaching the docks; do not recommence until you are well clear of it after fueling and conditions aboard are safe to do so.

5. Extinguish any other open flames aboard and see that all equipment (e.g., engine, stove, cabin heater, radios, and lights - both lanterns and electrical lights, etc.) which may generate heat or sparks of any kind turned OFF...Turn off all switches for branch circuits so that there are no live electrical circuits. MAIN SWITCH should also be turned off AFTER engine is stopped (to avoid alternator damage).
6. If possible, crew members not involved in fueling should leave the boat.
7. An adequate fire extinguisher (USCG approved for Class B fires) should be readily available in case of emergency.
8. Remove fuel fitting. Be certain that you are putting fuel in the fuel tank. Note the approximate amount required to fill the tank by either looking at the fuel level gauge if one is in the tank.
9. Be certain (double check) that you are taking on the appropriate fuel, diesel not gasoline. Errors of this type do occur and will result in serious engine damage if not immediately detected and corrected.
10. Sometimes if you are in an unfamiliar area you may want to first take a sample of the fuel you plan to pump on board for a visual and smell check to insure that it is diesel and not gasoline.
11. Maintain contact between the nozzle of the fuel hose and the fill pipe rim to prevent generation of static electricity sparks.
12. Fill slowly to about 95% of capacity; do NOT overfill. (Allowance must be made for thermal expansion of fuel without overflow.)
13. Replace and secure fill fitting after fueling. Carefully clean any spillage. Check fuel tank vents at stern for overflow. Check below decks and in the bilge for fumes or leakage. If fumes or leakage are present, adequately ventilate and clean areas completely BEFORE PROCEEDING.
14. Open all ports and hatches fully for ventilation.
15. Do not fuel during electrical storms; avoid fueling at night or in rough water, except in emergencies when extreme caution must be exercised.
16. Note that diesel fuel is flammable; handle it accordingly in a cautious manner.
17. Those Cape Dory owners with outboard engines should note that perhaps the safest fueling practice, when possible, is to remove the tank(s) from the boat before filling.

DOCKING AND ANCHORING

When docking or anchoring, several things should be mentioned for your's and the boat's safety. Become familiar with the characteristics of your steering and engine control systems. You will notice that the boat behaves very differently in forward than in reverse and that backing down must be done slowly with great care. Approach the dock or anchorage slowly with gear stowed and the least amount of movement about the boat as possible. In the case of docking, boat fenders and dock lines should be readied and if need be, assistance requested from dockside. When mooring, have the mooring hook ready and a clear fore deck for secure footing. When docking, tie off your lines properly. Do not use the genoa winch or cleat for dead ending a dock line and use springlines. When tying off to a piling or other fixed object, allow enough slack to compensate for the rise and fall of the tide •

Anchoring can be a very involved process. Tide changes, crosswinds, tight quarters, rocks, and varying bottom conditions are some of the things you should be aware of when selecting a suitable mooring or anchorage. Get advice and study up on the many variations of anchoring. Most important to safety though is to make sure the bitter end of the anchor rode is securely fastened and that the line can run free without entangling itself, something, or someone. When leaving the boat, make sure that the DC panel is off, unless set to power an electric bilge pump. All ports and hatches should be dogged down tight or locked ; sails properly stowed or tied off, all chafing gear set in place, and the centerboard in the up position.

III.

CAPE DORY YACHTS, INC.

**160 Middleboro Avenue
East Taunton, Massachusetts 02718
(617) 823-67876**

Limited Warranty

1. Cape Dory Yachts, Inc. (Cape Dory) warrants all yachts and parts manufactured by it to be free from defects in material and workmanship under normal use and service for a period of twelve (12) months from the date of delivery to the original purchaser. This Limited Warranty is extended to the original purchaser of the yacht, and is not extended to any subsequent purchaser.
2. This Limited Warranty applies only to those components of the yacht manufactured or built by Cape Dory. It specifically does not extend to paints, gel coats, anodized finishes and other surface coatings, wooden parts which may split, crack or check (due to climatic factors over which Cape Dory has no control) and all accessories, and installed equipment not manufactured by Cape Dory, including without limitation engines, engine parts, instruments and controls, sails, pumps, batteries, winches, wheel steering hardware, upholstery, turn buckles and plumbing equipment. Any warranty made by the manufacturer of such items will, if possible, be passed on to the purchaser. This Limited Warranty does not extend to yachts used for commercial purposes or those which have been altered or subjected to negligence or misuse.
3. To validate this Limited Warranty, the "Dealer's Commissioning Checklist" must be mailed to Cape Dory, 160 Middleboro Avenue, East Taunton, Massachusetts 02718 as soon as possible after the commissioning date. In order to obtain performance of any warranty obligation, the owner must report within fifteen days of its discovery any claim in respect of defects in material or workmanship to an authorized Cape Dory dealer. Cape Dory or its authorized representative may make an inspection within a reasonable length of time after receipt of notice of a claim. When a warranty claim is valid, Cape Dory or its authorized representative will repair or replace the defective component part free of charge. Cape Dory may require a yacht or any part thereof to be returned to the factory, its dealer or representative for examination, transportation charges prepaid. Cape Dory neither assumes nor authorizes any person to assume for it any liability or expense in the replacing of parts or correction of defects in a yacht within the warranty period, except when such expense is authorized in advance and in writing by Cape Dory.
4. ***Exclusion of Warranties: This Limited Warranty is in lieu of all other express warranties, and shall expire twelve months from the date of delivery to the original purchaser. Any implied warranty, including the warranty of merchantability and fitness for a particular purpose, is limited to the duration of this limited warranty.***
5. Cape Dory does not under any circumstances assume responsibility for any consequential damages incurred including without limitation expenses for transportation and travel, telephone, lodging, loss or damage to personal property or loss of revenue.
6. Cape Dory reserves the right to improve its products through changes in design and material without incurring any obligations to incorporate such changes in units already completed or in the hands of dealers or purchasers.
7. Some states do not allow limitations on how long an implied warranty lasts or the exclusion of incidental or consequential damages, so the above limitations or exclusions may not apply to you. This warranty gives you specific legal rights and you may also have other rights which vary from state to state.

WARRANTY NOTIFICATION PROCEDURES

Cape Dory Yachts is very proud of its "track record" of minimum warranty problems. After commissioning, you as an owner should not expect problems to develop. However, should you need assistance, there is only one very important thing to do...CONTACT YOUR CAPE DORY DEALER.

Your Cape Dory dealer is a knowledgeable professional who is familiar with your boat and capable of answering most of the questions which you may have. He will communicate any problems or inquiries which you may have directly to Cape Dory so that we can both work together toward an expeditious and satisfactory solution.

YOUR DEALER IS NOT, HOWEVER, AUTHORIZED BY CAPE DORY TO CONSENT TO REPAIRS OR THE REPLACEMENT OF PARTS WITHOUT THE EXPRESS WRITTEN APPROVAL OF CAPE DORY.

Cape Dory Yachts, like most other sailboat manufacturers, offers a written limited warranty.

To you as an owner, we at Cape Dory Yachts pledge to provide you with a product that is as defect-free as possible. Our goal will continue to be one of standing behind our products and one of continual improvement.

IV. CAPE DORY 270 DESIGN

The Cape Dory 270 represents a departure from a line of boats which up to present has been exclusively deep draft with full keel, attached rudder, moderate beam, and predominately designed by Carl Alberg.

Cape Dory Yachts commissioned Dieter Empacher to design a 27' full keel centerboard/sloop as a cruiser that would reflect traditional appearance and offer the performance of a modern hull shape. By keeping the hull draft down to three feet and designing the displacement into long waterlines, the wetted surface-to-displacement ratio is such that it guarantees good light air performance.

As the boat heels and reaches full waterline length, it becomes a good heavy weather performer. With a four-foot centerboard extension below the keel, the yacht has excellent upwind ability. The hull entry is fairly fine to aid in upwind performance with a slight flare added to the topsides forward to provide a fairly large foredeck working area and recessed anchor well.

Through careful design and engineering, Cape Dory has produced a centerboard system that is easy to use and maintain.

The CD-270 represents the combined efforts of Dieter Empacher and Cape Dory Yachts to produce a yacht that is a pleasure to own. Cape Dory reserves the right to refine and upgrade the CD-270 in an endeavor to produce the finest quality centerboard yacht of its size on the market today.

V. CONSTRUCTION

HULL

The Cape Dory 270 hull is molded in one piece using alternating layers of hand layed fiberglass rovings and mats bonded with lightweight polyester resin.

Into the open hull mold, white gel coat is sprayed over the entire surface to an approximate thickness of 22 mil. A dark-colored backing coat is then applied on top of this for air detection during subsequent layup.

The first layer of glass is 1.5 oz/sq. foot mat.

After this successive layers of 2410 Promat (24 oz/sq. yard non-woven bidirectional roving with a 1.0 oz/square feet mat backing) are hand laminated into the hull mold. The final result is a strong quality lamination with proper glass to resin ratio.

The centerboard trunk and pin tubes are molded integrally with the hull and are built up with the same layers of 2410 that the rest of the hull bottom laminate is comprised of.

The hull topside laminate is molded inward on to a mold, forming the internal flange which makes up the hull portion of the hull/deck joint. (see drawing detail)

DECK AND HEADLINER

The deck is also laminated by hand in an one piece mold to produce the shiny white and molded in non-skid surfaces.

After the gel coat has been applied to the mold, a backing of 1-1/2 oz. mat is layed over it. In addition, along the vertical sides of the deck house a 2.0 oz. promoted mat is used. This layer of promoted mat prevents roving print through into the gelcoat from latter layers of reinforcing.

After the promoted mat is applied, a layer of 1-1/2 oz. mat is applied to all horizontal surfaces into which 3/8" thick end grain balsa panels are placed and pressed.

At this point, plywood coring is also located and placed for eventual through bolting of deck hardware. Finally, 2 layers of 1808 Promat are applied. Aluminum plates, which form backups for other deck hardware, are glassed in place at this point. Unidirectional roving is added to reinforce areas subject to stress cracking.

The headliner is molded on a textured female mold. A layer of antique white gelcoat is sprayed over the mold. This gel coat after curing is reinforced with 2 layers of 1.5 oz mat and a layer of 18 oz woven

roving. Unidirectional roving is again used on this part in areas subject to stress cracking.

Bulkhead bosses are filled with a microsphere and resin mixture for further stiffening.

The deck and headliner are pressed together in a jig with a resin and microsphere mixture used as a bonding and compression matrix in areas of high loading.

After the microsphere mix has cured, the combined unit is pulled from the mold and delivered to the deck hardware department for attachment of wood parts and hardware.

BALLAST

The lead ballast is cast and mounted inside the keel cavity of the hull. The ballast set is composed of three individually cast pieces each one of which is checked against an optimum weight and matched with others to produce the correct total weight.

Each side piece straddles the section of fiberglass CD pin tubing extending from the trunk to the hull on its side, and the forward piece butts up to the forward end of the side pieces. Each piece is checked for proper location horizontally and vertically before it is set in place.

The ballast is bedded in a mixture of special low shrink resin and microspheres. This bedding acts as a shock loading barrier between the keel and the ballast as well as an adhesive to bond the ballast in place and seal the centerboard tubes.

The ballast is leveled and then covered with several layers of glass cloth running up on the hull on each side. Upon curing the bilge, ballast, and area below the cabin floor is painted with a beige gel coat for ease of cleaning.

RUDDER

The rudder assembly is comprised of two molded fiberglass half shells bonded together with the rudder shaft and gudgeon insert glassed in place.

A solution of microsphere and resin is poured into the assembled half molds and allowed to cure to full hardness.

Once the rudder is removed from the molds, it is glassed and faired along its edges.

The bronze gudgeon casting is imbedded in the bottom of the rudder to accept the bronze pintle casting and stainless steel pin which is attached to the keel. The pintle is set in a polysulfide bedding compound and fastened onto the hull with bronze rods that pass through

the solid heel portion of the keel. The entire casting is then faired with polyester putty and glassed into the keel.

JOINER UNITS AND BULKHEADS

The joiner units in the CD-270 are pre-built, as if they were cabinet units, in the wood shop. Building these parts this way allows for more precise fits, better fastening, and in general a more durable assembly.

The forward unit is comprised of the head compartment and vee berth. It is placed in the hull with a jig which determines the proper alignment. It is then glassed in place with 3 layers of bi-directional wov-mat tape.

The edges of the bulkhead where they land on the hull are fitted with precut strips of Airex foam to provide ease in tabbing and to avoid building a hard spot into the hull which would be noticeable from the outside.

The galley unit is set in place with another alignment jig. It is glassed in place similar to the forward unit.

Once these two units have been glassed in place and the floor grid support is firmly bonded to the hull, the main cabin sole is fastened in place, port and starboard settees finished off, quarterberth installed, and mechanical installations begin.

VI. INTERIOR

The interior has been designed to accommodate 6 people for sleeping. The vee berth is provided with a filler piece stored in the large bin below the vee berth cushions. Two adults can sleep comfortably in this area.

The port settee converts to a 44" wide double when pulled out 10" to its extended position. A dowel has been provided for support at the end near the companionway. A separate 4" x 10" x 78" cushions is stored behind the port backrest. On models after hull #009, the backrest forms the berth extension.

Both port and starboard backrests swing up to a fixed position and are held in place on the forward or aft bulkheads by a sliding bolt located at the end of the backrest.

There are storage bins, drawers, and lockers features in all areas of the boat as well as drawers and lockers allowing an even distribution of gear located for handy accessibility.

The recess of the quarterberth and the footwell on the starboard side settee berth can oft times provide handy storage for a variety of gear when not in use such as sleeping bags, blankets, or pillows.

The two doors fitted in the passageway through the head area are locked in place, in the closed position, with sliding bolts mortised into the

upper frame of the door. The bifold head door is held in place, when open, by a friction catch mounted to the vanity unit front.

Ports and hatches are provided to allow an even cross flow of air throughout the boat under many varying climatic conditions. One may keep the head port slightly ajar nearly all the time for an exchange of air from the dorade. Be aware of ports that are open, and by how much, to avoid unnecessary shipping of water and potential injury from their projection into the living space.

Ventilation is key to a habitable interior and a good flow of air makes a world of difference.

VII. DIESEL AUXILIARY

You have received a copy of the engine owner's manual with your boat which should be read thoroughly before operating the engine. Specific details and instructions are listed which should be clearly understood by the owner.

Routine maintenance as listed by the engine manufacture is key to engine longevity.

The engine bed is a molded fiberglass unit, bonded to the hull with several layers of fiberglass. It is built so as to spread the load of the engine in all conditions over a large section of hull. At the same time, it provides a separate sump area for the collection of oil which may drip from the engine.

The engine bolts to the fiberglass engine bed on vibration dampening motor mounts which also serve as points of alignment for the engine and propeller shaft.

Access to the engine may be gained from several areas each of which may serve as a combined or singular access to a specific part.

The front of the engine may be serviced from behind the companionway ladder with the front engine cover removed. To gain access to equipment on the starboard forward end of the engine, open the trap below the galley sink. Access to the aft end of the engine and propeller shaft must be done through the access trap under the cockpit in the starboard sail locker. The port side of the engine may be accessed through a removable panel in the quarterberth cockpit support bulkhead.

To remove the engine from the boat requires removal of the starter, and alternator and the disconnecting of the propeller shaft from the gearbox. Once this has been accomplished and all hoses have been disconnected; the engine may be hauled out the companionway using a properly rated hoist.

The exhaust is a wet system consisting of an engine water injected elbow, a waterlock muffler and heavily reinforced rubber hose. The main advantage of this type of exhaust system is that it allows the cooling

water to cool the exhaust gases as they leave the engine. This system produces a quieter sound and reduces temperatures in the engine room minimizing the risk of burns and reducing the fire hazard.

There are several maintenance features not covered in the operators manual which should be mentioned here.

CORROSION

Internal and external engine corrosion can be a slow unnoticeable process until it is too late. The most common cause of this is from non or misuse of the engine.

Avoid running the engine whenever possible for periods less than 15 minutes in duration in order for the engine to generate enough heat to expel any internal condensation build up. This is especially critical in cold weather when condensation is greater. Short duration usage will cause internal corrosion resulting in damaged rings and sticky valves. Running the engine occasionally at full throttle for about 5 minutes will clean out moisture and carbon build up in the system.

When the engine is not intended to be used for a long period or for lay up through the winter, introduce oil into the air intake and onto the cylinders. This will effectively seal the inside parts against the environment.

Externally if paint chips off or if some corrosion develops, use bronze wool to clean the surface and spray the area with engine paint..

The normal cruising speed of the boat under power is between 5 and 5-1/2 knots and full throttle will produce a speed of approximately 6 knots. Excessive hard driving of the engine will shorten its usable life.

The shift and throttle cables are black plastic encased wires which route through the sail locker to the respective control levers. No initial adjustment should be necessary after you receive your boat from the factory.

Readjust the shift cable travel at least once a year making sure that the transmission gear fully engages in forward and reverse gears.

Should a control cable need to be replaced, it must be replaced with the same length and style of cable.

Use care when using the throttle controls. On tiller steered boats, the controls are set up to also shut the engine down by pulling the throttle all the way back past idle. Become familiar with this characteristic so that the engine is not shut down inadvertently.

Do not force the shift lever to the ends of its travel. If this is done repeatedly, the cable will break.

ALIGNMENT

The alignment of your engine is one of the most critical adjustments made on the boat and should only be carried out by experienced service personnel.

A poorly aligned engine will cause excessive vibration, worn stern bearing, leaking throughout the stern tube/stuffing box assembly as well as possible damage to mechanical parts within the engine and generator box.

Cape Dory ships all boats with the engine and propshaft couplings disconnected and it is part of the responsibility of the dealer during the commissioning process to properly align the engine.

After stepping the spar and tensioning the rigging, the engine and propshaft may be aligned.

Generally, the procedure for aligning the engine and shaft is as follows:

Using a feeler gauge, check the gap between the engine and shaft coupling flanges. If the gap exceeds at any point .002", then the engine must be adjusted using the motor mounts as levelers so that the flanges meet evenly along the entire mating surfaces.

Holding the propshaft stationary, rotate the engine coupling 360 degrees to see that the gap remains constant. If not, adjustments must continue.

Check the alignment again a week or two after the initial alignment and make further corrections if necessary.

Never align an engine out of water.

It should be noted that sometimes vibration can occur when the balance of a propeller does not match that of the shaft coupling assembly. In this case, merely rotating the propeller shaft coupling to another setting on the engine coupling should reduce or eliminate it.

The stuffing box assembly connects to the fiberglass stern bearing tube with a 4-1/2" long section of 1-1/2" ID hose double clamped at both ends. The stuffing box is packed with lubricated flax stuffing material which when compressed by tightening down on the stuffing box nut forms a self-lubricating water seal on the shaft through which an adjusted amount of water is allowed to flow.

Water should drip from the end of the stuffing box at the rate of about two drops per minute. Once this rate is established, lock the pack nut in place with the smaller check nut and frequently check the set up after that.

To replace the packing, disassemble the nuts from the stuffing box and clean out the old packing material. Wrap a 10-1/2" length of packing on

the shaft between the packing nut and the stuffing box and slide the nut back in place with the new packing. This procedure should only be attempted with the boat out of water. Once launched, realign the shaft, run the engine, checking the water flow again making any necessary adjustments as described before.

A two bladed 13 x 11 RH bronze propeller is installed as standard with the Westerbeke 13 marine diesel.

To remove the propeller, a special service tool must be used in order not to distort the propeller or bend the shaft. A propeller puller provides even force around the propeller when centered properly on the shaft.

Remove the cotter pin, zinc and lock nut. A light tap with a block of wood or rubber headed mallet should dislodge a stuck propeller when used in conjunction with a propeller puller.

Before refitting the propeller, check the assembly parts for corrosion or wear and replace if necessary.

The propeller shaft is made from solid bronze 1" diameter stock. Its straightness conforms to the standards set up by ABYC as a guideline for shafting. The taper conforms to SAE standards for propeller shafts and is fitted with a 1/4" keyway, 2" long.

The shaft is supported by a cutless bearing within a fiberglass stern tube in the aperture and a solid half coupling at the engine.

When painting the bottom of the boat, avoid painting the cutless bearing as a flow of water is absolutely necessary around the shaft for good lubrication at the cutless and the stuffing box. If these dry out, the life of each is shortened and the shaft will overheat possibly causing distortion which cannot be repaired.

By shifting the engine into reverse with the engine off and under sail, you will prevent the propeller from "freewheeling" in neutral. This "freewheeling" can cause excessive gear wear, overheating of the gear box and noise if allowed to do so for long periods of time.

By locking the propeller vertically behind the forward end of the aperture, you can decrease drag and protect your propeller from fouling. Align the propeller with the keel and mark reference points on the coupling and engine for a quick visual check for alignment.

FUEL SYSTEMS

The fuel system incorporates a 5052 aluminum alloy fuel tank and a combination of flexible fuel lines and reinforced rubber hose. The fuel fill deck plate is located on the starboard side deck adjacent to the forward lower chainplate. It connects to the fuel tank via an 1-1/2" ID U.S.C.G. rated fuel hose. Flexible fuel lines have been chosen as they are very easily repaired in the field should a leak develop. Copper fuel lines require special tools to repair which may not be available at

sea. Every installation includes a fuel filter and a fuel filter/water separator for that extra measure of safety.

In order to run, a diesel's only requirement is clean, waterfree, airfree fuel and combustion oxygen. There are no spark plugs or ignition requirements. 95% of all diesel engine problems result from fuel problems. The engine manual that comes with the engine describes the bleeding procedures and every owner should know how to do this. The fuel feed line must be 100% air tight or it will suck in air which eventually will reach the high pressure pump and cause the engine not to start until this air is expelled. All engines are test run at the plant and are fully bled, however, air may be introduced in trucking or launching and must be bled out once the boat is launched. The fuel system consists of rubber hoses secured with hose clamps and threaded fittings made tight with pipe dope tape or sealer. The complete fuel line from the pick-up tube in the tank to the fuel pump in the engine must be tight or air will be introduced.

All CDY engine installations incorporate two fuel filters which also must be air tight. Any time the fuel system is opened up, as when changing a fuel filter, air will be introduced into the system which must be bled out.

Other problems that can occur are caused by dirty or water laden fuel. Water is especially harmful in that its presence in the delicate passages of the high pressure pump will cause rust which may ruin the very costly fuel injection system. The best way to avoid water in the fuel is to keep the fuel tank nearly full at all times. This reduces the air space in the tank, which cuts down condensation. The water separator should be periodically checked and drained when necessary.

Diesel fuel stabilizer also works, is highly recommended, and can be obtained from your local fuel dealer.

When filling the fuel tank, care must be taken not to overfill it. This will result in excess fuel being expelled out the vent hose and into the ocean which is illegal. Care must also be taken to see that the fuel fill cap is replaced securely so that no water will leak into the tank.

Fuel drawn from a cool underground tank will expand when placed in the warmer ship's fuel tank. Therefore, the tank should only be filled to 95% of capacity to allow for expansion.

Diesel fuel, while less volatile than gasoline, is still combustible and extreme care should be taken while fueling or working on the fuel system. Never allow a mechanic to use ether as a starting aid. Ether can cause over pressurizing of the small cylinder on an auxiliary diesel.

The aluminum fuel tank is located under the starboard settee. All fittings may be readily accessed through a cutout below the cushion. A 5/8" ID rubber hose vents to the starboard side of the transom. The vent fitting incorporates a stainless steel mesh screen insert.

Two 1/4" fuel lines run between the tank and the engine. One provides fuel to the engine and the other returns unused fuel from the engine back to the tank.

The engine cooling and exhaust systems combine to maintain even engine running temperatures by absorbing and expelling the heat that builds up in an engine.

The engine manual illustrates these systems in more detail, however, briefly they can be described as follows:

The sea water pump on the engine is driven by the crankshaft V-belt. It draws in sea water through a Spartan strainer thru hull fitting in a 3/4" seacock. On boats after #006, this has been changed to a 1" seacock with 7/8" hose adapter.

The cooling sea water passes through the heat exchanger on the engine drawing heat from the fresh water cooling system which then cools down the engine. The then heated sea water is expelled into the exhaust line where it mixes with and cools the exhaust gases down before being blown out the exhaust port in the transom.

Immediately after starting the engine, check to see that water is being expelled from the exhaust port in the transom.

If it isn't, not only will the engine block overheat but the exhaust system will overheat as well. If the engine is started with the seacock closed or water obstructed in another way, damage to the rubber impeller will result. A spare impeller should be carried aboard at all times and is easily changed. The routing of the exhaust hose should not be changed or problems may develop. For winterizing the exhaust system, a drain plug is fitted to the exhaust muffler allowing it to be drained.

VIII. ELECTRICAL SYSTEM

12 VOLT DC SYSTEM

The Cape Dory 270 standard electrical system is powered by a 12 volt 75 amp hour battery located in a battery compartment below the quarterberth. It is negatively grounded to an external ground plate located below the cabin sole trap inboard of the galley.

All wiring is plastic coated stranded copper wire, color coded and numbered for ease of identification. Connections are made with crimp-on butt connectors or terminal ends and sealed with silicone grease to prevent corrosion from moisture.

The standard battery is encased in a high impact, corrosion resistant case. It is important that a full charge be maintained at all times.

BATTERY VOLTAGE

The level of charge of the battery or batteries may be checked with the VOLT METER located in the center of the D.C. POWER PANEL. The level of charge of the battery, alternator output, state of the voltage regulator and power draw to services can all be checked with the use of the DC voltmeter. A voltmeter gauge is located on the engine instrument panel. Your voltmeter will indicate differently, depending when the readings are taken. Here are a few simple guidelines. Fully charged batteries that are in a static state should read between 12.3 - 12.6 volts on the numerical scale, and just barely be touching the high end of the yellow band on the colored dial of a gauge. (The term static means that the battery hasn't been charged or discharged for at least two hours.) If the pointer is in the yellow or red low band on a gauge, or reads between 11 - 11.5 volts on a voltmeter, then the battery is about half discharged and should be charged to insure its usefulness. If the engine is started, and the needle does not move up, this would indicate that no charge is being delivered to the battery.

When the battery is being charged, the pointer should be between 12.6 - 13 volts, which is approximately the center of the green band on gauge types. The pointer may move up to about the 13.7 volt range (the high end of the green band) toward the end of the charge cycle, at which time the pointer drops back to the 12.6 -13 volt range, as voltage regulation controls this function. If the battery voltage reaches 15 volts (which is the high red band on the gauge) this indicates that the battery is being overcharge~ and will damage the battery if left unchecked.

When the battery is being discharged (having electrical loads placed upon it) and no charging current applied, it is normal for the pointer to indicate between 11.4 - 12.6 volts, or be in the yellow band.

A FINAL WORD - The above guidelines provided are merely to help you to establish what is normal - the usefulness of the meter will depend on your own routine observations which will spot trouble when it occurs.

The BATTERY TEST SWITCH adjacent to the meter is used to directly connect the meter to the individual battery(s). The condition may then be read directly from the meter. The BATTERY SELECTOR SWITCH must NOT be in the ALL position and the engine should NOT BE RUNNING or false readings will result.

The battery(s) should be inspected and serviced at least once a month, more frequently when under heavy use. The terminals should be free from corrosion and tight on the battery posts and the electrolyte kept at the proper level by topping up with distilled water.

CAUTION: Avoid spilling battery electrolyte into the bilge and avoid getting any salt water in the battery. If this should occur, ventilate extremely well since poisonous gas will be given off. Avoid contact with eyes or skin using proper protection at all times.

If battery fluid comes in contact with any surface, wash thoroughly with clean, fresh water immediately.

The DC Electrical panel incorporates a Battery Select Switch and six DC circuit breakers.

The Battery Select Switch provides a means of shutting off the main DC power from the battery to the panel and engine. Or if two batteries have been installed it can be used to couple the voltage of each battery together to serve a particular task, usually engine starting.

CAUTION: DO NOT TURN BATTERY SELECTOR SWITCH TO OFF WHILE ENGINE IS RUNNING. SERIOUS DAMAGE TO THE ALTERNATOR WILL RESULT.

A red PILOT light is provided on the panel. This light is illuminated whenever the batteries are connected to the system and provides you with an additional reminder that the batteries are on and also provides enough light to read the switch panel labels at night. The pilot light draws very little current and will not run the batteries down even when left on for long periods of time.

There are several individual circuits provided on the D.C. POWER PANEL. Each circuit is activated by a toggle switch and protected by a circuit breaker. Before adding additional electrical equipment, check the required rating of the circuit breaker. Also be certain the number and size of the battery(s) is sufficient for the added loads.

A tripped circuit breaker is indicated by a raised white button. The breaker is reset by first turning the toggle switch off and then depressing the white button. Before attempting to reset a tripped breaker, an effort should be made to find the cause of the overload, the most common being a short circuit in one of the fixtures or wires, or trying to operate too many devices on one circuit.

A.C. 110 VOLT SYSTEM (OPTIONAL)

The A.C. system operates on 115 volt, 60 cycle current. Power is supplied from a 30 amp shore service by connecting the shore power cord to the receptacle in the cockpit well. Make sure the main circuit breaker on the A.C. POWER PANEL is in the off position when connecting the shore power cord.

IMMEDIATELY after connecting the shore power cable, check the 110 pilot light. If it is on and the main breaker off, this indicates a live circuit from the shore power receptacle. Next check the reverse polarity indicator light. -If it is on, disconnect the shore power cable IMMEDIATELY and determine the source of the problem as serious electrical shock hazards may exist to persons on board or alongside your yacht, even if the main circuit breaker is off. The ship's wiring has been thoroughly checked and is of the proper polarity when it leaves the factory. If the system has not been altered, the reverse polarity condition is in the shore side system and should be brought to the attention of the system operator. If the reverse polarity light does not come on, the system is safe to operate. Turn on the MAIN CIRCUIT BREAKER at the top of the panel and then select whichever branch circuit is needed.

CAUTION: Before turning on the hot water heater insure that the tank is full of water. Permanent damage will result from operating the heater with an empty or partially full tank. To check that it is full, simply open the hot water tap on the pressure water system and watch for continuous water flow.

On each Cape Dory that has been fitted out with a factory installed 110 volt AC system we have included or added a #8 green coated copper wire as a ground. This wire is led from the common AC ground to the engine and is in turn tied into the boat's ground system.

This ground cable is a safety feature installed to avoid serious electrical shock hazards should a connection to a faulty dockside power source be made.

Under no circumstances should this cable be disconnected irrespective of claims that a certain amount of electrolysis could be created by the addition of this wire.

BONDING SYSTEM

All thru hull sand seacocks below the waterline, including the stern tube, are connected to one another, to the engine block and to the external ground plate with a continuous loop of #8 copper wire. This is done to minimize the effects of electrolysis should one fitting become "hot" for any reason. Generally, a fiberglass hull is considered to be non-conducting and as such the chance of stray electrical currents forming is minimal. (Bonding system is standard on all diesel equipped Cape Dorys.)

As more and more electrical equipment is added to a boat, it becomes increasingly important to be alert TO THE THREAT OF ELECTROLYSIS. We recognize that there are various types of instrumentation available to further monitor strong currents and any potential difference between ground and the thru hulls. These instruments can all be added to the supplied ground wire system.

LIGHTNING GROUND SYSTEM

Your Cape Dory is equipped with a lightning ground system installed in accordance with the American Boating and Yacht Council (A.B.Y.C.) specifications. Every shroud and stay is connected to an external ground plate by a #8 a.w.g. stranded copper wire. Other equipment requiring bonding include the engine, fuel tank, mast step and fuel fill cap. Within practical working restraints, the wires are lead directly to the ground plate.

While no one can predict how lightning will react when it hits a spar, we know from actual experience that this system offers added protection.

During a lightning storm refrain from touching any metal objects such as shrouds, mast, stanchions, pulpit, etc., as these may attract lightning.

Do not paint the external ground plate with bottom paint as this prevents the plate from grounding out with the seawater.

Periodically inspect the connections in the bilge to see that they are tight and clean and free from corrosion.

ELECTROLYSIS AND CORROSION

Underwater corrosion results from an electrical current passing between dissimilar metals in water. The electrical current develops from the difference in relative potentials or voltages of the metals in sea water. The least similar metals are in potential, the more galvanic corrosion occurs. For this reason, Cape Dory uses fittings below the waterline with the most similar potential in the galvanic series and bond each fitting together with an external ground plate.

A sacrificial zinc anode is provided on the propeller shaft of each boat. It is called a Perry Nut and its purpose is to reduce galvanic corrosion of the underwater fittings by sacrificing itself and being eaten away rather than the other fittings.

With stray current corrosion, you will find similar corrosion of external parts. However, this corrosion is caused when a direct current from a battery or other source makes contact through sea water with metal parts and is usually more severe in results. A zinc anode will lessen the effect of this but not correct it. Check and maintain wire connections on switches and thru hulls to keep equipment in normal working order to insure against electrolysis or other problems developing. Stray current corrosion can be stopped immediately by disconnecting the batteries and the shore power from the boat's electrical system.

Electrolysis can occur from sources other than one's own boat. Depending on the composition and characteristic of the local waters, it will either be minimized or enhanced by electrical leaks from faulty shore power installations, misused battery chargers, or currents generated from adjacent boats.

Maintain a close check of underwater fittings to correct any problems early should they occur.

IX. FRESH WATER SYSTEM

The Cape Dory 270 has a 46 gallon polypropylene tank located on the port side under the settee. The water fill plate is located outboard along the port side deck adjacent to the head. When filling the tank it is best to have someone stationed below to observe the tank filling up. The inspection plates on top can be removed to monitor the water level in the tanks to avoid over flow through the vent line into the hanging locker in the head. A vent line runs up inside the wet locker to the underside of the deck. The pick up tube extends into the forward end of the tank and runs back under the port berth top to the galley. Access to all tank fittings may be gained through holes cut in the top of the

berth. If removal of the tank is necessary, the extension top and permanent top of the settee can be removed. There are two plates in the tank top for inspection or clean out which may be necessary should water be allowed to sit for a long time.

If water is left standing in tanks for an extended period of time, it may adopt an unappetizing odor and appearance. If flushing the tank does not eliminate this problem a mild solution of baking soda may be used. After letting the baking soda stand for several hours the tank and water system should be flushed thoroughly before refilling with fresh water.

All plumbing is done with 1/2" ID reinforced PVC hose which is lead to the galley sink and vanity sink pumps. The hand operated fresh water pumps located in the galley and head areas are self-priming. If a pump fails to operate, check first to be certain that there is water in the tank, and then to see if the hose is kinked or being constricted by some heavy object. If the hose is clear and the pump still fails to operate, disassemble the pump and inspect the operation of the internal check valve.

PRESSURE WATER SYSTEMS

In a pressure water system, hosing used beyond the pump is 1/2" grey polybutylene hose. All connections are made using standard 1/2" Qest fittings.

The pressure water system is activated by a circuit breaker switch on the D.C. Panel. Once the system is switched on, the pump maintains a pre-set pressure at all times. When you open one of the faucets, the slight decrease in pressure, which results, is sensed by the pressure regulator built into the pump. The pump starts and runs until the faucet is shut. The pressure then builds back up and the regulator shuts off the pump.

The water tank feeds to a 1/2" copper manifold which is valved to allow separate use of the manual pump in the galley. When using the pump, shut the valve leading to the galley hand pump off.

Coming off the other side of the manifold is the line leading into the PARR 1/36400-000 strainer and then into the SURE FLOW #220-21334 pump. The water leaves the pump at 25-35 PSI and goes to a "T" fitting. Here the cold and hot water systems separate.

WATER HEATER AND START UP

On the hot side of the "T" fitting there is a check valve to prevent hot water from backing into the cold water side and a manual shut off valve used to isolate the hot water system for trouble shooting and safety purposes. From here the water goes into the hot water tank and back to a "T" under the galley sink. One side of the "T" feeds the galley sink and the other the head sink with no fittings in between. The cold water leaves the first "T" and passes back to a second "T" under the sink, and

then on to the two sinks with no intervening fitting between the faucets and "T".

Start-up varies depending when your boat was shipped from the factory. Boats shipped between April 15 and September 15 do not have antifreeze in them while the boats shipped September 15 through April 15 do.

On boats which have antifreeze in them, the valve leading into the hot water side of the system was kept closed and only the cold water side of the system was tested here at the factory. This water should be flushed out and then the hot water side filled. The antifreeze used is safe for portable water systems and is manufactured by Sudbury Laboratories located at 6 October Hill Road in Holliston, Massachusetts 01746. The telephone number is 617-429-7900. BE CERTAIN THE HOT WATER TANK IS COMPLETELY FILLED BEFORE TURNING THE 110 VOLT HEATING ELEMENT ON OR IT WILL BURN OUT THE ELEMENT. Also be careful not to accidentally activate the high temperature, high pressure relief valve which projects out from the side of the tank. Once the lever arm has been pulled, the valve will not reset and it must be replaced.

To activate the pressure water system, fill up the tank and open the valve on the manifold. We suggest you run the pump and open the cold water side of BOTH faucets until a steady flow of water comes out. Close the faucets and repeat on the hot water side. You must be sure to eliminate any trapped air from the system or the pump will cycle rapidly or never shut off.

We hope that we have found and rectified any problems here at the plant. However, we recommend that you always check the clear hose where it goes into the pump for air bubbles flowing in the line. If air appears, you must find its source, i.e., a leaking connection, leaking strainer, faulty manifold, or an empty tank.

Also, periodically check for a leak in the pressure side of the system. One tip off that something is leaking is the pump coming on at times when no faucet was opened. This signifies a loss in pressure which a leak would cause.

X. DRAINAGE SYSTEM

THRU HULL AND SEACOCKS

Seacocks and thru hulls are the major means of transferring liquids to and from a vessel's interior with dependability and watertight integrity.

Each seacock is solid bronze and designed for easy use and maintenance.

Each valve base has a milled caulking groove which forms an O-ring seal around the thru hull.

The handle rotates a full 180 degrees in two off positions. When the handle is positioned 90 degrees to the base, the sea cock is open.

Two drain fasteners are located to either side of the seacock housing and can be used to drain the valve during its lay up period.

Before launching, and regularly throughout the season, you should check to see that all hose clamps are tight and in good condition. Seacocks are designed to provide a positive means of stopping a flow of water into the hull, should a connection fail or hose rupture. These fittings are the single most important safety devices affecting the watertight integrity of your boat. Checking them for ease and effectiveness of operation means making certain that the handles move the full 180 degrees arc that they were designed for and that sinks, toilets, and cockpits drain easily when filled.

Whenever the boat is left unattended in the water, all thru hull fittings should be left in the CLOSED position except for those serving the cockpit scuppers. Be certain to open the engine cooling seacock BEFORE starting the diesel engine. The water pump impeller could be damaged and/or the engine and exhaust system damaged by overheating if the engine were to be started with the seacock closed.

Routine maintenance of seacocks calls for disassembling them when the boat is out of the water, applying a waterproof grease to all friction-bearing parts and reassemble. When disassembling seacocks, do so one at a time as the components are individually fitted to each other by their manufacturer. Your dealer or marina will suggest a good grease available in your locality. Automotive water pump grease or lubriplate may be used.

Seacocks should be worked frequently to keep corrosion from forming, causing them to jam.

Your seacocks for the cockpit drain should almost always be left open. Their primary function is to be able to shut off a flow of water should the drain hose burst or come disconnected. Because these are the least used seacocks on the boat, there is a tendency to forget that they are there. DON'T! Work them frequently, and service them annually so that they will work should an emergency arise. Leave all sea cocks open when the boat is stored for the winter so there is no freezing damage.

The other sea cocks should normally be left in the closed position when you leave the boat. Be sure that you establish a routine of opening and closing sea cocks so that you don't overheat your engine or burst hoses in the head. The head bowl is near the waterline and particular attention should be paid to the sea cocks that serve the head. They should be shut off anytime you are asleep or off the boat. A malfunction in the head or leaving the head intake valve open could cause the boat to flood or sink if undetected. Simply closing the seacocks eliminates this hazard. Set up a routine to do this all the time.

Seacock Maintenance

With proper maintenance, your solid bronze Spartan Seacock, will provide years of adequate service.

Winterizing

Make sure if the boat is hauled during a freezing season that the water is properly drained from the seacock plug. This can be accomplished by leaving the seacock open during hauling out. If the boat is kept in the water during a freezing season there are winter drain fasteners (Fig. A) located on the sides of the valve to allow water to exit when the seacock is closed.

Caution: Water left in the seacock to freeze will distort the metal and potentially fracture the casting.

Lubrication

The Spartan Seacock is designed to be disassembled for greasing and fine tuning. (Fig. B)

1. Holding the handle¹⁵ unscrew the jam nut¹⁰ and flange nut¹¹ off the plug threads¹⁴. The position washer¹² can then be lifted off. Lightly tap the plug¹⁴ out of the body¹³ with a soft hammer or wood piece.
2. Use a grease cutting solvent to clean the valve plug¹⁴ surface and body¹³ plug housing. Note

any surface gouges. These can be smoothed with fine emery cloth. Lapping compound is available from Spartan Marine Products, Inc. to aid with severe surface problems.

3. Generously apply a new skin of water pump grease on the plug¹⁴ surface. Insert the plug in the body¹³ and locate the position washer¹² properly on the end of the plug¹⁴. (The position washer should turn with the direction of the plug.) Screw the flange nut¹¹ onto the plug¹⁴ thread and hand tighten. Follow that with the jam nut¹⁰.
4. Tensioning the plug¹⁴ is done by holding the handle¹⁵ and tightening the flange nut¹¹. The tension on the plug should be adequate to hold it in place when subjected to engine or other normal boat use vibration. Do not make it too tight to operate. The flange nut¹¹ is locked in place by seating the jam, nut¹⁰ securely next to it. .

ANNUAL MAINTENANCE IS SUFFICIENT TO SUSTAIN PROPER SEACOCK OPERATION.

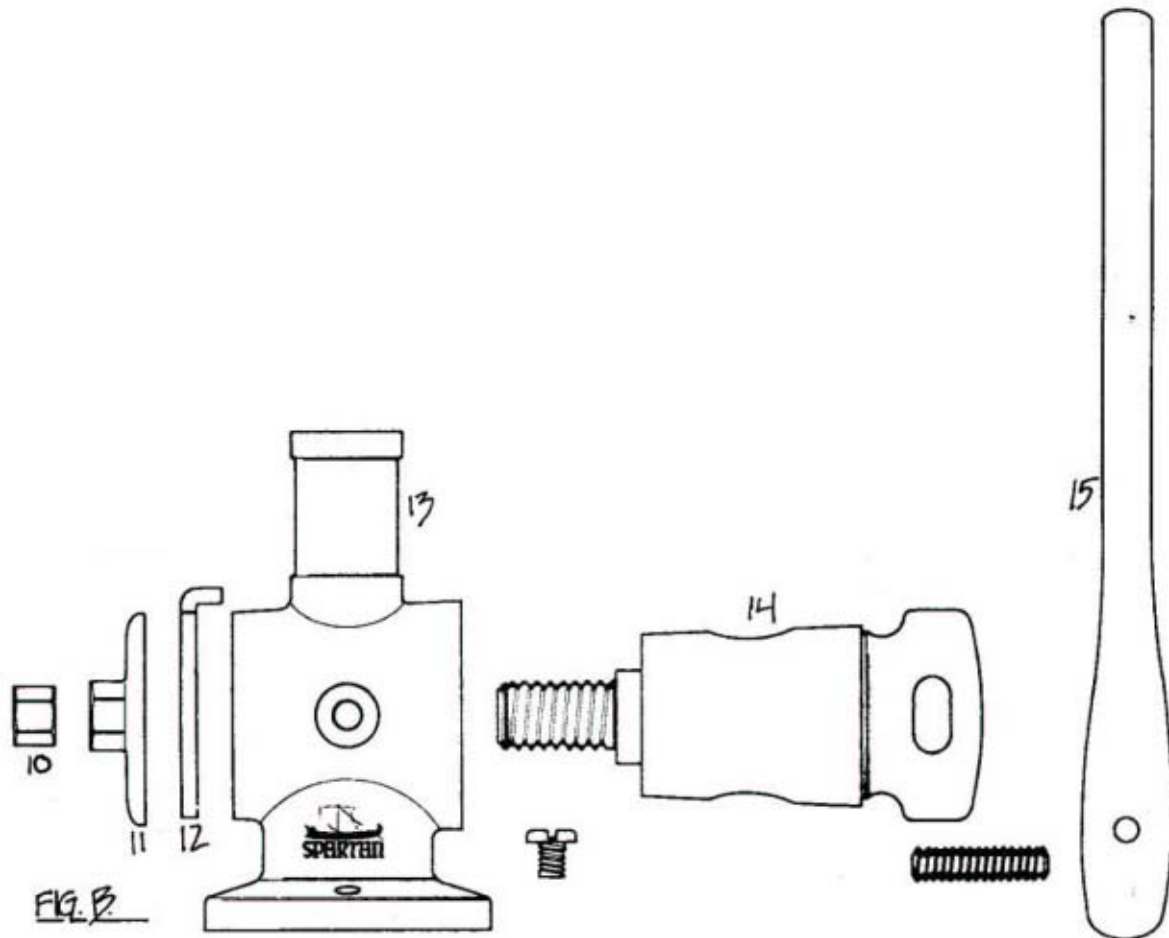

SCUPPER DRAINS

The cockpit scupper drains on your Cape Dory use multi-ply wire reinforced hose throughout. The hose sizes are 1-1/2" or 1-5/8" inside diameter hose depending on model year of your boat. All connections are sealed with gasket sealer and secured with stainless steel hose clamps. Scupper drains and galley sink drains discharge overboard below the waterline. Protect these hoses from sharp objects and chafe. Inspect hose clamps for security regularly. Hose clamps that were tight when the boat was built may loosen in transit or due to the contraction of the rubber hose and should be checked often. A failure here could cause your yacht to sink should the seacock be left open.

BILGE PUMP

The Cape Dory 270 is equipped with a permanently installed diaphragm-type bilge pump. The pump itself is located in the cockpit area and is operated by inserting the (removable) handle into the through deck fitting. This arrangement allows the pumping of the bilge with all hatches closed; a safety precaution should you have, to pump in severe conditions.

Water is carried from the bilge to the pump by a reinforced plastic hose with a strainer at the bilge end. This strainer should be checked FREQUENTLY and cleaned as needed. The pump discharges water overboard through a fitting located above the waterline near the transom.

The pump is designed to pump water containing a variety of debris, but can become clogged by excessive solid matter. If the pump should fail to prime itself after several strokes, check to see that the pick-up hose is positioned properly, then check the pump body for debris. The rubber diaphragm may be removed by loosening the screw which holds the stainless steel clamp. Inspect the pump body for foreign material and gently lift the intake and outlet flapper valves to determine that they are clear. Reassemble the pump and continue pumping. Another problem causing the pump to not prime could be a chafed hose. This can be checked by holding your hand over the end of the hose to see if suction is felt.

It is wise to pump the bilge before casting off and again on returning to see if the boat is taking on unusual amounts of water.

Note: If you decide to have an electric bilge pump installed, be sure to consult an expert on the wiring and plumbing of that piece of equipment.

XI. HEAD AND WASTE SYSTEM

The CD-270 has a 24 gallon waste tank installed under the V-berth.

Refer to the head manufacturer's instructions on use of the marine toilet. It is recommended that a minimum amount of flushing water be used on each cycle to maximize the capacity of the holding tank. There

is a deck pump-out fitting conveniently located in the anchor well from which your marina can pump out the tank.

All tanks have a 3" access cover on the top for inspection and clean-out. The use of deodorizing chemicals as sold for recirculating toilet systems is recommended to control odor. The tank and head should be winterized by cleaning and treating them with a "Winterguard" type antifreeze. Winterguard is a non-toxic antifreeze which can also be used to winterize your fresh water systems.

In certain sailing waters where pump-out facilities are not available it may be necessary to install onboard holding tank pump-out equipment. We recommend a 1-1/2" hose tee be placed in the line from the tank to the deck fitting and that a pump be installed from this tee. The pump can either be a Whale Gusher GP-10 manual diaphragm pump, Whale urchin manual diaphragm pump or an electric Jabsco Macerator pump (model #17260-0003). The discharge from the pump can either be lead to a seacock or a hose for dockside tanks. Please refer to the latest regulations for your area to determine which system is best for your boat. A vented loop is recommended in all head discharge lines that lead overboard. See the drawings at the back of this manual for details of head plumbing systems.

Some boats are set up, as an option, with direct overboard discharging capability. This system incorporates a Y valve at the tank inlet fitting below the bunk top for redirection of wastes overboard.

The overboard discharge seacock in this system is a 1-1/2" seacock with thru hull located below the vanity cabinet in the head. Make certain that this seacock is open when pumping overboard; otherwise pressure will drive the waste elsewhere or rupture internal valves in the head system itself.

When leaving the boat unattended close all seacocks associated with the head system.

Do not flush paper towels, rags, sanitary napkins, etc. into the system as clogging overflow and damage will occur.

XII. CENTERBOARD SYSTEM

One of the most unique features of the CD-270 is that it is a centerboarder. Unlike the other Cape Dory yachts which feature deep draft full keels, the 270 has a shoal draft keel with an efficient molded fiberglass centerboard housed in centerboard trunk, integrally molded with the hull.

The centerboard itself is molded in two halves with a unidirectional laminate, additional reinforcement is added in areas of stress (i.e., pennant pin, centerboard pin, and hull intersect). The two halves are clamped together with a 25# lead insert placed at the lower end. The entire board is then filled with a microsphere and resin mixture forming an internal bonding matrix for the centerboard.

Factory tests have induced loads on the centerboard far above even extreme conditions without failure of the laminate or the internal bonding.

The centerboard and trunk are primed and bottom painted prior to installation. Then, the centerboard is secured in place within the trunk with a 1" diameter stainless steel pin passing through the pin tubes and held in place with polyester bonding putty.

The 1/4" centerboard pennant attaches to the upper trailing edge of the centerboard with a 1-3/4" x 3/8" clevis pin through an eye spliced thimble. The line passes through the top of the molded centerboard trunk into the fiberglass table base.

A teak trimmed fiberglass table base in the main cabin is secured to the top of the centerboard trunk with epoxy and glass tape. This base serves as a housing for the tackle system which lowers and raises the centerboard.

Within the table base, the pennant attaches to a tackle system.

Two systems have been developed for this. One system provides the means for adjusting the attitude of the centerboard from below and the other from on deck.

By attaching the 1/4" dacron braid line centerboard pennant to a 4:1 tackle system within the table base, the board is easily raised or lowered by hand~

The tackle system is made up of a double sheave block (one with a becket) and 3/8" dacron braid line eye spliced to it. (Refer to diagrams in this manual for details of each system.)

The centerboard reduces leeway and produces lift improving the boats windward ability. In light air, it may not be necessary to use the centerboard at all. Down wind as well as under power the centerboard is generally retracted fully into the centerboard trunk for less resistance, greater maneuverability, and shallower draft.

Many times you will find that with certain sail combinations, points of sail, and sea conditions, more or less weather helm is desired. By adjusting the attitude of the centerboard, you attain the desired balance and feel of the helm. Pull the centerboard aft to reduce weather helm and swing the board forward to increase weather helm.

You may hear the centerboard, as it shifts with the roll of the hull or while tacking, make a slight thud. This is normal behavior for all centerboard systems under certain conditions.

To inspect the centerboard system, remove the fasteners at the top of the table base which hold the table top in place and remove the folding braces from the table top. Lift the table top off the table base to inspect or service parts.

Check all attachment points of the pennant and tackle line. Check the blocks, clevis pins, and circle pins for wear. After each sailing season, check the pennant attachment to the board when the boat is being hauled and in the slings. Before the next season begins, paint the trunk and centerboard again with the board in the slings and inspect all parts in the system to insure that they are in proper working order.

If the centerboard gets jammed inside the trunk, due to some debris between it and the trunk wall, it may be loosened with a mop handle or something similar pushed through the centerboard pennant passage hole within the table base. Do not strike the trailing edge sharply as it could damage the board.

To remove the board, the boat needs to be in slings on a hoist or travel lift. Take great care when removing the board as its weight on land is much greater than it seems in water. Dry weight of the centerboard is approximately 80 pounds.

The location of the centerboard pin is as illustrated in the centerboard drawing. Putty has been used to hold the pin in place and must be ground away to remove the pin. Take great care in this process. Contact your dealer or Cape Dory Yachts for any additional information.

XIII. SPARS, RIGGING, AND SAILS

The mast on the Cape Dory 270 is deck stepped on a compression post member extending from the underside of the deck to the ballast. The mast step is fastened in place on the deck with 4, 3/8"-16 HH bolts tapped into an aluminum plate sandwiched between the headliner and deck.

The mast and boom are both made from 6061-T6 aluminum extrusions. Both are anodized with a clear finish which provides the best means of protecting the aluminum spars. Anodized spars require little maintenance except for an occasional thorough wash down with fresh water.

When they are removed from the boat for the winter, they should be thoroughly washed with plenty of fresh water and a mild detergent. After a complete rinsing with fresh water, and after all halyards and lifts have been neatly tied-off to prevent tangling and fouling, a thorough inspection should be made. Start at the base of the mast. Water will collect here if the drain hole in the mast step has not been kept clear. This may hasten the breakdown of the anodizing and start the corrosion process. If water has collected and caused corrosion, clear the mast step drain hole and refinish the mast base or heel. Waxing will help preserve anodizing.

Proceed up the mast noting any areas that are scratched or abraded. If these are small, they may be covered with a clear lacquer of a mast-kote type product to keep corrosion from starting or spreading. It is recommended that you apply to the mast a good hard wax as this helps to protect it further. As you proceed up the mast, check every cleat and

fitting for tightness, and for corrosion which may have begun in the screw holes. Make certain that no bronze, brass, or iron fastenings are used on the aluminum as the two metals are incompatible and galvanic corrosion will start at once.

Check the tang fittings of the lower shrouds and the base mounts of the spreaders as you proceed up the mast. Carefully check all tangs, straps, and fittings at the masthead.

Examine the main and jib halyard sheaves for signs of wear or needed maintenance. If you see anything that looks at all unusual, ask your dealer or local boatyard for assistance. Booms should also be inspected carefully, with particular attention to gooseneck fittings, sheet blocks, and bails. The combination bow and stern light should also be checked. It is good practice to change the bulbs every year as a mid-season failure is very difficult to correct. Record bulb sizes and carry spares aboard your boat.

The spreaders that support the upper shrouds should be inspected. They are designed to angle slightly upward to best support the mast in column. The inboard and outboard ends should be covered with chafe tape or spreader boots to prevent tearing sails or halyards. DO NOT sail with defective spreaders, spar, or hardware. We do not recommend that a spar be left stepped all winter, especially in northern climates where the boat may only be used for 1/2 year.

STANDING RIGGING

Standing rigging consists of shrouds and stays which support the mast in an upright position. Running rigging is used to hoist or trim sails. Standing rigging requires attention, as failure could result in the loss of a mast. Lack of attention, poor tensioning, or improper maintenance are the causes of most rigging failures.

Before stepping your mast each season, inspect all standing rigging thoroughly. Starting at the top of the mast, systematically check each upper shroud and stay tang and be certain that each clevis pin is secured with a properly placed cotter pin with its ends bent over. Wipe down each shroud and stay with bronze wool dipped in a solution of water and mild detergent. The bronze wool will catch any broken wire in the rigging, calling attention to potential trouble; use bronze wool as unlike steel wool it will not leave particles to rust and soil your sails. Follow the bronze wool with a piece of terrycloth sprayed with a water-dispersing agent, such as CRC or WD-40.

Next, see that the spreaders are firmly fastened in place, and that the upper shrouds are locked in place on the grooved end of the spreader with a short length of stainless steel wire. You should use a spreader boot or some other form of chafing gear to protect your sails from the spreader tip. Check the mast tangs, clevis pins, and cotter pins for the lower shrouds as outlined above for upper shrouds and stays.

Prior to stepping the mast, be sure that halyards are properly reeved. Tradition indicates that the main halyard's hauling part is always

secured to the starboard side of the mast, and the jib halyard is secured on the port side.

After checking each piece of standing rigging for broken wires, rust spots, and for secure clevis and cotter pins, inspect the swaged terminal fittings at the ends of each shroud and stay. These fittings should all be examined, using a magnifying glass, for any hairline cracks. These cracks sometimes develop after water has entered the body of the fitting (by following the lay of the wire) causing the wire to corrode and expand. Although this problem is more prevalent in the southern latitudes, many owners seal the space between the wire and swages with bees wax. Turnbuckle boots are also quite popular, but are not recommended by Cape Dory as they cover turnbuckles which should be inspected frequently. We DO NOT recommend oiling or greasing the swage fittings as a means of preventing water from running inside them.

Report to your dealer any fittings that you find to be defective. Wire and fittings with any of the following defects require replacement: kinked wire, wire with broken strands, cracked swage fittings, bent turnbuckles, turnbuckles with stripped threads, clevis pins with grooves worn in them, and tangs or other fittings with distorted holes. The existence of any of the aforementioned conditions should be investigated, the reasons for them determined, and corrective action taken.

After completing the above inspections, the mast may be stepped and the standing rigging secured to the chainplates. In all Cape Dory yachts the upper shrouds are attached to the chainplate in a direct line athwart ships to port and starboard of the mast step. Lower shrouds are attached fore and aft of the uppers.

TURNBUCKLES

Cape Dory boats are equipped with open body integral toggle turnbuckles. Prior to every sail, all turnbuckles should be checked to see that they are properly adjusted (see section on Tuning) and above all, pinned, so that they will not loosen. The two cotter pins should be inserted and spread open. The threaded sections above and below the barrels may be taped once the turnbuckles are adjusted and locked in place. Engine vibration and even wave action at mooring or slip are enough to allow an improperly pinned turnbuckle to work loose.

Occasionally, during the season, you should completely disassemble and inspect all turnbuckles. Do NOT attempt to do this when sea or wind conditions are placing strain on the mast. The shroud turnbuckles (upper and lower sidestays) may be disconnected and inspected ONE AT A TIME. The remaining shrouds will provide adequate mast support.

Prior to disconnecting headstay and backstay turnbuckles for inspection, special measures to support the mast are necessary. This can be accomplished by using the halyards as temporary stays. Attach the jib halyard to the jib tack shackle; haul it in tight and cleat it. This will temporarily replace the headstay, so that you may disassemble the turnbuckle for inspection. Lead the main halyard aft to a stern cleat

and follow the above procedure to check the backstay turnbuckle. Do not use the coaming mounted genoa sheet cleats for anything other than sheeting the genoa and then only if the sheet is around the winch first. These cleats are handily mounted but may pullout of the coaming if the main tension of the sheet is not taken by the winches.

The barrel section of the turnbuckle should be backed off entirely from the top and bottom sections. All threads should be carefully inspected both for broken or worn threads as well as rust, corrosion, or breakdown of the metal itself. The threads in the barrel should be inspected as well as those on the long, threaded ends. Prior to reassembling, lightly lubricate the ends, barrel, and locking nuts with waterproof grease.

RUNNING RIGGING

Because of recent technical advancement made in the manufacturing of synthetic fibers and the problem encountered when wire halyards develop "meat hooks," each CD-210 is supplied with carefully selected low stretch dacron rope for both the main and jib halyards.

Periodic inspection of the running rigging will point out any areas of excessive chafe. Often the offending item causing the chafe can be corrected. Otherwise, one way to extend the life of the rigging is to either end for end it or move the shackled end of it up a foot or so every year to move the point of wear away from the sheave, winch turning block, etc. Only experience will dictate when replacement is necessary.

Drawings are included to illustrate the correct reeving of the mainsheet. Swapping the sheet end for end will extend useful life if it has started to chafe where it passes a sheave or engages a cam cleat.

All running rigging on Cape Dory yachts is Dacron Braid. It requires only protection from chafe and the ultraviolet rays of the sun. Stow in neat, seamanlike coils when not in use so that it will run freely without knotting itself when it is needed. Rinsing in fresh water throughout and at the end of the sailing season is recommended.

TUNING THE STANDING RIGGING

The purpose of tuning the mast is to adjust the center of effort of the sail plan fore or aft to obtain a slight weather helm in moderate winds, to keep it straight without undesirable bending to port, starboard, or fore and aft, and also to insure correct tension in the shrouds and stays. Properly tuning the rig is an important part of the commissioning process which should be attempted only by qualified personnel; consult your Cape Dory dealer.

The fore and aft alignment of your mast can be checked by comparing it to a vertical structure such as a radio tower, chimney, etc. Before checking the mast alignment in this manner, be certain that the boat is resting on her design waterline. If the mast is leaning fore or aft, ease the turnbuckle toward which the mast is leaning a few turns, and take up a corresponding number of turns of the opposite turnbuckle.

Always prevent the upper threaded turnbuckle stud from turning. Headstays and backstays should never be taken up so tightly that they will not "give" an inch or so if you pull on them with moderate force.

Upper shrouds should also be tightened equally and have about an inch of "give" to them. Forward lower shrouds should have one to two inches of "give," and the aft lowers slightly more.

UNDER NO CIRCUMSTANCES TAKE UP THE RIGGING TO BAR TIGHT TENSION. Both the mast and the boat can be damaged by excessive tension.

Fine tuning of the rig can be completed after the boat has been sailed, and may have to be done again after the boat has been out in strong winds. When sailing, it is important that the mast remain straight and as nearly in column as possible at all times. While sailing close hauled, sight up the mast and note any mast curve. Does the mast appear to be falling off to leeward at the top, or does it hook to the weather side? Repeat this procedure on the opposite tack.

If the masthead is falling off on both tacks, the forward lower shrouds are too tight and the upper shrouds are too loose. If the masthead hooks to windward, the upper shroud is too tight in relation to the lower on the same side. When sailing to windward, the forward lower shrouds bear a greater load than the after lower shrouds; however, the after lower shrouds on the windward side should never be loose. All shroud tuning should be done from the leeward side. If the rig seems to be equally balanced when you begin, duplicate every half turn from side to side.

CHECK TO SEE THAT ALL COTTER PINS OR RINGS ARE IN PLACE AND THAT ALL SHARP EDGES ARE TAPED.

Rigging that has split strands of wire or cracked swage fittings should be discarded and replaced.

DECK HARDWARE AND CHAIN PLATES

Most deck hardware is thru-bolted and backed up where necessary. Periodically these items can leak and should be rebedded with a good brand of caulk such as "3M 5200" or Sikaflex 241. Care must be taken not to overtighten the fasteners as the strength can be reduced severely. Particular attention should be paid to the chainplate fasteners as they are very critical to the safety of the rig. The chainplates were torqued at the factory and when recaulking them you should not exceed the torques listed below:

1/2" bolts	200 inch pounds
3/8" bolts	150 inch pounds
5/16" bolts	90 inch pounds

CHAIN PLATE SYSTEM

Our chainplate system is easy to understand and does what any chainplate system must do - transmit the rigging loads to the hull AND NOT LEAK.

We use chainplate castings with substantial base areas so that when installed and caulked the resulting seal is impervious to water penetration.

Every Cape Dory chainplate design has been subjected to structural evaluation including destructive pull tests assuring that they meet our structural requirements. All bolts are tightened to specific tolerances using a torque wrench.

The rigging was designed using a safety factor of 3 while the chainplates were designed to meet a minimum safety factor of 4.

Please refer to the drawing for further details.

The Cape Dory 270 differs from other boats in the Cape Dory line in that the shrouds are inboard on the side deck rather than outboard along the sheer.

New systems of attaching them and transferring the loads were required due to this arrangement.

Cape Dory designed its own bulkhead mounted bracket for attaching the chainplates down to the deck. A detail of this arrangement, used on the upper and forward lower shrouds, is included in the drawings section at the back of this manual. The aft lowers connect via a Navtec tie rod system to a fiberglass chainplate reinforcement glassed to the side of the hull. This chainplate reinforcement has been tested beyond the breaking strength of the 3/16" shroud wire without any damage to the tie bar or glass part. The tie bar is tensioned with an adjustable wrench placed on the flats along the tie rod. Silicone is used to prevent movement of the aluminum crossnut within the chainplate reinforcement. An illustration of this arrangement also appears in the back of this manual.

SAILS

Each Cape Dory 270 comes with a sail package containing mainsail and jib.

Each mainsail is set up with reef points, reinforcing patches, batten pockets, and battens.

The varying wind and sea conditions encountered on various points of sail require a range of adjustments to your mainsail to get the best performance from your boat.

As the wind speed increases, the shape of mainsail should be changed from being full with the draft centered and the traveller set to windward of centerline to being fairly flat with the draft forward and the traveller set to leeward. Generally this is referred to as depowering the mainsail. With proper mainsheet, halyard, and outhaul adjustments, your mainsail can be used to control heeling and the speed of your boat.

Reefing is necessary when angles of heel with a depowered main begin reaching 25 degrees or the range of personal discomfort.

"Jiffy" reefing is the most common term for the style of reefing the Cape Dory 270 was designed for. In this type of reefing, a new clew and tack point are brought down to boom level and foot tension is applied with the reef line which passes through the new clew or first reef cringle. The tack ring slips over a reef hook on the gooseneck.

Reeve the reefing lines through the reefing cringle. The grommets on the luff and the leach will then become your new tack and clew. Ease off the halyard and pull the tack down to the top of the boom. Attach the reefed tack point to one of the reefing hooks at the gooseneck and take up on the halyard until the luff is set with the proper tension. Next, haul on the clew line, pulling the clew down and aft. The clew line runs from a padeye up through the grommet, down to a cheek block and forward to a cleat. It is important that during a jiffy reef the main sheet and the vang, should your boat have one, be eased to allow proper tensioning along the new foot of the sail. The key to this type of reefing is to have sufficient tension on the foot of the sail. When the clew has been pulled out and the foot is tight, make the line fast around the cleat on the boom.

There are reef "points" -in the mainsail of Cape Dory Yachts fitted with "jiffy" reefing. Use 18" lengths of 1/4" line and run them through each reef point. Lead the line through the reef point, under the foot of the sail and tie the reef lines in a REEF KNOT. It is the seamanlike procedure to keep the unused sail out of the way and reduce windage.

To shake out the reef, release the lines through the reef points, stow them and release the reef line through the reefing cringle that is serving as your clew. Then release the new reefed tack point and hoist the mainsail, retensioning the luff. Return the topping lift to its original position. Again, make sure the sheet and vang have been eased. Never attempt the reefing process with the sails full and drawing.

The enclosed explanation of "quick reefing" is from the catalogue of Schaefer Marine Products of New Bedford, Massachusetts. It is reprinted here with their permission.

The jib you receive with your Cape Dory 270 has hanks for attaching the luff to the head stay. These are very handy in dropping sail with the security that you won't lose the sail overboard in rough conditions. The sail may be tied with nylon tie downs to the stanchion bases nearby. Tie the head of sail down to prevent damage to the halyard or the sail. The jib sheets back to a genoa block at the forward end of the genoa track and then to a winch. The jib can generally be used in winds up to 35 knots with 2 reefs in the main. After this, it would be wise to drop the jib and proceed under reefed main alone.

QUICK REEFING*

As the modern offshore racing yacht rapidly becomes more sophisticated, and offshore racing itself becomes more challenging, hardware and sail handling systems are refined and developed to make yachts faster and easier to operate. Perhaps the most important development in the area of sail handling has been Quick Reefing.

Time was when the call to reef meant a sacrifice of speed, time and lots of crewmen on deck. Quick Reefing has changed all this. It is very fast, requires few hands and retains proper sail shape.

Although sophisticated refinements have been developed, the basic system is simple and effective. Installation or conversion is easy, and the benefits of this line system are appealing to racer and cruiser alike.

The basic Quick Reefing system is shown as Method A. A newer, simpler system, in which a gooseneck hook replaces the reef tack downhaul and a single ended cheek block and sliding loop arrangement holds the clew, has been developed recently, and is shown as Method B.

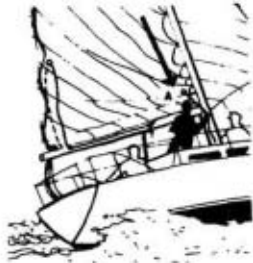

1. The halyard is released and the reef tack downhaul (A) is tightened until the reef cringle is drawn down to the gooseneck then cleated. (Pre-marking the halyard provides a good reference when releasing).



2. The main halyard is tightened up. Note: The mainsheet should be stacked only if necessary. (Usually when releasing).



3. The reef clew outhaul (B) is tightened up to the reef cringle and cleated. With practice, a Quick Reef can be executed in between 15 and 30 seconds on a boat of 40' (12.2 m) in length!

Installation

Follow these steps in conjunction with the diagrams to the left.

1. Position the boom at or slightly below black band (A).
2. Attach eye strap (B) at or slightly below black band (A) on the port side of the mast, angled toward the reef.
3. Attach cleat (C) at or below black band (A) on the starboard side of the mast.
4. Attach cheek block (D) near end of boom on the starboard side. See diagram for exact positioning.

5. Attach eye strap (E) on port side of boom approx. 4" (101 mm) aft of cheek block (D).
6. Attach cleat (F) just aft of the gooseneck on starboard side of boom.

7. The clew outhaul and tack downhaul reefing lines are now reefed into position as shown in the diagrams to the left.

Lengths are determined as follows:

Tack Downhaul — Two times the depth of the reef plus approx. 3 extra feet (91.4 cm).

Clew Downhaul — Two times the reef depth plus the length of the boom.

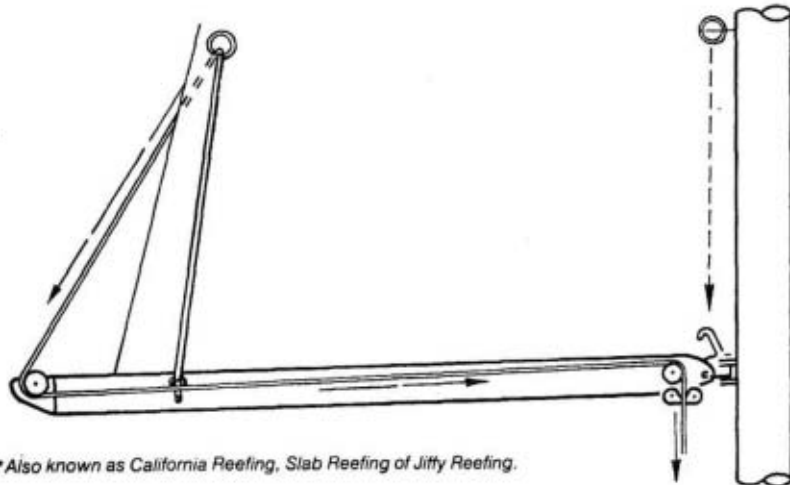

*Also known as California Reefing, Slab Reefing of Jiffy Reefing.

Jiffy Reefing Kits

To make it easier for you to obtain a complete jiffy reefing kit, three packaged kits are available for the following boat sizes: 14'-19' (4.3-5.8 m), 20'-30' (6.1-9.2 m), and 31'-45' (9.5-13.7 m). The components are also available individually and you will find complete details and specifications for each in the appropriate sections of this catalog. Note: One kit required per reef (two reefs, 2 kits, etc.). Self-tapping screws are recommended.

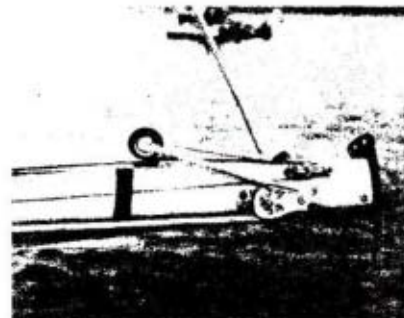

Typical Single Reef

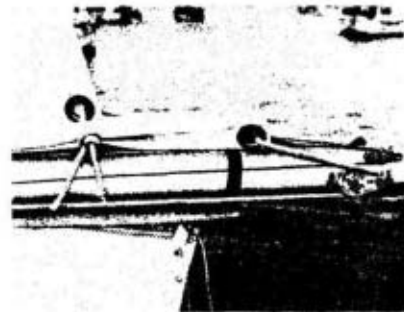

Typical Double Reef

If headsails larger than the standard jib are used, a genoa turning block must be installed aft of the winch to fairlead the sheet and decrease loads on the winch stand by sheeting directly from the track.

The outboard tracks installed along the toe rail aft are for the sheeting of an MPS type sail.

OPTIONAL SAILS

The first sail that you will probably want to add to the complement of working sails provided with your Cape Dory is a 150% genoa. This sail provides more power and speed in lighter wind conditions and is particularly effective going to windward. Cape Dory has genoa and genoa gear packages for the CD-270.

If you choose to add a spinnaker or other sails to your inventory, select your equipment carefully. Your Cape Dory dealer will assist you in selecting suitable equipment and will make you aware of the optional sails and equipment that Cape Dory has available. Due to a very low demand for spinnaker gear Cape Dory cannot supply any system other than the fittings attached to the mast. A popular sail which acts like a spinnaker and a reaching genoa is a flasher. This sail is also known as a MPS (Multi-Purpose Spinnaker). It does not require a spinnaker pole and is easier to set and trim than a spinnaker. Most Cape Dory brochures show this sail.

XIV. STEERING SYSTEM

The rudder post on all tiller steered Cape Dory yachts extends well above the waterline, and occasionally when heeling or in a sloppy and confused chop, water will enter the cockpit through the fitting at the top of the rudder post. This is not cause for concern as the volume is minimal and will drain out the cockpit scuppers.

Maintenance of the tiller-steered Cape Dory system is simple: keep the bearing at the top of the rudder post lubricated with a good waterproof grease. Tilt the tiller upward and apply the grease to the top of the shaft and bearing. Inspect the condition of the key. Inspect the gudgeon, the heel fitting at the base of the keel where the rudder is connected. There should be very little play at that point.

If the tiller cap is removed from the head of the rudder post, be certain to re-install the tiller cap properly. Both the rudder post and the tiller cap have machined keyways in them. Be certain that the key is in the keyway and that the tiller cap is installed correctly.

Refer to the drawing in the back of the manual for a better understanding of your steering system.

PEDESTAL STEERING

The optional pedestal steering system on your Cape Dory has been carefully designed, installed, and aligned here at the factory to give you excellent service with minimal maintenance.

The system is composed of a pedestal steerer with a 22 inch stainless steel wheel. The chain and cable assembly travels through a pair of idler pulleys thru bolted to the underside of the deck and connect to an 8" radial drive wheel. This system provides 1.6 turns hard over to hard over.

The rudder itself is guided by an upper shaft and lower gudgeon bearing with a stainless collar below the upper bearing to prevent the rudder from jumping.

A 1-1/8" stuffing box guides the shaft through the hull. This stuffing box requires 1/8" flax packing for replacement, 10-1/2" long. Replace the packing when leaks cannot be controlled or once a year.

The radial drive stop limits the swing of the rudder to about 35 degrees both to port and starboard. This is especially useful when motoring in reverse, as the rudder would tend to swing completely to one side with great force resulting in possible damage to either the hull or steering system.

During installation, we have replaced many of the vendor supplied nuts with self locking nuts as we have found they will otherwise loosen during road transit, engine vibration, and general use.

It is imperative that the owner take the initiative to inspect the steering system for proper wire tension, wire alignment, and fastener tension during the sailing season. Periodic maintenance is also required on all moving parts. In particular, the lubrication of the bronze sheaves is critical to the smooth operation of the steering unit.

The keyway that is cut into the rudder shaft is purposely cut a little long to accept an attachment for a number of automatic pilot systems. This saves a very costly alteration from having to be performed in the field were another keyway to be cut and eliminates the need to bolt something through the shaft which would tend to weaken it.

The head of the rudder shaft above the pillow block bearing has been keyed to accept an emergency tiller. Access for this is gained by removing the bronze deck plate in the cockpit sole.

Should anything ever happen to your primary steering system, the key for the deck access plate and the emergency tiller should be readily accessible and not buried in the bottom of a locker.

Please review carefully the enclosed maintenance hints supplied by the vendor. A thorough understanding of how your steering system works is the only way you can be assured of its proper performance year after year.

xv. EXTERIOR MAINTENANCE

The exterior of a yacht should be maintained with great pride for it displays the value you place in it. With regular attention and proper use, the outside appearance of your yacht will remain like new.

FIBERGLASS

Fiberglass is one of the most maintenance-free materials utilized today in boat construction. If given proper care and treatment, the gelcoat surface will look new for many years. If not maintained, it will eventually turn to a dull, chalky textured appearance.

We recommend that you wash the exterior fiberglass surfaces of your boat several times each season with a mild soap and plenty of warm fresh water then rinse liberally with fresh water. After the boat has dried, use a good quality fiberglass cleaner in paste form; follow this process with a wax or polish prepared for marine use. A fiberglass cleaner with a very gentle abrasive in it may help remove minor scratches and surface wear. Be careful, as the continued use of cleaners containing abrasives will gradually erode the gelcoat surface. Marine wax will fill small scratches and provide a glossy finish. We suggest you use a wax that does not contain silicone as it gets into the gelcoat and is almost impossible to remove should you want to paint the boat at a later date.

Stubborn stains may be removed with fiberglass cleaner in some instances. More difficult stains may be worked out with judicious use of a very mild abrasive powder cleaner. Stubborn tar and petroleum stains may be removed with careful application of acetone solvent. (Acetone is a powerful but EXTREMELY flammable solvent which is available in most paint and hardware stores.)

Stress or "spider cracks" are a common occurrence on the fiberglass boats of even the most careful boat builders and boat owners. Most of the time, these cracks are limited to the gelcoat surface and are of cosmetic considerations only, not structural. If you have any doubt about the seriousness of any crack, consult your dealer. Cosmetic repair of gelcoated surfaces is not a difficult task and a reasonably handy person with a little practice and study can make adequate repairs. Structural fiberglass repairs should be left to experts.

If for any reason you desire to apply paint to areas of the boat other than to the bottom or boot-top, seek the advice of qualified personnel at a boat yard in your area for information about the latest development in chemically-based paints for fiberglass, and the recommended surface preparation procedure.

Minor repairs of the gelcoat surfaces may be done by the owner using one of the following methods:

SURFACE IMPERFECTIONS: On imperfections that do not penetrate the gelcoat, you may sand them out with #320 wet and dry sandpaper. Finish with 400 and 600 grit paper and hand buff with a fine rubbing compound.

DEEP SCRATCHES AND FLAWS: (exposed fiberglass) Thoroughly clean the damaged area with acetone to remove dirt, grease, or wax. Tape-off the area around the flaw with masking tape. Thicken a small amount of matching gelcoat with talcum powder or cabosil to obtain a putty-like consistency. When ready to apply the putty, thoroughly mix a small amount of hardener into the gel putty. A tablespoon quantity of gel putty will require ONE DROP of hardener to cure into a hard plastic in mild temperatures. Some experimenting will allow you to adjust the amount of hardener to suit your needs. Over-catalyzing results in a rubber-like substance never permitting a complete cure.

Apply the gel putty with a putty knife, filling the flaw slightly above the surrounding surface. Allow to harden. Sand and buff as previously mentioned for shallow scratches. Clean up hands and tools with acetone before putty hardens.

CAUTION: The clear hardener should be handled with great care. Flush skin or eyes with large amounts of water if contact is made with it.

Be careful when discarding uncured, mixed gelcoat material. Once hardener is added, a chemical reaction takes place that generates heat. Large quantities can become VERY hot. Submerge material in water until cured for maximum safety.

NON-SKID IMPERFECTIONS: Repair of the non-skid is similar to that of deep imperfections only that you add trace amounts of non-skid grit and stipple the gelcoat on with the end of a brush.

GELCOAT BLISTERS: Below the water line it is possible for water to get beneath the gelcoat and cause it to blister. This occurrence is rare and usually takes the form of small blisters less than 1/4" in diameter. While we try to use the latest materials and techniques in combating this phenomenon, it is not within our ability to guarantee this never happening due to the very nature of the materials used. If you should find yourself with a serious case of "measles," contact the factory for the latest recommended repair practices and advice. The successful repair is difficult and time consuming and the services of an expert repair facility is advised. To minimize the potential of blisters ever forming on your bottom, this advice is offered. Never sand your bottom gel coat off. Do not use pumice stones or a coarse sandpaper when preparing your bottom for new bottom paint. This could deeply scratch the gel coat surface which would increase the chance for water passing into the laminate. Gelcoat is a water proof barrier coating required to protect your boat's laminate, not merely a cosmetic coating. The continued use of any epoxy based bottom paint, which is in standard at CDY, is recommended.

BOTTOM PAINT, BOOT TOP PAINT

Your Cape Dory was painted with anti-fouling paint before it left the factory. The area under the cradle poppets and keel supports may require additional painting prior to launching. These areas should be well sanded with 120 grit paper and washed with solvent to remove wax prior

to painting.

Cape Dory's bottom paint system incorporates a tinted epoxy primer - PETIT UNEPOXY - which serves to seal the gel coated surface from the marine environment to help eliminate the likelihood of water being absorbed and gel coat blisters from forming.

It is recommended that a fresh coat of bottom paint be applied each year. The epoxy primer is a purple/brown tint and should not be sanded through when preparing to repaint the bottom. If this occurs, re-prime the area broken through.

In certain geographical areas some bottom paints work much better than others. If you intend to repaint the bottom of your Cape Dory, seek the advise of your dealer or knowledgeable local boat owners on what brand of bottom paint works well in your area. CAUTION: not all bottom paints are chemically compatible. Be sure to tell your paint dealer what paint is currently on the bottom of your boat to be certain that you purchase compatible anti-fouling paint.

The boot top paint is INTERLUX DADO BROWN #246. When repainting, this area should be well sanded before applying a new coat.

COVE STRIPE

The Cove Stripe is a durable plastic tape which only needs regular cleaning as the hull is washed. Do not use acetone on the tape as it will dull the surface or possibly loosen it from the hull. Cape Dory Yachts provides a replacement kit which may be purchased through Customer Service or your dealer.

PORTS AND HATCHES

Ports and Hatches may be cleaned with warm water and a mild detergent. The safety glass in the ports will resist most abrasive cleaners but the lexan hatches will scratch very easily. Rinse both thoroughly with water before washing as dried caked on salt can abrade a surface if not diluted sufficiently.

DECK HARDWARE

The Deck Hardware used on the boat is composed of bronze, aluminum, stainless steel, and plastic materials. The bronze hardware on Cape Dory yachts is made from the finest materials available and it is Cape Dory's belief that this warm, rich looking metal brings to each Cape Dory a distinctly traditional appeal. Although the stainless steel, aluminum, and plastic equipment are virtually maintenance-free, the bronze will tarnish and oxidize developing a greenish film on the surface. This film, if not checked, can run down onto the gelcoat nearby which will then have to be cleaned also.

To clean bronze, scrub with a bronze wool pad and a strong detergent. Once clean, use a good metal polish, preferable one made specifically for use on bronze.

After the metal has been brought to a bright luster, it will need a coat of some sealer to retain its new appearance. Several items may be used, however, nothing is permanent and this process will need to be repeated again when oxidation begins. A clear lacquer spray for metal can be used. However, when spots of tarnish appear and refinishing is needed, the entire piece must be wiped clean with lacquer thinner before repolishing.

A moisture displacing penetrating lubricant may be used but will require frequent reapplication to prevent tarnishing.

Another method of retaining the polished new appearance of bronze is to use a teak oil which when wiped clean provides a drying protective film over the bronze surface. This oil acts like a lacquer and yet is easy to wipe off with a mild solvent or detergent and refinish.

WINCHES AND BLOCKS

The winches installed on your yacht are the finest available. Most problems occur when a proper maintenance schedule is not followed. It is important that your winches be cleaned and inspected at least twice a season or after a two or three week offshore passage. Flush thoroughly with fresh water to remove caked on salt deposits. We recommend a high density grease and not an oil for the required lubrication. Check to see that all bolts holding the winch down are tight.

Blocks require little maintenance except periodic washing in fresh water and a light oiling or spraying with a silicone lubricant. Check all aluminum T tracks for signs of lifting or loose fasteners.

LIFELINES, PULPITS, AND STANCHIONS

Lifelines, like standing rigging, should receive periodic checks. The terminal ends should be engaged properly in the barrels of the turnbuckles and the lock nuts tight. As the lines stretch, the slack should be taken up. Check all swaging for dents or cracks.

Check pulpits and stanchions for cracks, dents, and cracks in the weld. Check that the bases are tight and properly sealed.

Periodically, some of this stainless hardware shows signs of rusting as mentioned in the standing rigging section. If after a period of time the rusting continues, contact your dealer.

SPAR

It goes without saying that removing the spar and storing it inside after the sailing season is over (northern climates only) is preferable to leaving the spar stepped or outside. Regardless of where you sail, the spar should be waxed once a season and inspected carefully.

All moving parts on the spar were treated with a Teflon lubricant when they were installed. At least once a season you should do the same.

STANDING RIGGING

Standing Rigging, the fixed rigging supporting your mast, should be inspected frequently to ensure trouble-free sailing.

New rigging will often form a thin layer of rust, especially at the terminal ends. This is caused by impurities surfacing when the wire is cold worked during the manufacturing process. The oxidation should eventually stop forming and when it does, the stain should be removed with an unchlorinated cleanser. If the rusting persists after several cleanings, contact your dealer.

Turnbuckles should be checked that there are sufficient threads exposed and that the cotter pins are in place and taped over.

The judicious use of a silicone-lubricant on sail, genoa, and traveller tracks works well to keep these running free in a salt air environment. Sheaves should be disassembled occasionally, washed, and well lubricated with a thin oil.

Check the spreaders to be certain that they are angled upward 6 degrees to horizontal. The spreader tip should be securely seized to the shroud and it all protected by some form of chafing gear.

Once a month you should go aloft and check all shrouds, tangs, masthead assembly, etc. to be certain all bolts are tight and all cotter pins are in place.

SAILS

Sails should be protected from chafe by padding spreaders and other gear or by installing chafe patches on the sails themselves. Spreader and shrouds can chafe genoas and other overlapping jibs when those sails are sheeted in tightly and can chafe the mainsail when running before the wind. Topping lifts frequently chafe the leach of the mainsails.

Inspect your sails frequently and take care of chafed stitching or small tears before they become a major problem. A small ditty bag with some thread and a few sail maker's tools on board can come in handy and save you considerable expense in the long run.

Sails should also be protected from sunlight as much as is practical. Ultraviolet light can break down the dacron in the sail cloth and stitching. Sails that are left furled on booms, jib club booms, and forestays without suitable covers are most susceptible to this problem. Suitable sail covers are available from Cape Dory through your dealer.

Mildew is no longer the major concern that it was in the days of natural fiber sails. Your new sails should be dry before folding if for no other reason than to prevent the unsightly growth of this dark mold.

In order to retain the shape of your sails, they should be folded after each use. In the case of the mainsail, outhaul tension should be relieved before folding the sail on the boom.

After the season, sails should be inspected and if necessary, serviced by a competent sail maker. For appearance's sake, stains should be removed and the sails washed gently with a mild soap and thoroughly rinsed.

Battens are thin wooden or fiberglass stiffeners inserted in the trailing edge of your boomed sails to support the outward curved leach. When inserting the batten, the thin edge goes into the batten pocket first. Battens, particularly wooden battens, can twist and warp if they are not kept flat. Keep this in mind when storing them. Battens should always be removed when the mainsail is furled. Keep a spare set of battens stored aboard should the others be broken or lost.

CENTERBOARD

Normal maintenance of the centerboard system should be as follows:

1. Clean and paint the centerboard as part of the routine annual maintenance of the hull. Check the pin location for cracks in the putty.
2. Check the attachment point of the pendant to the board. Inspect the eyesplice, thimble, clevis pin, and centerboard recess.
3. Check the block and tackle system inside the main cabin table base for wear and corrosion.

TEAK

Teak above deck on Cape Dory yachts has been sanded and oiled to a full golden hue before it leaves the assembly area. As it gets exposed to sunlight and drying conditions, the woods begin to take on a grey appearance that will eventually lead to surface deterioration of the wood. Teak which is ignored will eventually begin to split and grain will lift.

Contrary to what you may have heard, teak is not a miracle wood that is totally maintenance free. It is easy to maintain. There are a number of excellent teak cleaning and sealing preparations on the market. We suggest that you ask your sailing friends (who have teak you admire) for their suggestions. (Many excellent teak cleaning and sealing products are not available nationwide, so use the best available in your area.)

The teak may also be varnished; put three to six coats on initially; plan to apply another coat at midseason, and a final coat prior to winter lay up. Follow manufacturer's directions for the varnish which you purchase (use only quality marine varnish).

LEAKS

The fact of the matter about leaks is that they can occur and will occur due to the incredible strains transmitted into the hull, deck, and fittings while sailing. Although most leaks seem small at first, they should be addressed immediately to prevent larger problems occurring.

Unless the source of the leak is obvious, trace its origin by applying liberal amounts of water to isolated areas or individual pieces of hardware and then inspecting for a leak to appear.

DO NOT TURN A FASTENER UNLESS ABSOLUTELY NECESSARY.

Whenever you remove or turn a fastener in a bedded part, you break the seal that was made when the part was originally bedded in place. If a piece of hardware is leaking, take great care to only turn the nut when re-tightening and hold the fastener motionless. This way the bedding material will compress and possibly stop the leak rather than tearing the seal apart.

Areas particularly susceptible to leaking are the traveller bridge, genoa tracks, chainplates, stanchions, and companionway hatch.

The traveller bridge on some boats are fastened down to aluminum backing plates while latter models bolt up inside the headliner with plastic cap plugging the hole in the headliner. Leaks from the bridge base will appear either on the aluminum plate or plastic plug caps. The traveller bridge will need to be rebedded with Sikaflex 241. Rebed the seahood forward with Sikaflex 241 caulking.

A leak from the genoa tracks should first be attempted to be fixed by identifying which bolt is leaking and then tightening it down further. If the leak continues, the entire track must be lifted and rebedded.

Chainplates due to the amount of stress applied to them are particularly vulnerable to leaks developing. Water in the head area below the side decks on the counter or in the locker may indicate a leak has developed. Try first to tighten down the chainplate further by moving the nut and not the machine screw. Rebed with Sikaflex 241, if necessary.

Stanchions are also possible sources of leaking and should be treated similar to chainplates or other hardware for stopping leaks.

XVI. INTERIOR MAINTENANCE

Periodic cleaning is essential to keep the interior of your boat clean and bright. Choose sunny, breezy days for your boatkeeping chores as sun and fresh air are a great help in drying and airing interior cushions, etc. while you continue with chores below; they also contribute to your enthusiasm for the task!

WOOD SURFACES

Rubbing the wood periodically with a fine bronze wool when oiling will help produce a smooth satin surface. Many excellent teak oils are available as well as other household products such as "Liquid Gold." We recommend Matthew's oil and cleaning system for the highest quality finish on all wood surfaces.

Some finishes are in a wax base such as the Minwax products. Repeated use of this type product builds up a finish that produces a very smooth surface. Care should be exercised, however, when using these products as oiling or varnishing at a later date may not be possible due to the layer of wax that has accumulated.

Use caution when sanding teak veneered surfaces. The surfaces of teak veneered locker fronts or bulkheads have a thin surface layer of teak below which layers of less attractive plywood veneer cores lie. Once sanded through, repairs to veneered surfaces require professional attention.

Make sure that adequate ventilation is provided when it is called for by any cleaning or maintenance product's manufacturer.

CAUTION: SPONTANEOUS COMBUSTION CAN OCCUR IN OIL SOAKED RAGS. DO NOT LEAVE ANY ON BOARD.

CUSHIONS

Cloth covered interior cushions are made from several different materials depending on which color or style you selected. We, therefore, recommend that you either have the cushions dry cleaned or clean them with an upholstery shampoo of the spray foam type.

Vinyl interior cushions and cockpit cushions should be cleaned with a commercial vinyl upholstery cleaner. Follow the manufacturer's instructions regarding the use of these products. To prevent the growth of mildew beneath vinyl cabin cushions, elevate them when leaving the boat to allow air to circulate. Remove traps on boats so equipped so lockers will be aired.

If a substance has been spilled or dropped on a cushion, do not rub it out. This will only smear it around and in, lift it off or absorb it with a sponge or paper towel. Use a spot lifter after the major amount has been removed. Any liquid cleaner will embed the stain into the fabric further.

ICE BOX

The ice box on your Cape Dory is designed to drain water from melted ice through scuppers into the bilge. Because small food particles, juices from meats, etc. may also drain into the bilge, it is wise to use a strong bilge cleaner in the bilge as needed or every three to four weeks (depending on how frequently you are using the ice box). Follow the directions for use which accompany the product you select.

Another alternative is to fit a plastic gallon jug on the end of the ice box hose. Periodically dump the melted ice out into the sink.

Food items should not be left for long periods of time in a closed ice box without ice. Spoilage, odors, mold and mildew will result. Plan to clean out your ice box (both ice and food items) at the end of each sail or cruise when you are leaving the boat for an extended period of time. Remove the ice box cover to permit thorough drying. Clean up any spillage of food in the ice box, etc. to prevent blocking of the scuppers and drainage of this material into the bilge.

Clean the fiberglass interior surfaces of your ice box periodically with a sponge dampened with a water and bleach solution (this will help prevent mildew and odors in the ice box).

Cleaning your ice box with baking soda as well as leaving a box open inside during the season will cut down on any odor buildup.

PORTS AND HATCHES

The Spartan ports fitted on your yacht are made of bronze, tempered glass and stainless steel. A neoprene gasket bedded in a contact adhesive is used to seal the port.

The hinge pins and port knobs should receive a light periodic oiling to combat any build-up of salt spray that may accumulate. The glass may be cleaned with any non-abrasive household glass cleaner.

Optional port screens are available which snap into place on the outside of the port. Do not use strong solvents on the plastic portions of the screen.

Hatches made of Lexan material should not be cleaned with any solvent or abrasive cleaner. They should be rinsed with warm water only and cleaned with an acrylic cleaner. Other soaps and detergents will cause the lexan to film over losing some of its clear qualities.

SINKS

Stainless steel sinks may be cleaned with any stainless steel cleaner according to the manufacturer's instructions or with a non-abrasive cleaner and soft cloth or sponge.

HEAD

The plastic seat and vitreous china bowl of your head should be cleaned with a non-abrasive cleanser and sponge or soft cloth.

CURTAINS

Generally the curtains supplied have a content of 77% cotton and 23% acetate and, therefore, should be dry cleaned.

STOVES

The manufacturer of the stove includes an owner's manual with the appliance. Read it carefully and make sure that everyone who uses the stove understands its operation. Remember alcohol fires can be extinguished with water or Type B fire extinguishers. Kerosene fires must be extinguished by smothering or with Type B extinguishers.

The following precautions refer to all types of stoves. Refer to the owner's manual for specific instructions.

1. Never leave lighted stove unattended.
2. Never leave a stove while it is still hot. Remember alcohol can burn with an almost invisible flame.
3. Always release pressure in the fuel tank when leaving.
4. Close fuel valve (if applicable) in case of emergency.
5. Exercise caution when priming burners. Improper priming is one of the most common causes of galley fires.

GENERAL

Dirt, hair, etc. should not be washed into the bilge during any cleaning process as these may plug the bilge pump strainer and prevent it from functioning when needed. Use a dust pan to collect dirt, etc. when cleaning the cabin sole of your boat.

Raise covers of lockers when leaving the boat to permit adequate ventilation and prevent mildew should these contain moisture. Remove excess moisture which may have collected in lockers with a sponge.

XVII. WINTERIZING

Winterizing your yacht is a relatively simple procedure. The following instructions apply to a boat being dry stored. If you should decide to wet store your boat, be sure to take adequate precautions against water freezing in the engine and plumbing systems on your boat.

BLOCKING THE HULL

A good boat yard is, no doubt, expert at properly supporting the hull. Check to make sure that the weight of the hull is resting on the keel with the centerboard fully retracted. The purpose of cradle bulkheads

and poppets are to balance the boat in an upright position, not to bear the weight of the boat.

Before hoisting out, show the boat yard the profile of the hull so that they will know how to position the crane or straddle the hoist straps. The proper locations for the straps of a typical marine lift are just forward of the rudder heel bearing and forward of the keel on the hull as illustrated in the back of this owners manual.

BOTTOM

Upon haul out have the yard high pressure spray and scrape the hull's bottom to remove any growth that may have accumulated over the season. Do this at least once a year to ensure a clean, smooth sailing surface. The centerboard and trunk should be cleaned and the pennant pin integrity checked at the centerboard.

PROPELLER AND CUTLESS BEARING

These should be checked once the boat has been set in place for the winter. Add a silicone lubricant to the bearing to prevent it from "drying out" and check the prop for any damage it may have incurred. Replace the zinc Perry Nut, if necessary.

ENGINE

Follow the instructions in the owner's manual for the engine and read the section in this manual titled Diesel auxiliary for winterizing details.

Disconnect the engine cooling water intake to make sure that no water remains in the line. Reconnect line and secure hose clamps. Remove the drain plug in the muffler and drain.

FUEL TANKS

The best way to store a fuel tank is empty. Partially filled tanks invite condensation. Completely filled tanks leave you with old fuel in the spring and possible gum deposits. Much has been written lately on this subject and new products are being developed to prevent gum deposits. Keep informed and consult your dealer or shipyard for recommendations.

WATER SYSTEM

Pump tanks as dry as possible, then add a non-toxic water system winterizer that your local marine hardware store will recommend. (Caution: do not use antifreeze or other poisonous substances.) Pump this solution through the entire fresh water system, and drain.

HEAD

Follow manufacturer's directions closely. Remove any water to prevent from freezing. The holding tank should be empty when the yacht is laid up for the winter. If possible, flush the tank with a mixture of non-toxic antifreeze and water prior to hauling.

ELECTRICAL SYSTEM

Remove batteries from boat and store in a warm dry location off a cement or stone floor. They should be completely charged before storing or left on a trickle charge.

The rest of your electrical system requires little maintenance. If you wish, each bulb can be removed and the light fixtures given a spray of water dispersant such as "WD-40," "CRC," or similar products. The main switch and fuse panel can also be treated this way to minimize corrosion.

SCUPPERS AND SEACOCKS

Open and drain all seacocks once the hull has been set in place. The barrel itself may be removed, inspected, re-lubricated, and assembled at this time. Seacocks should be left closed while out of water during winter storage except cockpit scupper seacocks which must be left open.

ICE BOX

Remove all food from the ice box and wash out thoroughly with warm water and detergent. Rinse well. Remaining odors, if any, may be eliminated with baking soda and water. All water will drain to bilge area and help eliminate odors there also. Leave ice box top open for ventilation. Store an open box of baking soda in the ice box during winter lay up.

BILGE

Pump the entire bilge dry and clean out any debris. Drain the bilge hoses and pump(s) to prevent freeze-up.

STOVE

Clean stove thoroughly including burners. Release pressure in fuel tank and leave tank empty.

COVERING

It is far better to store a boat under cover than to leave it open to the elements. The teak trim will fare far better during the winter and the boat will not be subject to the pressure of freezing water, a common cause of gelcoat stress cracks. If your boat cover is durable, open a couple of ports to allow air to circulate below decks.

MAST AND BOOM

Tie off all shrouds and halyards preferably marking each for easy identification when the mast is re-stepped.

Check for abrasion and wear. Lubricate sheaves after a thorough wash down with fresh water.

VENDOR PARTS LIST

In the interest of faster and more efficient service, Cape Dory has developed a list of the more important equipment and manufacturers. We produced this list so that the Cape Dory owner will be able to go directly to the original vendor for replacement parts, but we still want you to feel free to call us here at the factory for any additional information.

ITEM DESCRIPTION	MANUFACTURERS PART #	VENDOR
BLOCKS:		
Genoa Blocks	07-83	Schaefer Marine
Boom Block	05-13	Schaefer Marine
Boom Block	05-05	Schaefer Marine
Traveller Block	05-43	Schaefer Marine
CB Tackle Blocks	303-33	Schaefer Marine
BOTTOM PAINT:		
Antifouling Brown	Unipoxy	Pettit
Boot Top Dado Dark Brown	246	Interlux
Unipoxy Primer		Petit
ELECTRICAL:		
Battery - 12 volts - 75 amps	5124M	Bay State Battery
Dome Lights (bulb 12V15CP)	10-1252	Bass Products
Single Swivel (bulb GE1142)	10-2162	Bass Products
Double Swivel (bulb GE1142)	10-1872	Bass Products
8 watt florescent (GEFT5-CW)	10-1872	Bass Products
Panel		Lorco Marine
Port & Starboard Light		Ahlemann & Schlatter
Stern Light (bulb 12V10W)	11790	Gem
Mast Light (GE212 & 12V6W)		Spartan Marine
ENGINE:		
Westerbeke W-13		
Zinc (2)	11885	Westerbeke
Oil Filter Element	30220	Westerbeke
Fuel Filter Element	30200	Westerbeke
O Ring	30705	Westerbeke
O Ring	30201	Westerbeke
Alternator Belt	30376	Westerbeke
Fuel Filter Element	30548	Westerbeke
Electric Fuel Pump		
Sea Water Pump Cover Gasket	24826	Westerbeke
Sea Water Pump Impellor	11764	Westerbeke
PORTS & HATCHES:		
Medium Hatch	139-medium	Bomar, Inc.
Bronze Oval Ports	P-560	Spartan Marine
HEAD:		
Marine Head	HE-HTP	Gross Mechanical

HOT WATER HEATER:		
Raritan	6E	Raritan Engineering
Spare Parts:		
Heating Element	WH1A	Raritan Engineering
Safety Valve	WH3	Raritan Engineering
Heat Exchanger	HE	Raritan Engineering
Thermostat	WH2	Raritan Engineering
PEDESTAL:		
5" Pedestal	335	Edson Corp.
Chain Assembly	775	Edson Corp.
4" Upright Single Sheave	620	Edson Corp.
4" Swivel Idler	711	Edson Corp.
8" Quadrant (CD-30)	614	Edson Corp.
8" Offset Quadrant (CD-27/28)	677	Edson Corp.
#1 Wire Take-up Eye	618	Edson Corp.
3/16 Wire Rope Clamp	665	Edson Corp.
1-1/8 Self Aligning Bearing	629A	Edson Corp.
Size 45 Shift and Throttle	816	Edson Corp.
Size 456 Brake	6897	Edson Corp.
Size 45 Guard	662	Edson Corp.
22" Wheel	Various	
PUMPS:		
Manual Bilge Pump	Whale Gusher 8	Imtra
Pressure Water Pump	36950	Parr Jabsco
Galley Foot Pump	GP-0507	Imtra
Head Foot Pump	GP-46A8	Imtra
Counter Top Pump	37220-0010	Parr Jabsco
Electric Sump Pump	Rule 750	C.E. Beckman
Sump Pump Switch	Rule 49	C.E. Beckman
or		
Electric Sump Pump	36251-0000	Parr Jabsco
Sump Pump Switch	44960-0002	Parr Jabsco
TRACKS:		
3/4" T-Track (TY-22)		Spartan Marine
1" T-Track (25D/28/30)		Spartan Marine
Traveller Bridge (28/30)	1159	Nicro Fico
SHIFT & TRHOTTLE CABLES:		
Teleflex Dual Lever	402004	Teleflex CH6000a
3300 CC 6' Cable	A5797/06	402051
3300 CC 8' Cable a5797/08	402052	
DECK HARDWARE:		
1. Bow Rail	106026	Ocean Engineering C-270
2. Stem Head	104041	Spartan Marine S-743
3. Anchor Locker Cover Hinge	109011	Spartan H-414
4. Anchor Locker Cover Hasp	109040	ABI 2016 BR
5. Bow and Stern Cleat	102004	Spartan Marine C-207
6. Stanchion 24"	106112	Ocean Engineering
7. Anchor Rode Dead End	105014	Schaefer Marine 78-22
8. Stern Chock	103001	Spartan Marine C188

9. Fuel Fill	405032	Spartan Marine F-302-PB
10. Forward & Aft Lower Chainplate	104010	Spartan Marine C182
11. Opt. Outboard Track		Spartan Marine T-714-02C
12. Seat Hinge	109015	Spartan Marine H400
13. Seat Locker Hasp	109019	Spartan Marine H416
14. CB Pennant Ext. Block	505116	Ocean M
15. Water Fill Plate	302012	Spartan Marine F-305-PB
16. Hatch	109013	Bomar 139 Med. Tan
17. Inboard Track	110004	Spartan Marine T-714-08C
18. Track End Stops	110021	Spartan Marine S652
19. Genoa Sheeting Block	101010	Schaefer Marine 07-83
20. Cockpit Scupper	306005	Spartan Marine D251
21. Bilge Pump	301009	Whale GP 8-BP9064
22. Mainsheet Block	101003	Schaefer Marine SK2846
23. Double Sheave Cheek Block	101020	Schaefer Marine 05-80
24. Engine Room Vent	111008	Nicro Fico 10883C
25. Coaming Cleat B/UP	550003	Spartan Marine B202
26. Mainsheet Winch	112005	Lewmar 6 BZ
27. Cam Cleat	102010	Schaefer 70-41
28. Winch Base	112100	Spartan Marine W856
29. Coaming Cleat	102008	Spartan Marine C191
30. Cowl Vent	111009	Nicro Fico 10923C
31. Bow Light	502018	Aqua Signal Series 25
32. Port	107022	Spartan Marine P560
33. MastStep	107022	Spartan Marine SP-770
34. Dorade Box	510040	Cape Dory
35. Hand Rail	510008	OBSW S-302-25D
36. Traveller Set	110703	Nicro Fico 1159-3
37. Tiller	507090	Spartan Marine T772
38. Winch	112015	Lewmar 16 BZ
39. Tiller Strap	106028	Spartan Marine T-705-SC
40. Stern Rail	111008	Ocean Engineering C-270
41. Stern Light	502017	Aqua Signal Series 25
42. Upper & Backstay C/P	104011	Spartan Marine C181
FUEL SYSTEM:		
Fuel Tank 15 Gal.	405016	Florida Marine
Deck Fill Plate	405033	Spartan Marine F-302-PB
Fuel Filter - Fram	405020	Schuster FCS-1136
Vent	405028	Spartan Marine V-100-PB
WASTE AND DISCHARGE SYSTEM:		
Holding Tank 24 Gal.	303005	Kracor 2-6256
Marine Head	303002	Gross Mechanical HE-HTP
Waste Plate	303006	Spartan Marine P575
Vent	405028	Spartan Marine V-100-PB
Intake Seacock 3/4"	304376	Spartan Marine S636
1-1/2" Tee PVC	301009	Imtra BP9064

Discharge Pump	301009	Imtra BP9064
Vented Loop	303007	Scot SMF-15-180V
Discharge Sea cock 1-1/2"	304450	Spartan Marine S637
Sink	305009	Polar Ware
Sink Drain Seacock 3/4"	304376	Spartan Marine S636
Galley Sink	305007	Polar Ware 173-1
Sink Drain Trap Assy.	305004	Kevco 32890
Sink Drain Trap Assy.	305004	Kevco 32890
Filter	301002	Beckson STV-1 1/2
Bilge Pump	301009	Imtra BP9064
1-1/2 Bronze Thru hull	304153	North & Judd 8569-1 1/2
FRESH WATER SYSTEM:		
Fresh Water Pump	302004	Jabsco 37220-001
Water Tank 46 ga.	302035	Kracor 1-5141
Fill Plate Water	302012	Spartan Marine F-305- PB
Fresh Water Filter	302005	Jabsco 36400-0010
Water Heater	302015	Raritan R-6-E
Delta Faucet	302009	R & L 101
Shower Assy.	302014	Bristol 21-T-73
Pressure Faucet Head	302013	Bristol 23-9959-5
Pressure Manifold	302022	Cape Dory - 2 valve
Pressure Pump	302021	Shurflo 220-213-34

VENDOR ADDRESSES	
Ahlemann & Schlatter/ Browning Marine	P.O. Box 806 St. Charles, IL 60174
Bass Products	P.O. Box 901 Marblehead, MA 01945
Bay State Battery	70 Shawmut Road Canton, MA 02021
S.E. Beckman	11-35 Commercial Street New Bedford, MA 02740
Bomar	Box 314, South West Street Charlestown, MA 03603
DiPetro Kay Corp.	914 Cromwell Avenue Rocky Hill, CT 06067
Edson Corp.	460 Industrial Park Road New Bedford, MA 02745
Essex Machine Works	West Avenue Essex, CT 06426
Gem Products	369 Blanding Boulevard Orange Park, FL 32073
Gloucester Paints	P.O. Box 860 Gloucester, MA 01930
Gross Mechanical Lab.	7240 Standard Drive Hanover, MD 21076
Imtra	151 Mystic Avenue Medford, MA 02155
International Paint Co.	Morris & Elmwood Avenue Union, NJ 07083
Lewmar Marine	23 Broad Common Road Bristol, RI 02809
Lorco Marine Electric	715 Perimeter Road Manchester, NH 03032
Mack Boring & Parts Co.	Route 22 West, Engine City Union, NJ 07083
Merriman-Holbrook	301 River Street Grand River, OH 44045
Nicro Fico	2065 West Avenue 140 th San Leandro, CA 94577
Northwest Controls	Vernfield Village Harleysville, PA 19438
Parr Jabsco Products	1485 Dole Way Costa Mesa, CA 92626
Raritan Engineering Co.	1025 North High Street Milville, NJ 08332
Rule Industries	Cape Ann Industrial Park Gloucester, MA 01930
Schaefer Marine Products	Industrial Park New Bedford, MA 02745
Spartan Marine Products	160 Middleboro Avenue East Taunton, MA 02718
Westerbeke	P.O. Box 4137 Boston, MA 02211

Cape Dory 270

Technical Information

LOA	27' 3"
LWL	20' 9"
Beam	9' 5"
Draft	3' 0" Board Up 7' 0" Board Down
Displacement	8380
Ballast	3250
SA	398 100% Fore Triangle
I	38' 0"
P	32' 4"
J	11' 7"
E	11" 0"
Main Luff Slug Size	B8 1" Flat
Main Foot Slug Size	B6 3/4" Flat
Main Tack Cut Back	2"

Standing & Running Rigging

Forestay (W)	1/4 - 38' 10"
Backstay (W)	1/4 - 40' 3"
Uppers (W)	7/32 - 37' 1"
Forward Lowers (W)	3/16 - 19' 0"
Aft Lowers (W)	3/16 - 19' 2"
Main Halyard (P)	7/16 - 75'
Jib Halyard (P)	7/16 - 80'
Main Sheet (D)	7/16 - 37'
Jib Sheet (D)	7/16 - 33'
Genoa Sheet (D)	7/16 - 40'
Topping Lift (D)	1/4 - 19'
Clew Reef #1 (D)	3/8 - 22'
Clew Reef #2 (D)	3/8 - 28'
Spinnaker Halyard (D)	7/16 - 90'
Spinnaker Sheet (D)	7/16 - 40'
CB Tackle (D)	3/8 - 13'
CB Pennant (D)	1/4 - 7'

W - Wire

P - Prestretched Dacron Rope

D - Dacron Braided Rope

1. SAIL PLAN



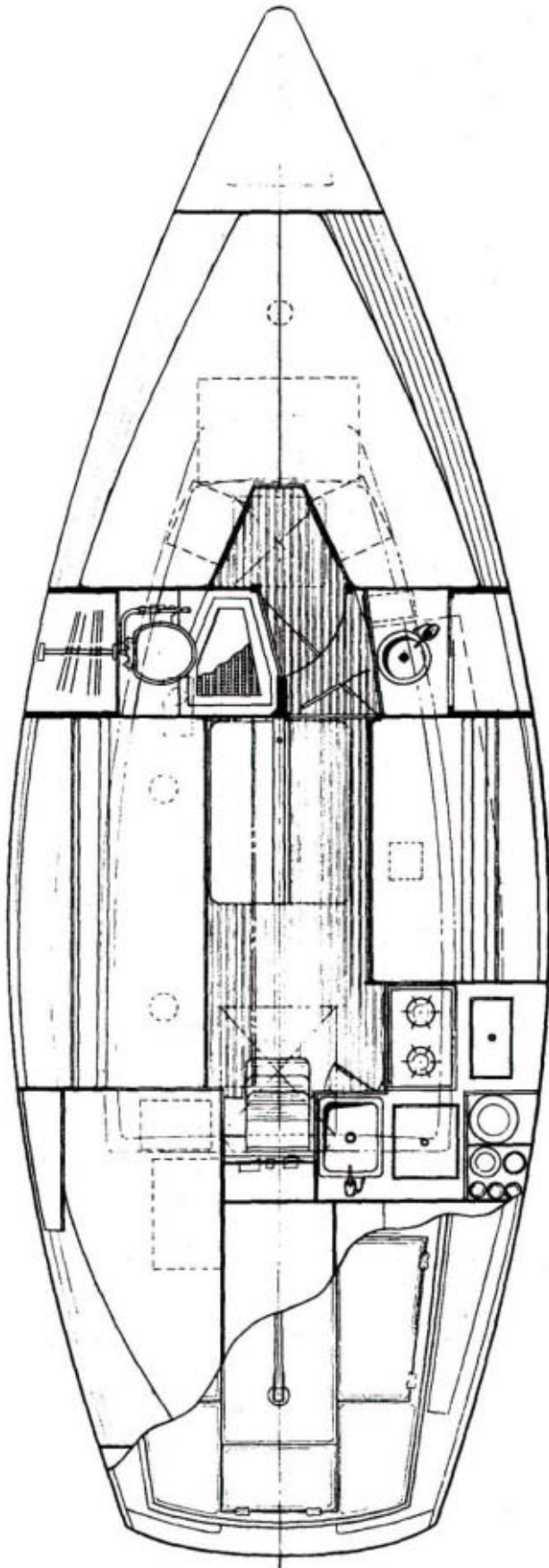

2. ARRANGEMENT

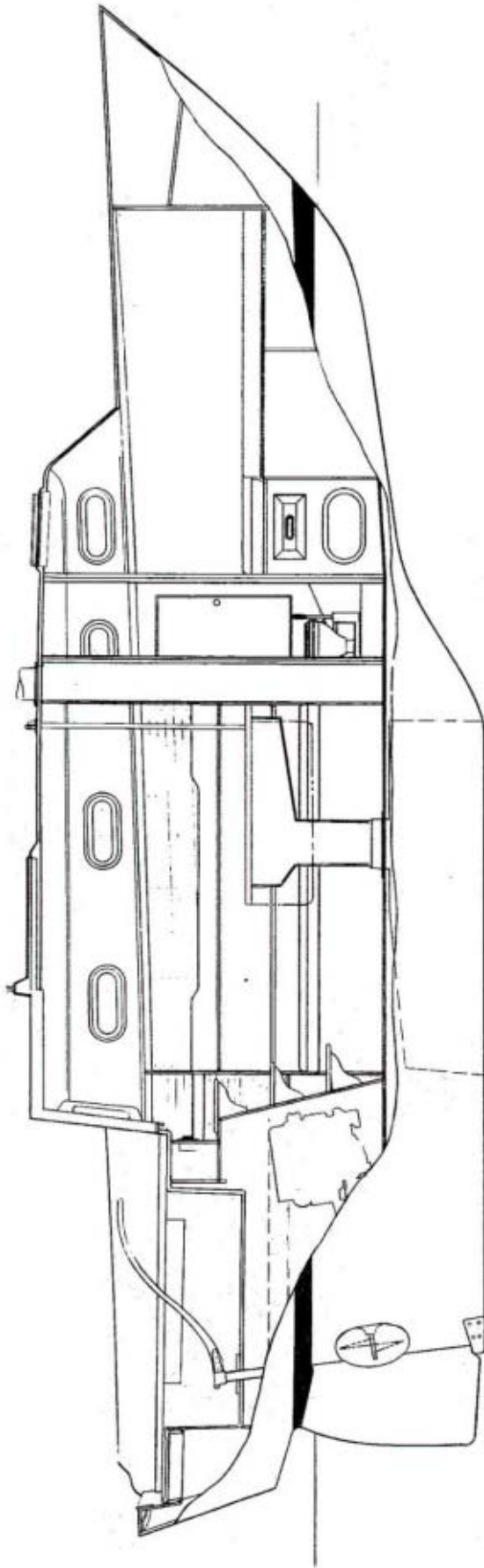

3. STARBOARD ELEVATION

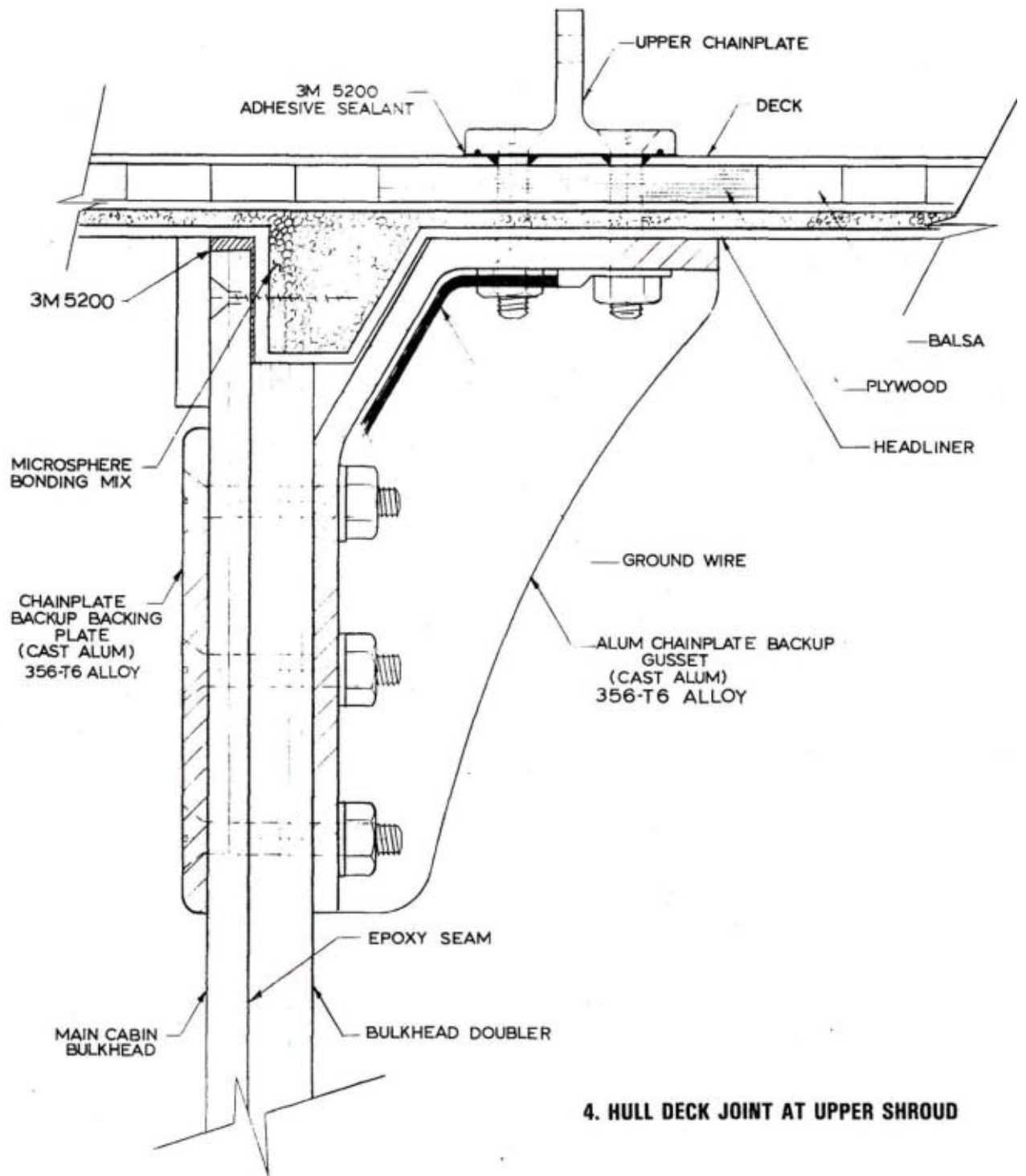

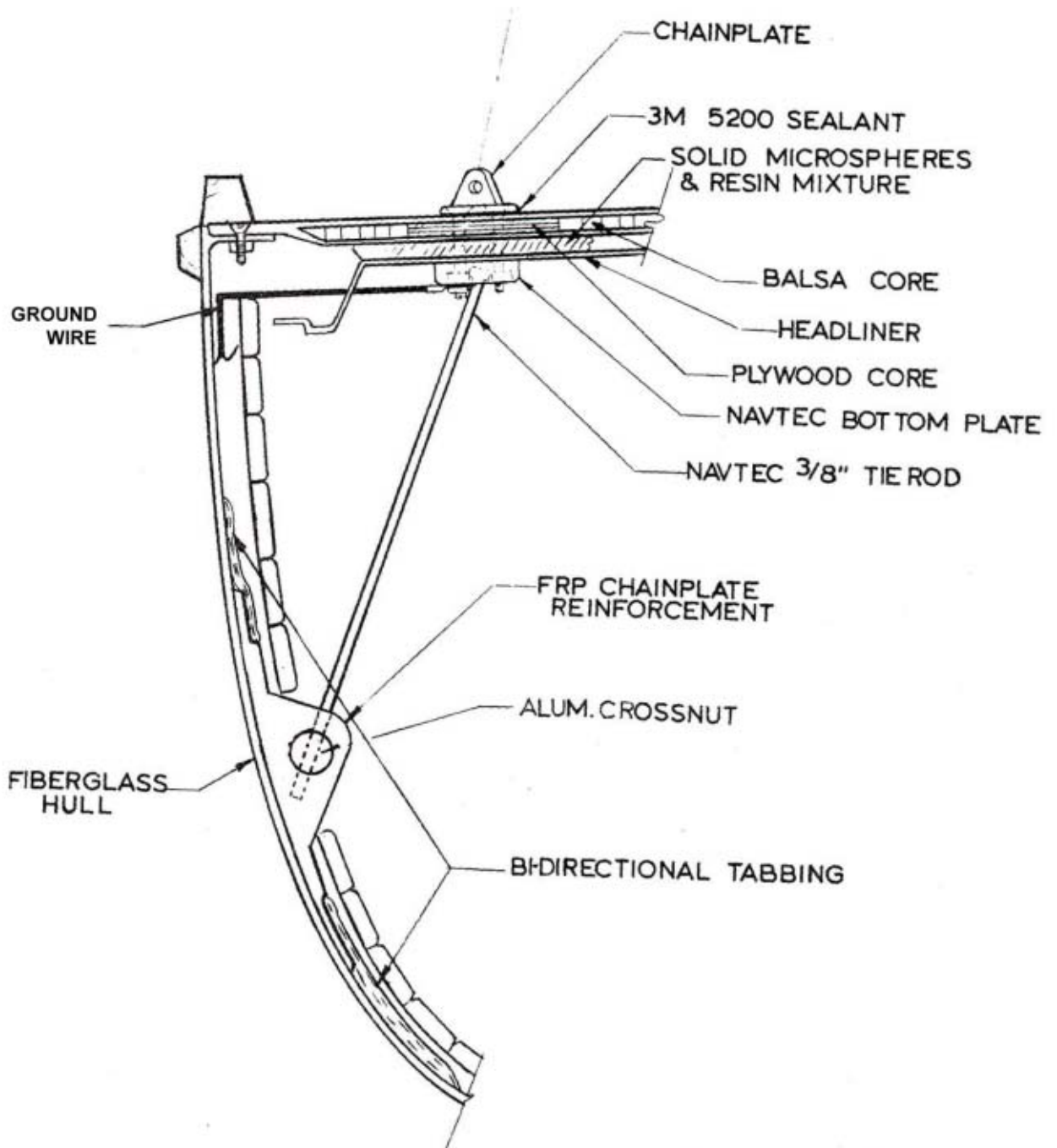

5. HULL DECK JOINT AT LOWER SHROUD

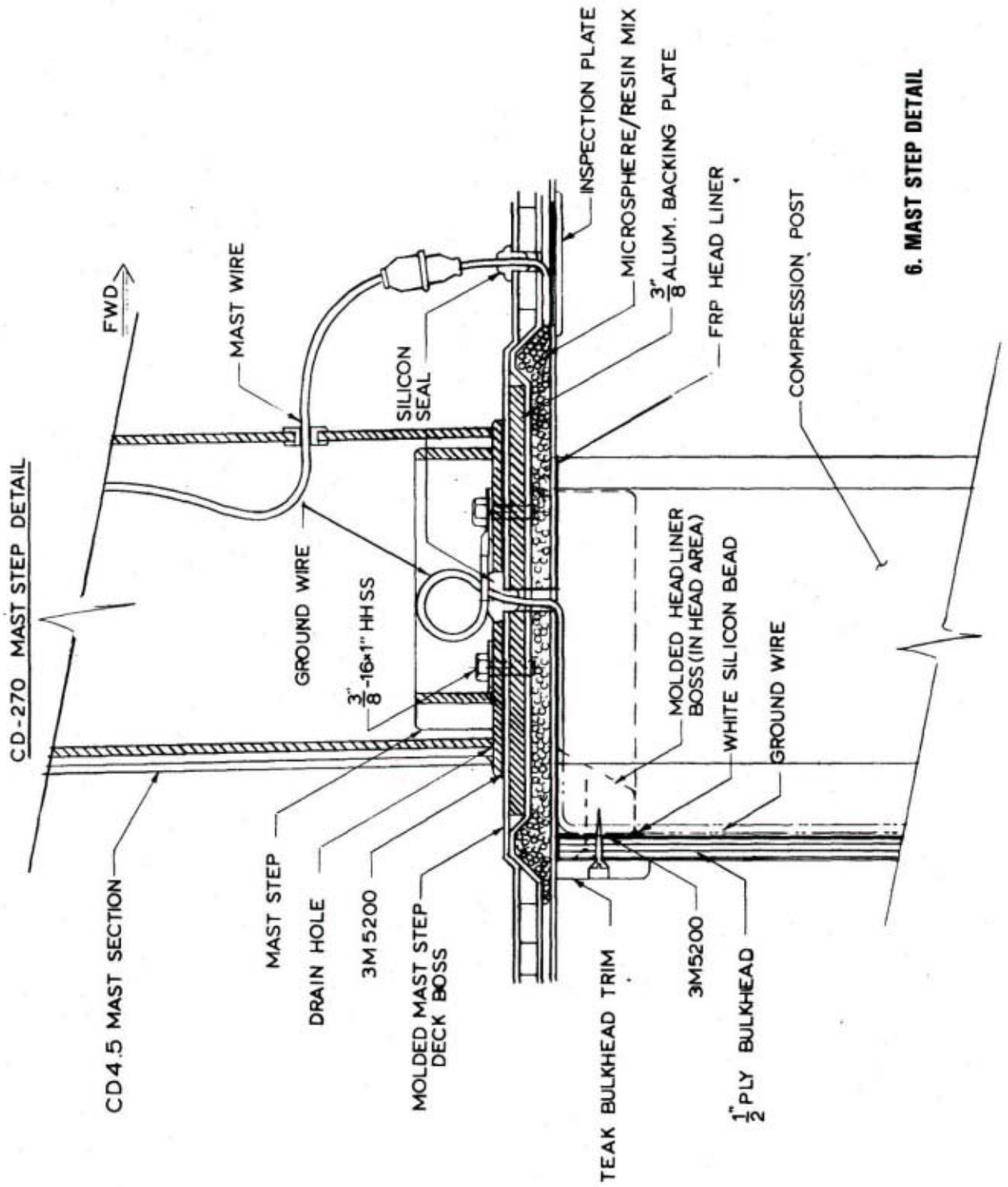

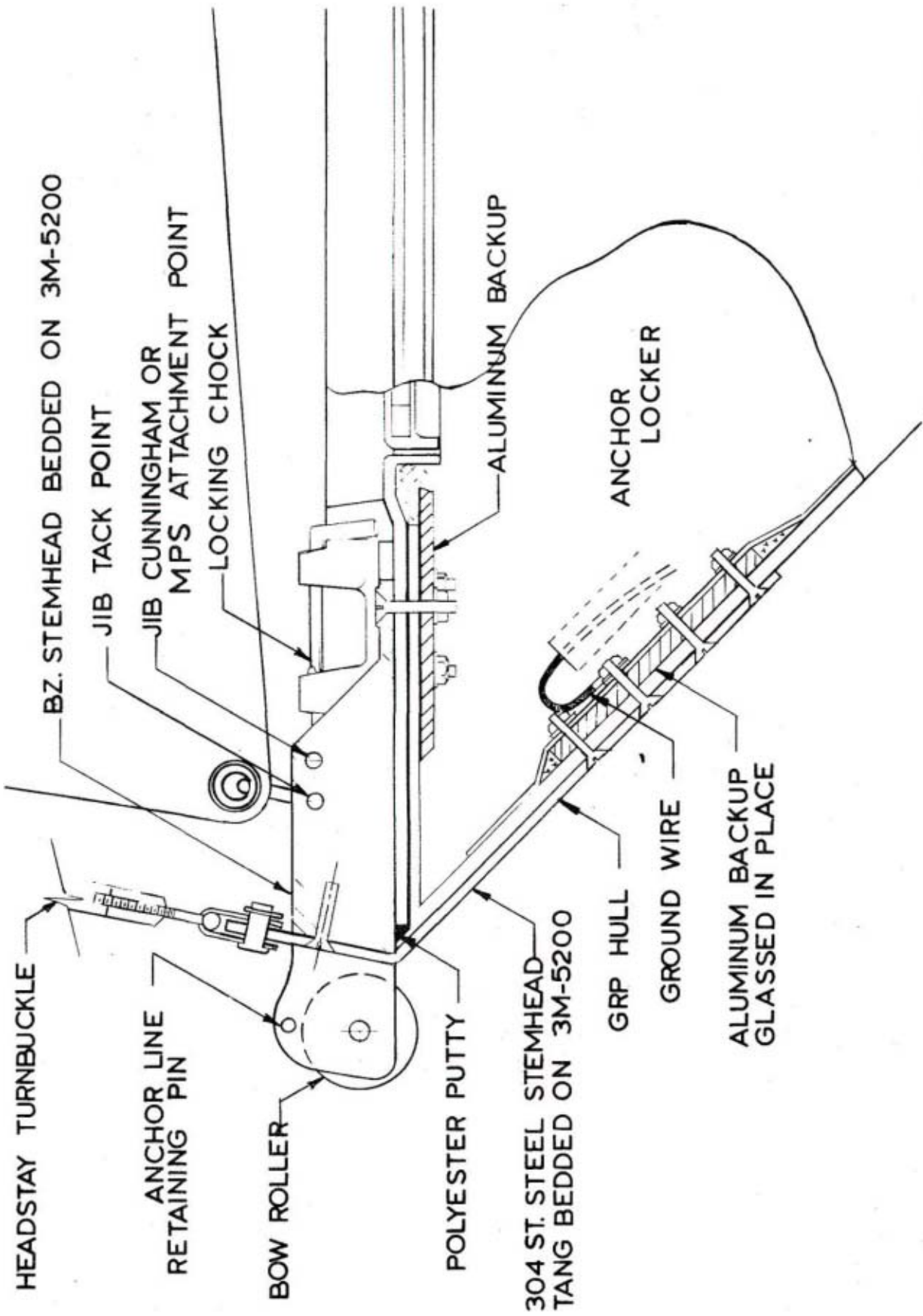

7. STEMHEAD DETAIL

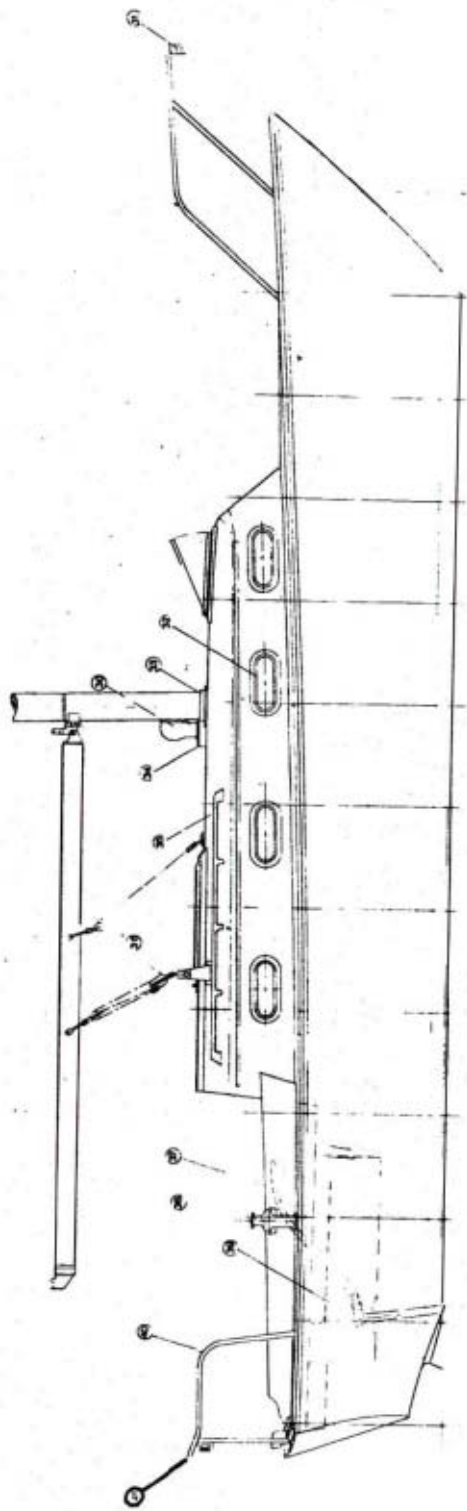

8. DECK HARDWARE LAYOUT

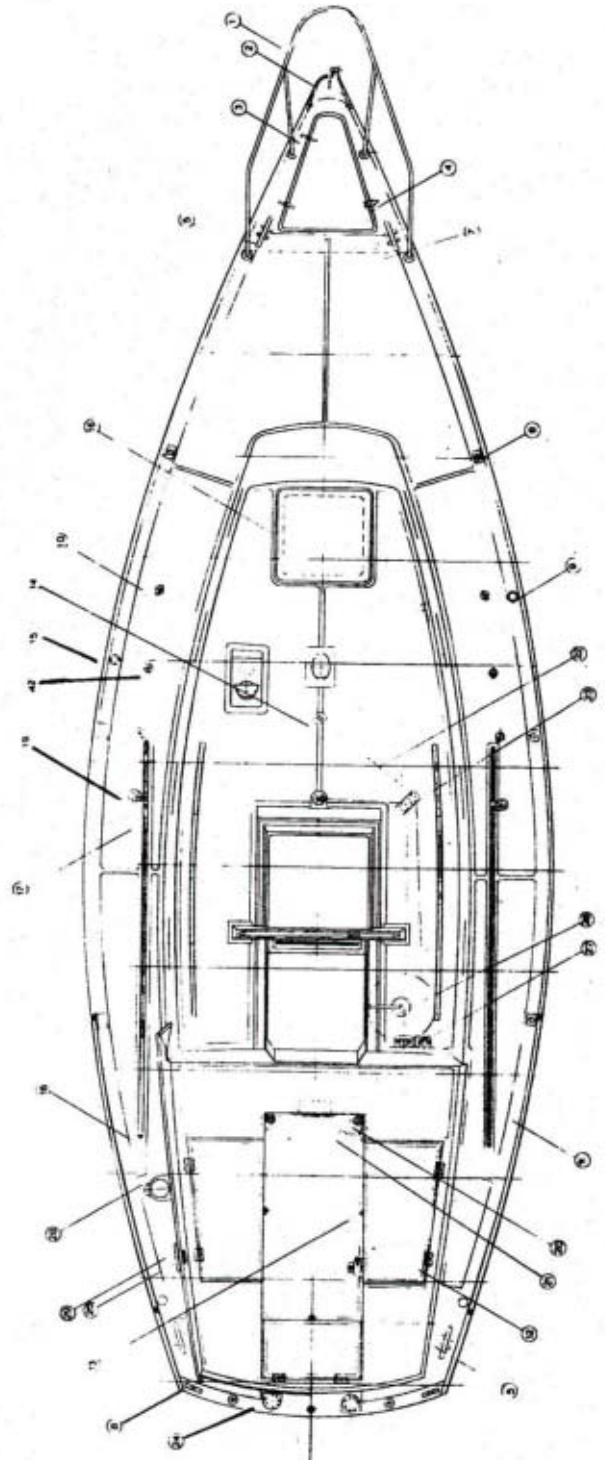

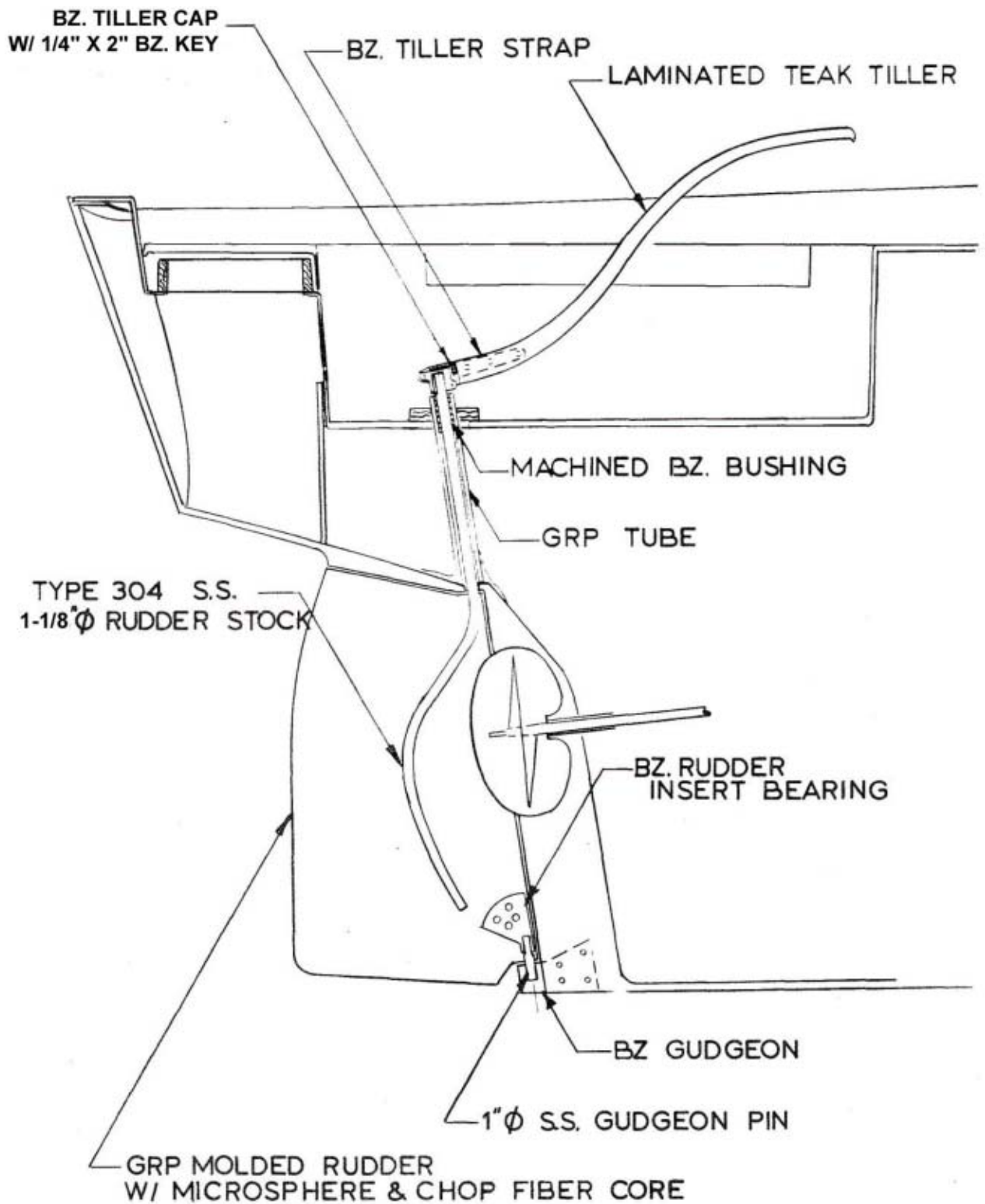

9. STEERING SYSTEM - TILLER

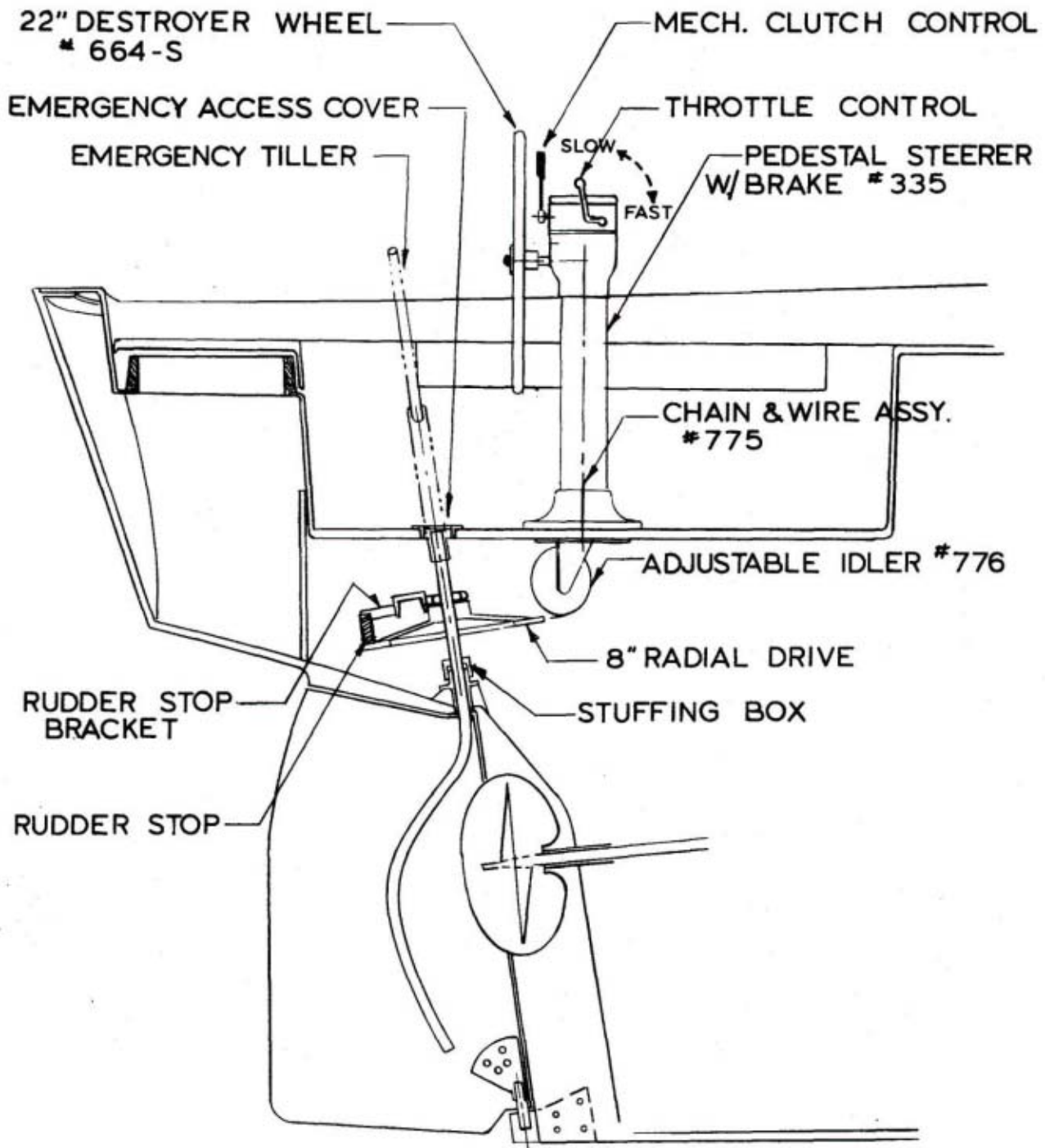

10. STEERING SYSTEM - WHEEL

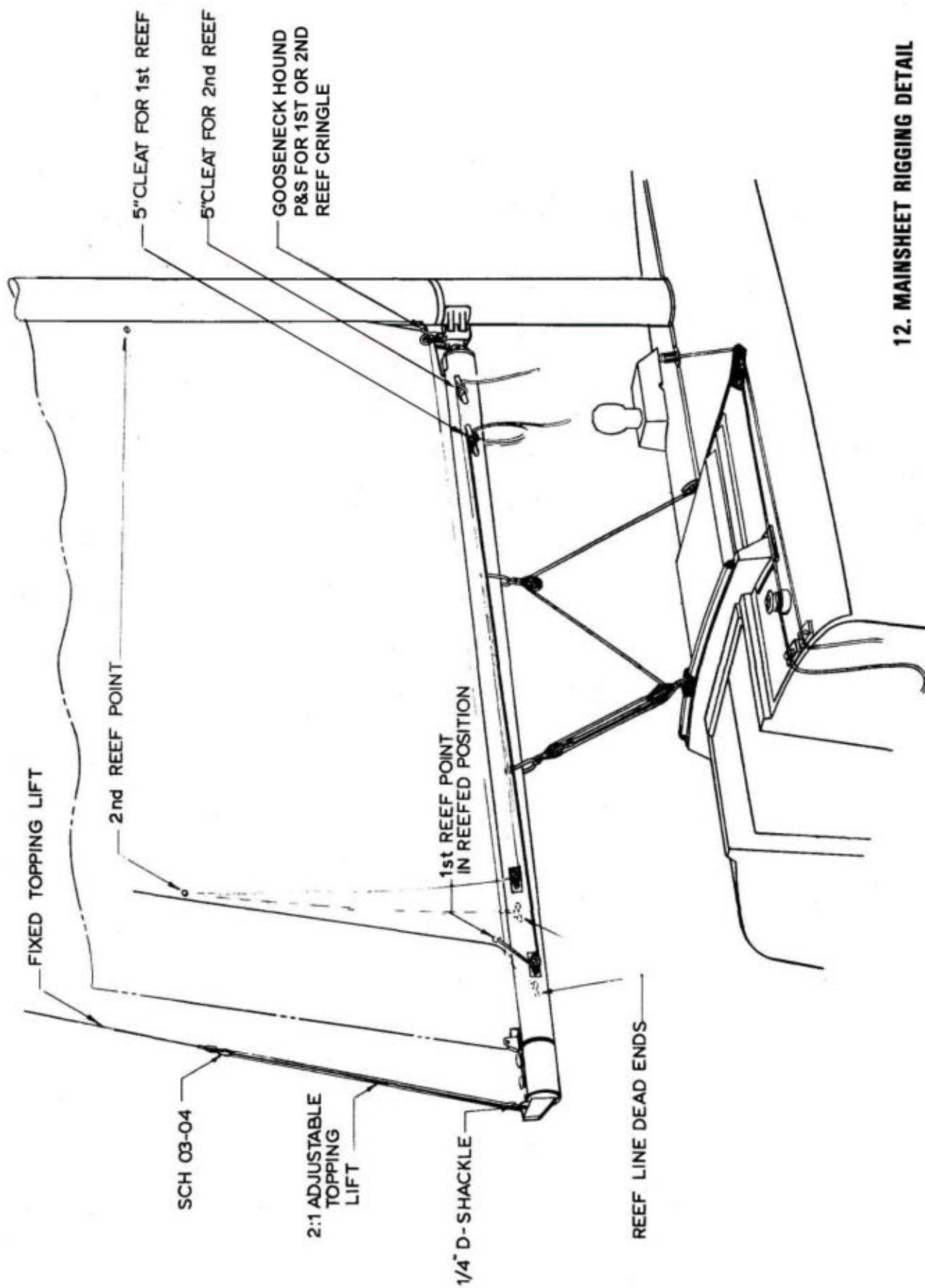

12. MAINSHEET RIGGING DETAIL

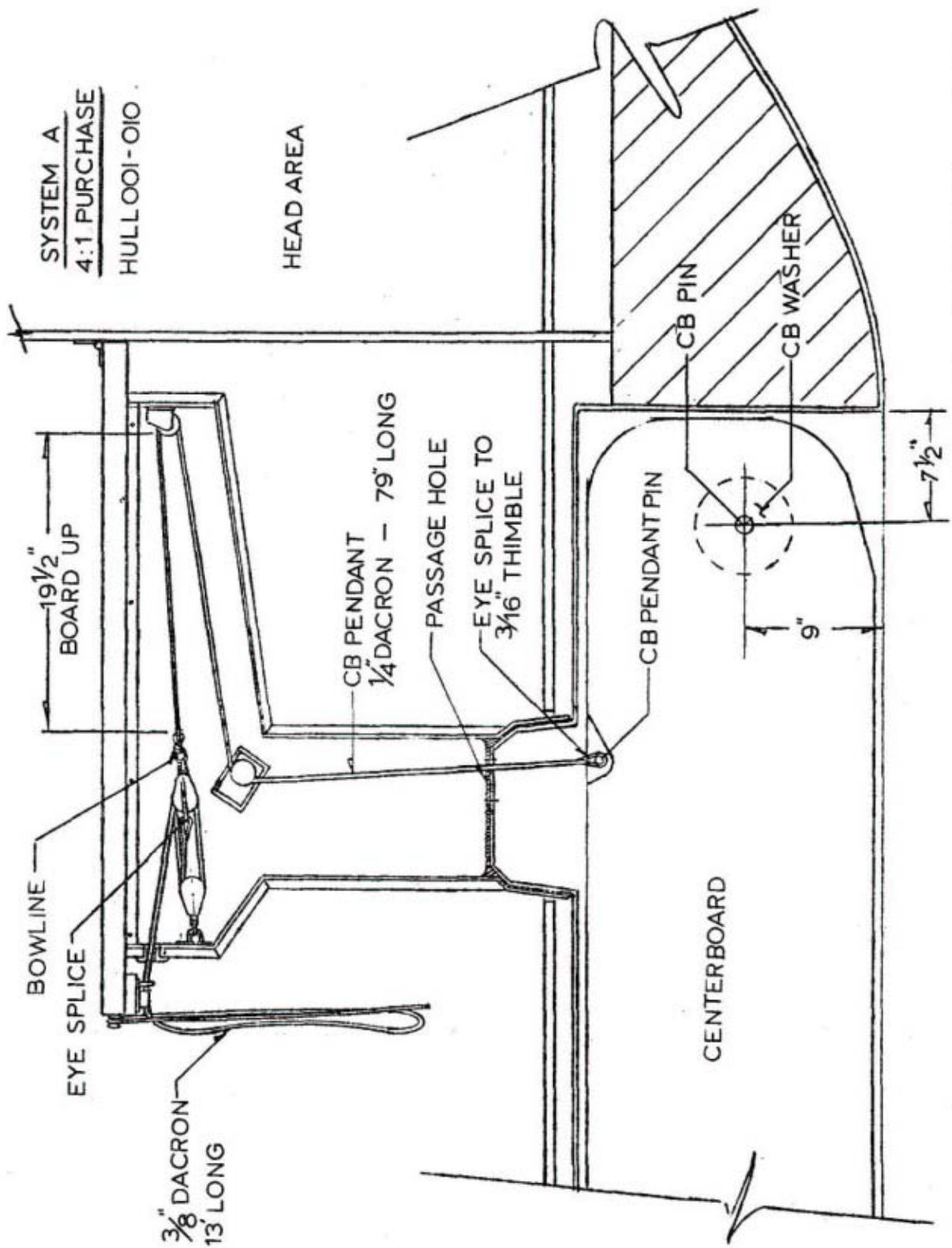

13. CENTERBOARD - SYSTEM A

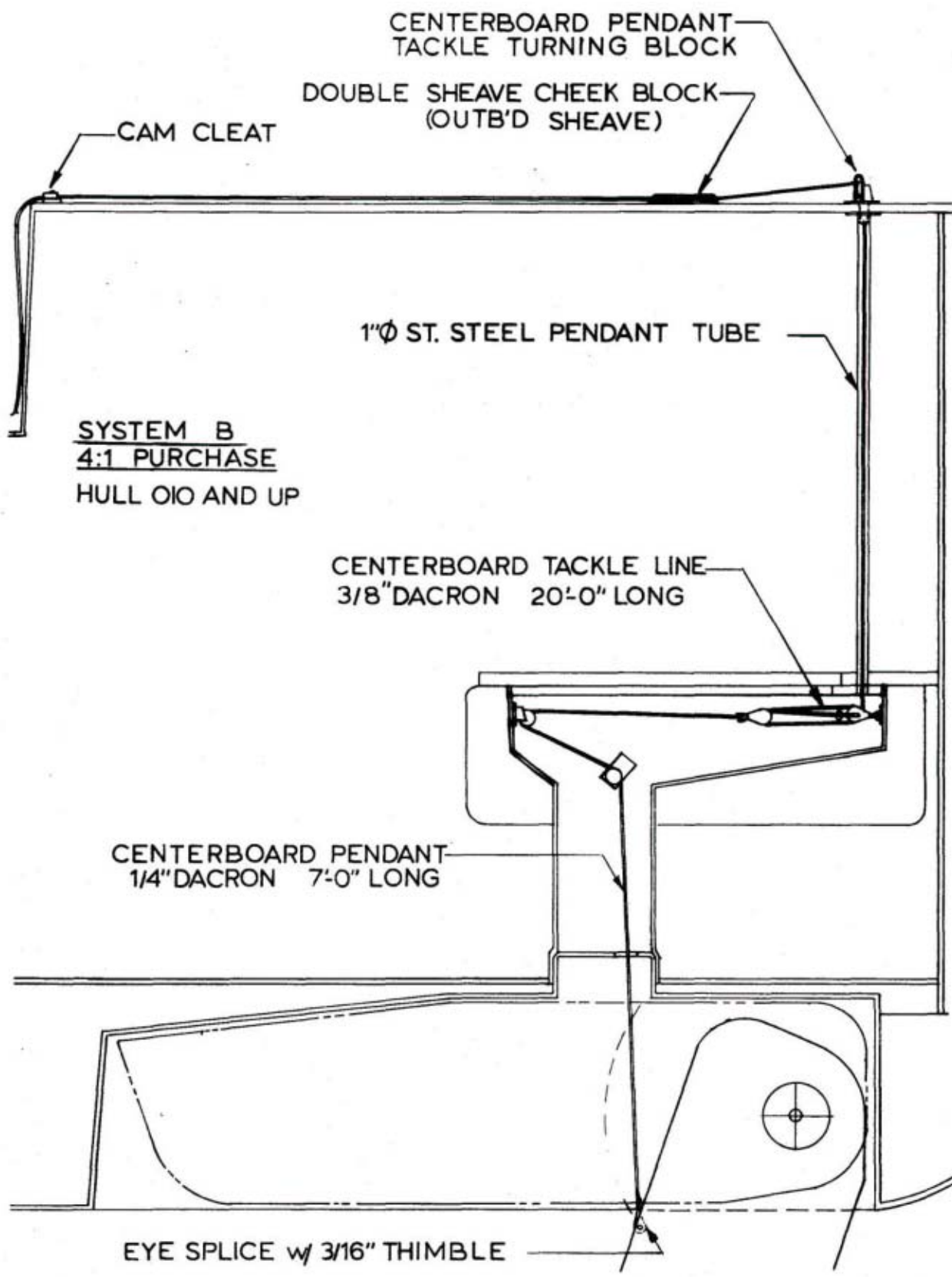

SYSTEM B
4:1 PURCHASE
 HULL OIO AND UP

CENTERBOARD TACKLE LINE
 3/8" DACRON 20'-0" LONG

CENTERBOARD PENDANT
 1/4" DACRON 7'-0" LONG

EYE SPLICE w/ 3/16" THIMBLE

14. CENTERBOARD - SYSTEM B

SEA VALVE

SUPERFLEX HOSE
CLAMPED IN PLACE WITH
LIQUID GASKET SEALER

DOUBLE S.S. CLAMP

CLOSED

OPEN

BRASS
1/4"-20 FHMS

FRP HULL

BRONZE THRU HULL
THREADS SEAL & BED ON
BLACK POLYSULFIDED
PLYWOOD BACKING BLOCK
BEDDED ON 3M5200

SPARTAN BRONZE SEACOCK
BEDDED ON BLACK POLYSULFIDED

CLOSED

8 COPPER WIRE
TO GROUND PLATE

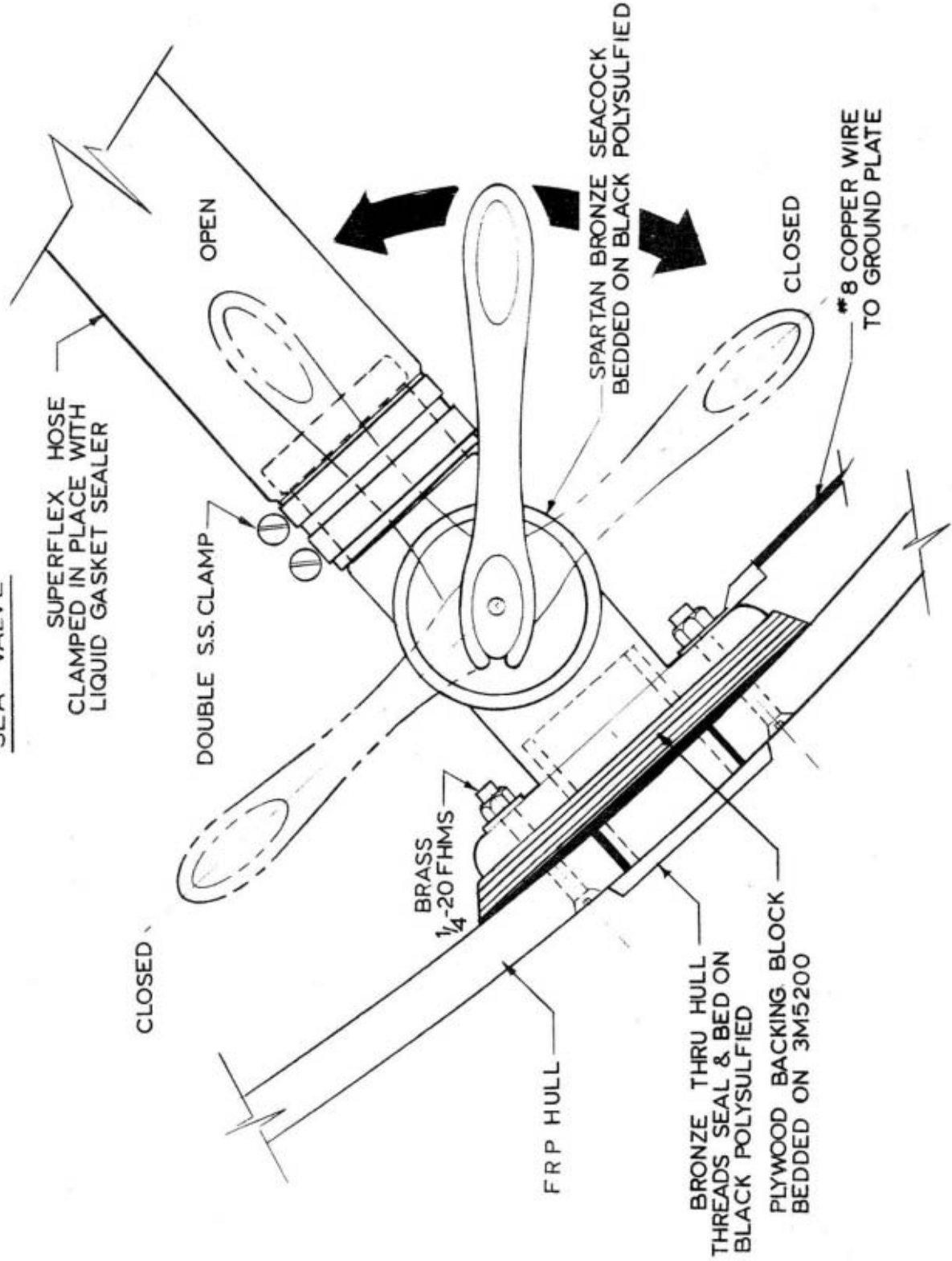

15. SEACOCK DETAIL

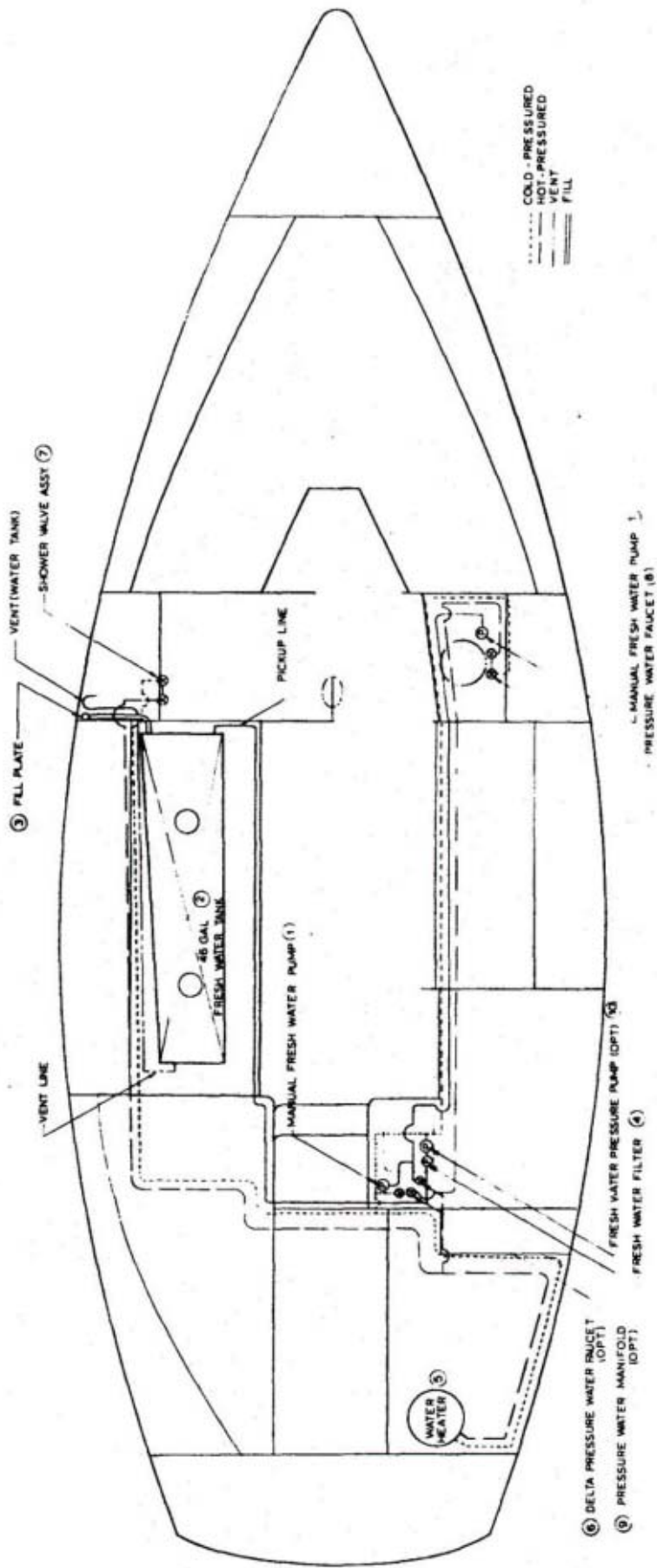

16A. FRESH WATER SYSTEM

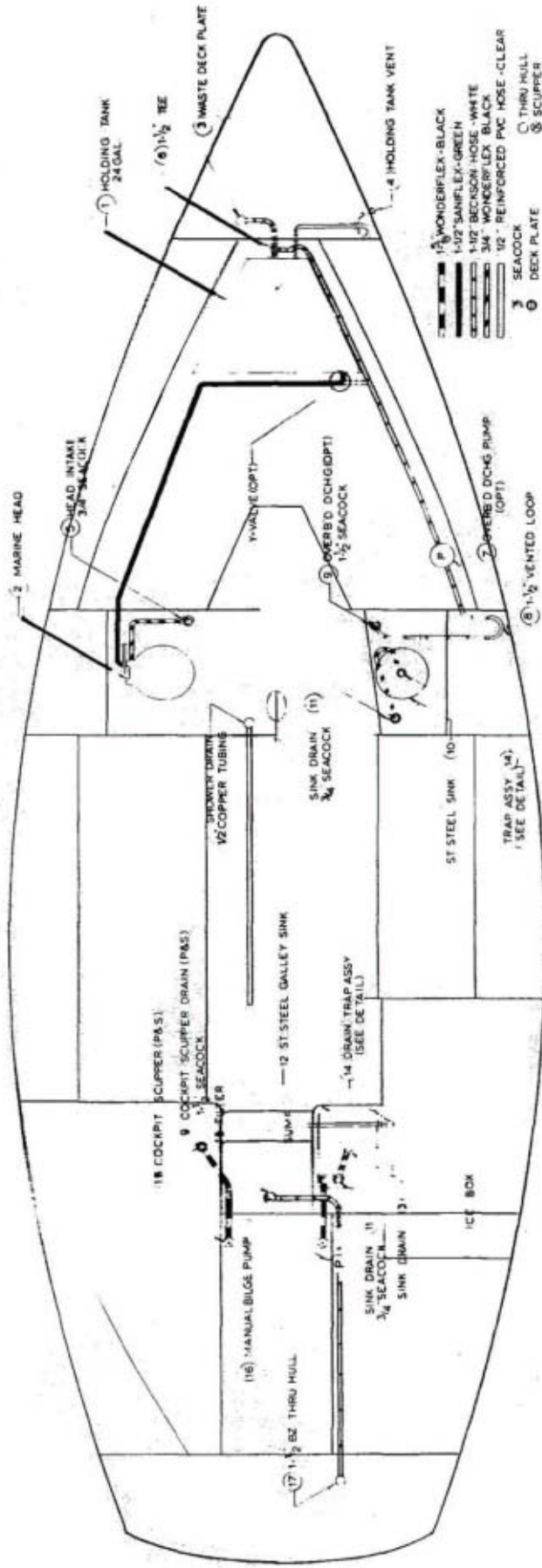

16B. WASTE & DISCHARGE SYSTEM

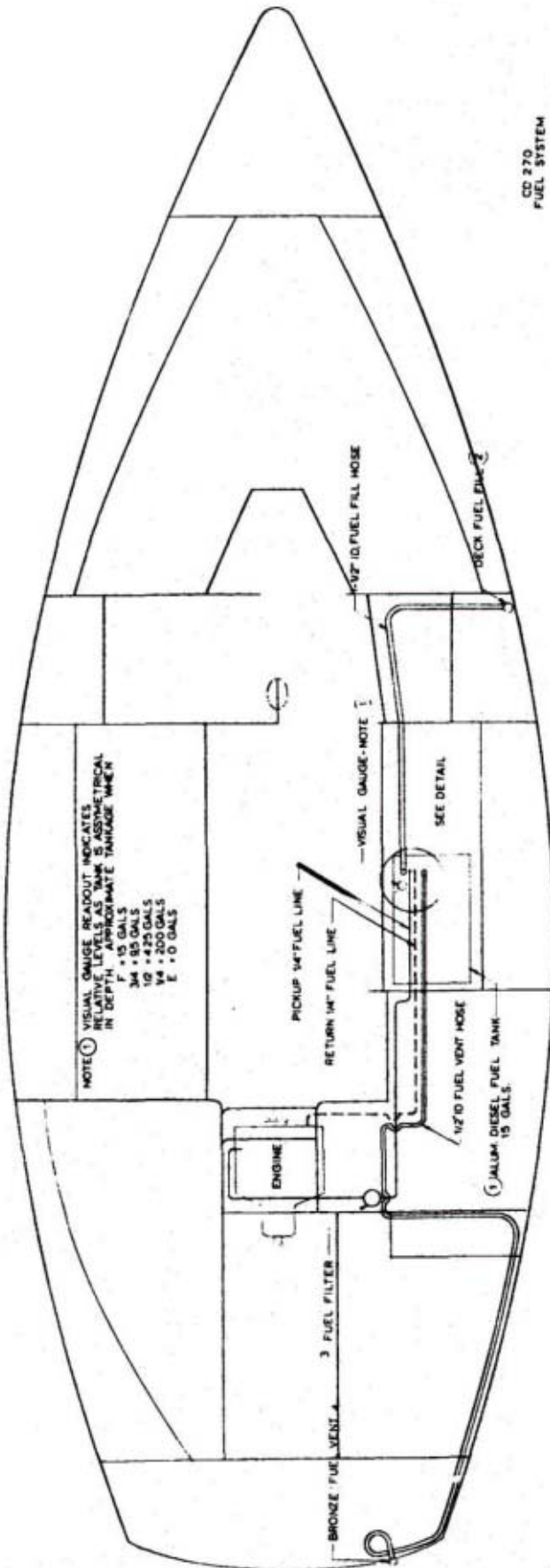

CD 270
FUEL SYSTEM

17A. FUEL SYSTEM

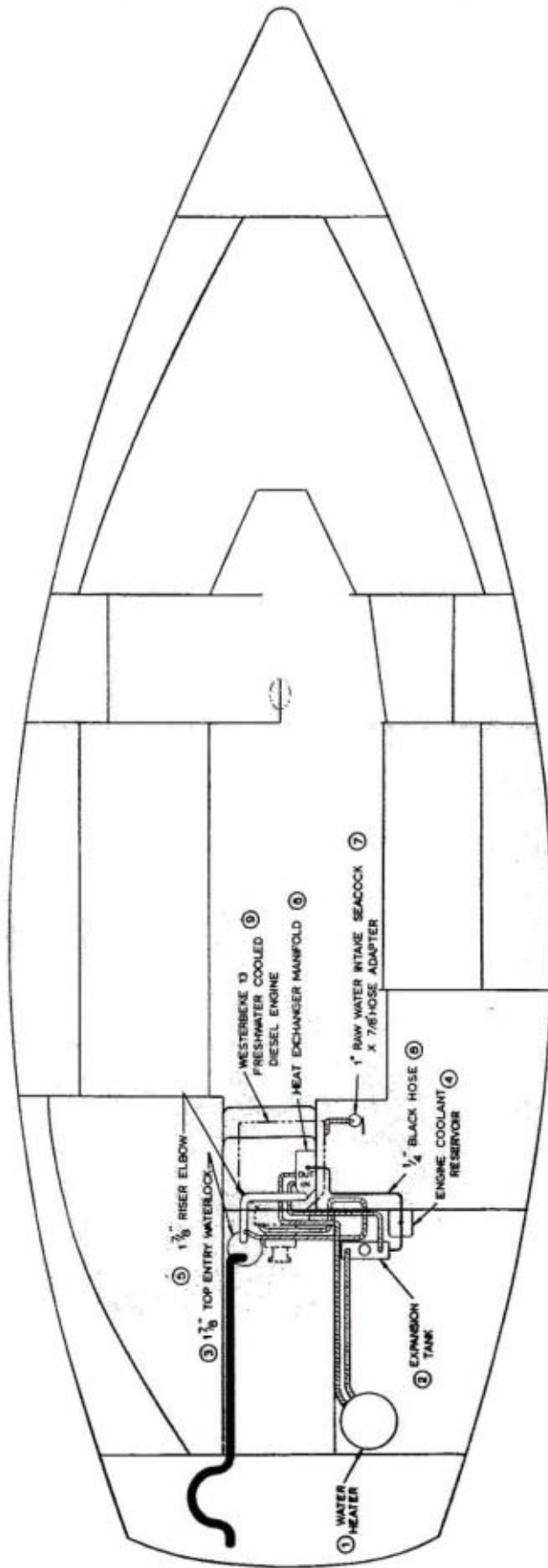

17B. ENGINE COOLING & HOT WATER SYSTEM

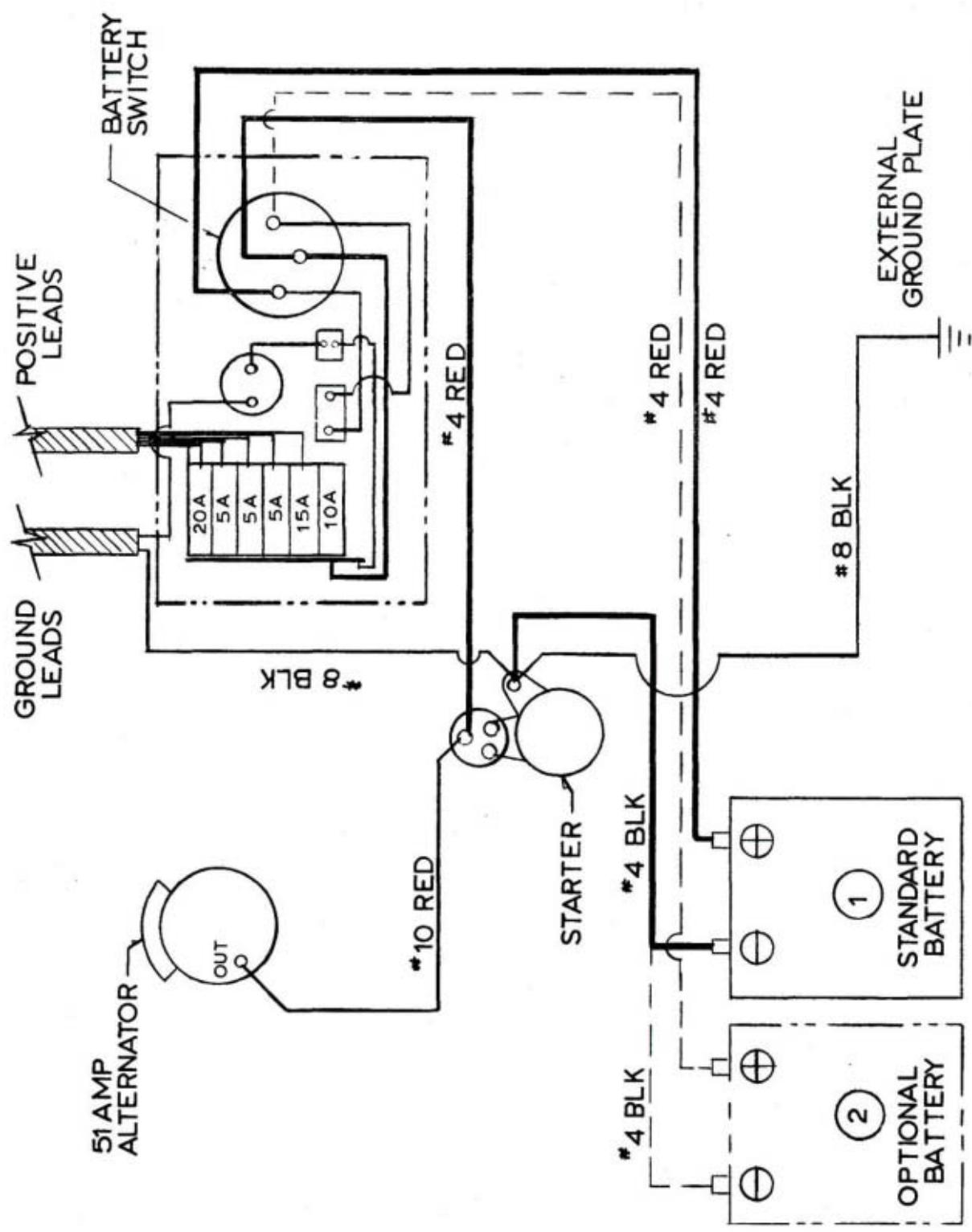

18. DC PANEL WIRING

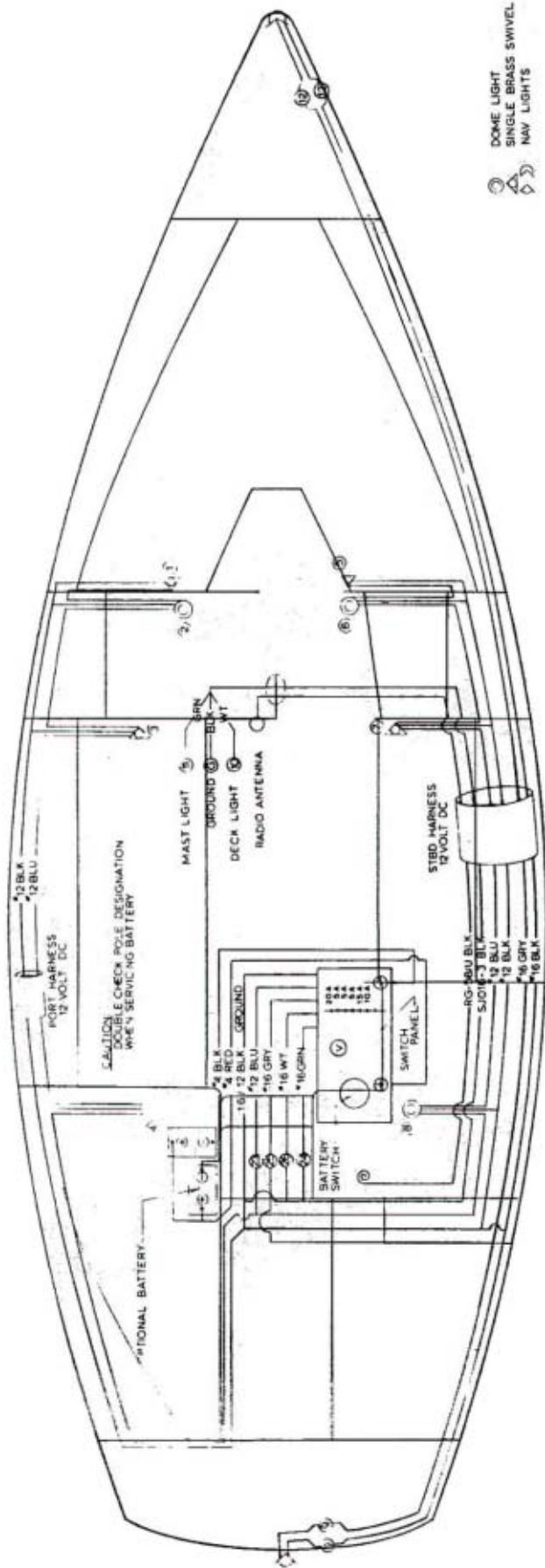

19A. 12 VOLT DC WIRING

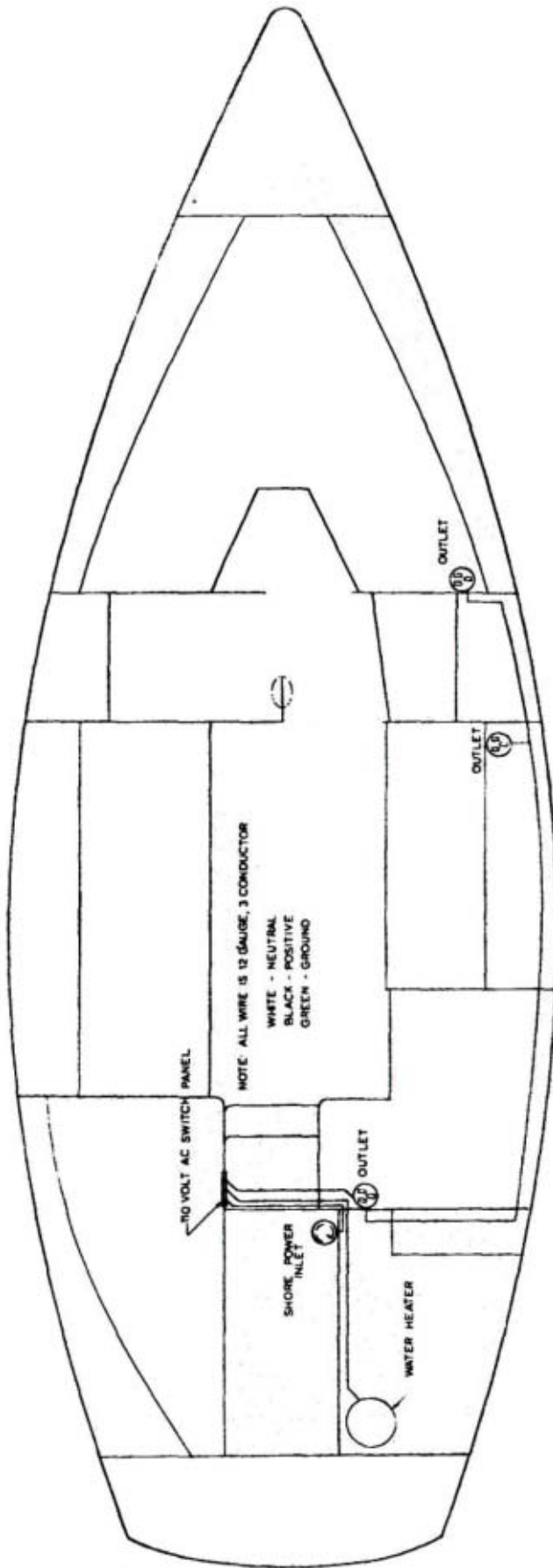

19B. 110 VOLT AC WIRING

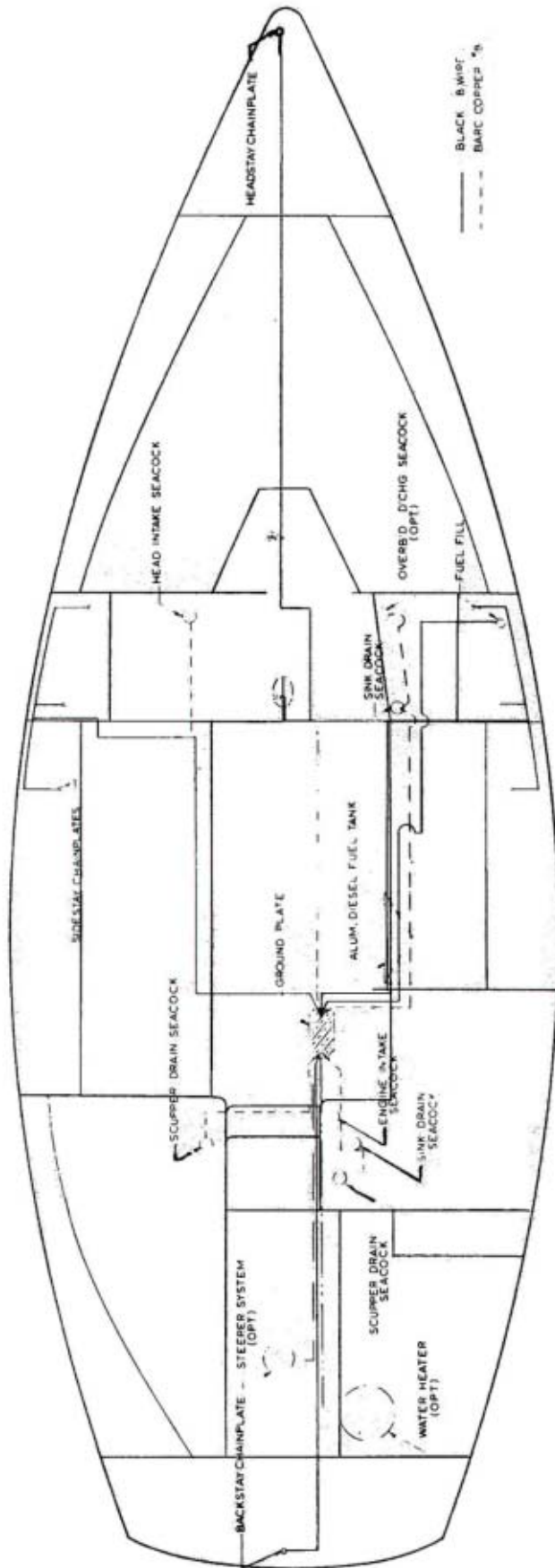

20. LIGHTING GROUND & UNDERWATER BONDING

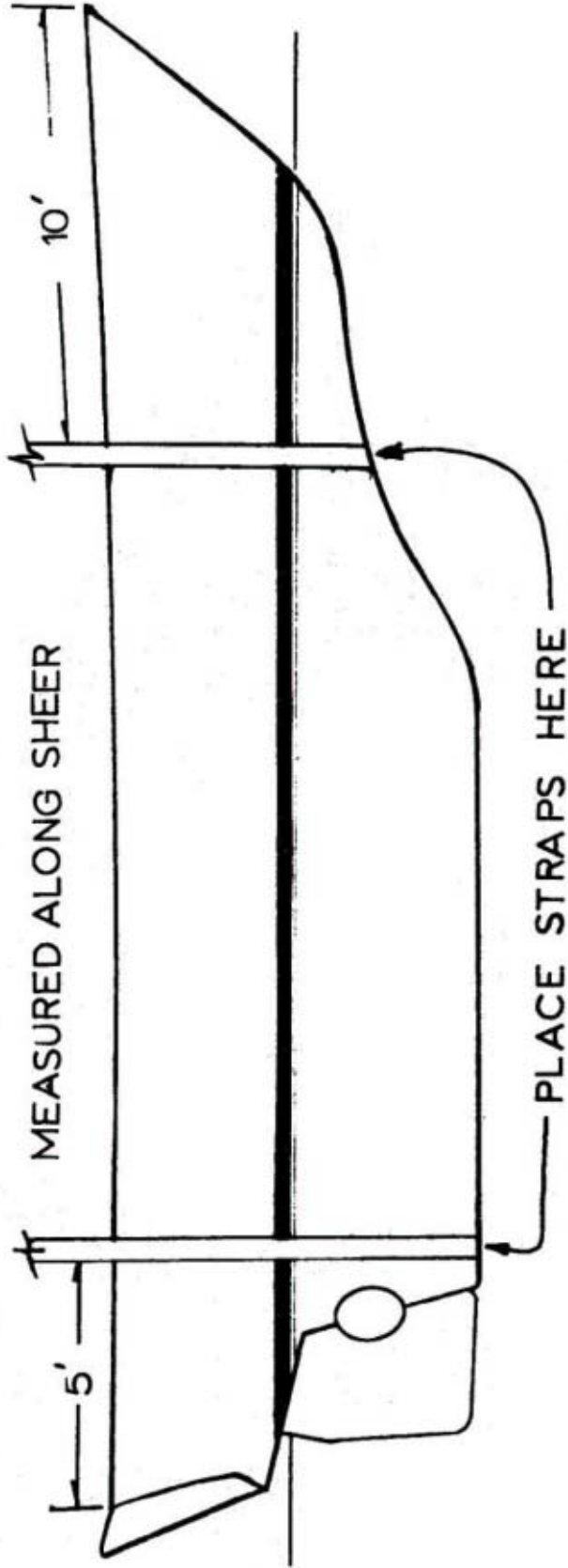

MEASURED ALONG SHEER

10'

5'

PLACE STRAPS HERE

NOTE: AVOID PLACEMENT OF THE AFTER STRAP UNDER THE RUDDER AND FORWARD STRAP OVER ANY TRANSDUCER THRU HULL

21. LIFTING STRAP LOCATION