

OWNER'S MANUAL

**CAPE
DORY
YACHTS**



INCORPORATED

CAPE DORY
33

COPYRIGHT 1983
CAPE DORY YACHTS, INC.
All Rights Reserved.

Third Edition – May, 1983

No part of this book may be used or reproduced in any manner whatsoever without the express written permission of Cape Dory Yachts, Inc.

All material and specifications are subject to change without notice.

LETTER OF WELCOME

Dear Skipper,

Welcome to the Cape Dory fleet!

You have joined the select group of sailors who recognize the quality construction and traditional workmanship found in every Cape Dory yacht.

This manual has been prepared to assist you in getting to know your new yacht before setting sail for the first time. It also is a helpful guide to follow for proper care and maintenance in the future.

The Cape Dory team of managers, supervisors and quality control personnel do their very best through every step of the construction process and strive to build boats of exceptional quality which will provide their owners with many years of sailing pleasure and retain a high resale value.

Please review the material carefully. You will enjoy your new Cape Dory more if you are familiar with the designs and construction of the yacht and with the equipment used on board.

Any questions you may have can be answered by your authorized dealer as he is a knowledgeable professional and is familiar with your new boat. He will continue to be your most important contact for information about your boat and for any problems should they develop.

We appreciate your confidence in our product and assure you that with proper care, you should have many years and miles of enjoyable sailing in your new Cape Dory.

Again, welcome to the fleet. May the wind always be fair.

Sincerely,



Andrew C. Vavolotis
President
Cape Dory Yachts, Inc.

CAPE DORY OWNER'S ASSOCIATION

The Cape Dory Owner's Association was formed as the company grew from its original beginnings in 1964 as a sailing dory builder. The earliest Cape Dory owners would gather for regattas, races and picnics in summer and during the frostbite season in the winter months. Later, as the Typhoon spread in popularity, more and more activities began taking place involving that class. With the advent of the Cape Dory 25, other Cape Dory owners readily welcomed the newcomers.

Today, the Cape Dory Owners Association is national in scope, and activities are increasing in number rapidly. Several Typhoon fleets are actively established and most Cape Dory owners find the Association an excellent means of communication. The Association publishes a periodic newsletter which contains interesting as well as helpful information.

If you are a Cape Dory owner, and are not receiving the newsletter, please write to us and we'll enroll you immediately. We need to know your name, address, and the model and hull number of your Cape Dory.

Cape Dory Owners Assoc. P.O. Box 11 East Taunton, Mass. 02718	CAPE DORY YACHTS <small>INCORPORATED</small> 
<input type="checkbox"/> I own a Cape Dory _____ hull no. _____ Please enroll me in the Cape Dory Owners' Association.	
<input type="checkbox"/> I really don't own a Cape Dory, but I'd like to know more about your boats. Please send information and the newsletter.	
Name _____	
Street _____	
City _____ State _____ Zip _____	
I moor the boat in _____ and sail mostly in _____	

Table of Contents

Chapter 1 INTRODUCTION

Chapter 2 CONSTRUCTION

- 2.1 Hull
- 2.2 Deck and Headliner
- 2.3 Ballast
- 2.4 Rudder
- 2.5 V-Berth, Galley Floor and Sub-Floor
Assembly
- 2.6 Engine Installation
- 2.7 Mechanical Installation
- 2.8 Hull to Deck Joint
- 2.9 Chainplate System

Chapter 3 STEERING

Chapter 4 ELECTRICAL SYSTEM

- 4.1 D.C. 12 Volt System
- 4.2 A.C. 110 Volt System

Chapter 5 GROUNDED SYSTEMS

- 5.1 Bonding System
- 5.2 Lightning Ground System

Chapter 6 THRU HULLS AND SEACOCKS

Chapter 7 ENGINE SYSTEMS

- 7.1 Electrical Engine System
- 7.2 Exhaust System
- 7.3 Cooling
- 7.4 Fuel System
- 7.5 Shafting
- 7.6 Maintenance
- 7.7 Winterization

Chapter 8 PRESSURE WATER SYSTEM

Chapter 9 HEAD SYSTEM

Chapter 10 SAILCARE

Chapter 11 INTERIOR MAINTENANCE

- 11.1 Cushions
- 11.2 Ice Box

11.3	Ports	
11.4	Curtains (optional equipment)	
11.5	Sinks	11.5
11.6	Head	
11.7	Interior Wood Surfaces	
11.8	Stoves	
11.9	General	
Chapter 12 EXTERIOR MAINTENANCE		
12.1	Gelcoat	
12.2	Running Rigging	
Chapter 13 RIGGING INSTRUCTIONS		
13.1	Stepping the Spar and Tuning	
Chapter 14 WINTERIZING		
Chapter 15 SAFETY		
15.1	Weather Forecasts	
15.2	Boating Safety Organizations	
15.3	Warranty notification Procedures	
Chapter 16 DRAWINGS & SAIL PLAN		
16.1	Sail Plan	
16.2	Layout	
16.3	Technical Information	
16.4	Standing Rigging	
16.5	Running Rigging	
16.6	D.C. Wiring Layout	
16.7	A.C. Wiring Diagram	
16.8	D.C. Wiring Diagram	
16.9	Plumbing Layout	
16.10	Head System	
16.11	Pressure Water System	
16.12	Hull/Deck Joint	
16.13	Chainplate Reinforcement	
16.14	Lifting Strap Placement	

CUSTOMER SERVICE

The Cape Dory Yachts Customer Service Department has been established to provide technical information and a replacement parts ordering service for Cape Dory Owners.

Please do not hesitate to contact us with any questions or comments on your boat. We appreciate any suggestions that you might have to improve the product.

We suggest that you place any parts orders through your Cape Dory Dealer, but will be happy to accommodate you for special orders. Whenever you make an order, please provide the dealer or Cape Dory with your hull number and an accurate description of the part.

Situations may arise when we will be referring you to local marine stores or marine hardware manufacturers. Our intent in these cases is to provide you with the fastest and least expensive service.

Through our customer service department we strive to maintain our reputation for product quality and excellent service.

Sincerely,

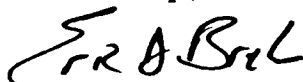

Eric J. Brehm



Karla J. Johnson
Customer Service Department

Chapter 1

INTRODUCTION

Cape Dory yachts are constructed in a recently remodeled building facility located in East Taunton, Massachusetts. Our boats are assembled using modern methods, equipment, and materials obtained from the most reputable suppliers. The Cape Dory team of managers, supervisors and quality control personnel do their very best through every step of the construction process. Cape Dory strives to build boats of exceptional quality which will provide their owners with many years of sailing pleasure and retain high resale value.

The basic hull design of Cape Dory yachts is a traditional one which has proven itself over many years of use and thousands of miles of cruising . The long keel with attached rudder hull configuration combined with a generous but not bulbous beam provides stiffness and longitudinal stability; it also provides protection for the rudder, propeller and propeller shaft. Our sail plans are not as lofty as those used on more race oriented designs of similar size. Instead of high aspect ratio main sails, Cape Dory has continued with what it considers to be a more sensible cruising sail plan. This means that a smaller head sail is needed, that a family or crew can handle a Cape Dory, and that the stresses on the rig and boat are less than those on high aspect ratio rigged boats under identical conditions. The interior layouts of Cape Dory yachts are designed to provide comfortable accommodations for a reasonably sized crew on boats of their size.

To protect your investment and to insure the enjoyment of your Cape Dory we recommend that you read this manual carefully and complete the Commissioning Checklist contained in it with your dealer. This list will serve as a guide in determining that no loss or damage has occurred to your boat while it was being transported from the factory to your dealer, and that all equipment is in order when you accept delivery. The checklist is for your protection; insist that it be completed. One copy must be returned to Cape Dory Yachts as a warranty registration. Once this registration process has been satisfactorily completed, your dealer will, if necessary, be able to file warranty claims for parts or service. He cannot do so unless the checklists are completed and returned. You will also become a member of the Cape Dory Owners' Association.

CAPE DORY OWNER'S RECORD

Complete and save this form for your records and future reference.

Yacht Name _____ Home Port _____

Hull Identification Number * _____

Dealer Name _____ Address _____

Salesman _____ Delivery Date _____

Date Commissioning Checklist/Warranty returned to CDY _____

* * * * *

Owner's Name _____ Address _____

State Registration/Documentation _____

Engine Model and Serial Number _____

Head Model and Serial Number _____

Stove Model Number and Serial Number _____

Spar Number _____ Rigging Kit Number _____

*Your Cape Dory is identified by a hull identification number (HIN) on the starboard corner of the transom. This identifies the number of the hull and supplies government officials with additional information concerning the builder, and the year of manufacture. There is also a builder's plate with the hull number. In addition, there are serial numbers on your boat's engine (see the engine manufacturer's owner's manual) and on some of the accessory equipment which you may elect to have installed.

We recommend that you record these important numbers carefully and keep copies of them both at home and aboard (see "Owner's Record" form). These numbers and an accurate description of your property, in the event of theft, could be essential to their recovery.

Marking an inconspicuous place such as the inside of a locker, underside of a door or drawer, or the base of the mast with your initials, social security number or other unique "brand" may also aid in the prompt identification of your property, should the need to do so ever arise.

COMMISSIONING

Cape Dory dealers are chosen because they are knowledgeable professionals. Since you are bearing the launching and commissioning expenses of your new yacht you have the right to expect a thorough and professional job.

Please note that the checklist provided in this manual is to assist you and your dealer with the first launching of your boat. In subsequent years, you may wish to review this list in preparing your boat for launching.

Before your boat is launched, we strongly recommend that you read the entire manual. In particular, read and become familiar with the Dealer's Commissioning Checklist as this is really a step by step set of instructions for launching your yacht.

DEALER'S COMMISSIONING CHECKLIST - PAGE 1

Model _____ Hull Number _____

Owner's Name and Address _____

Dealer _____

Date Sold _____ Date Launched _____

* Indicates further information and/or drawings elsewhere in manual

1.1 Date Initials Receiving Record

1. _____ _____ * All items on receiving checklist received in good order. Dealer should notify factory within ten (10) days of receipt, of any shortages or damaged goods.

PRE-LAUNCH CHECKLIST

2. _____ _____ Visually check underwater hull surface for any damage sustained during trucking or handling.

3. _____ _____ Through hulls all tight and clear of any foreign objects.

4. _____ _____ * Seacocks and valves all closed. Hose clamps tight.

5. _____ _____ * Check propeller nut and perry nut for tightness.

Record propeller information below:

Diameter _____ inches

Pitch _____ inches

Rotation _____ left or right hand

of blades _____ (2 or 3)

6. _____ _____ * Rudder swings freely side to side.

7. _____ _____ * Stuffing box packing adjusted
(Inspect to make sure packing is properly installed.)

8. _____ * Bottom under cradle poppets or bulkheads sanded, primed, and painted (Fresh coat of bottom paint prior to launching, highly recommended)
 9. _____ Bilge dry
 10. _____ * Bilge pump connections okay and handle on board
 11. _____ Check hull for any chips in gel coat
- POST-LAUNCH CHECKLIST:
12. _____ Immediately after launching, check bilge for water. If water is present, check all through hulls and stuffing box
 13. _____ Open seacocks one at a time and check for leaks
 14. _____ * Check stuffing boxes. The propellor stuffing box should drip water slowly, approximately one drop every ten seconds while shaft is turning to insure that the bearing and packing gland are lubricated by water. The rudder shaft stuffing box may not weep at all except in rough conditions.
 15. _____ * Check battery switch and electrical system operation
 16. _____ Check battery water level and charge level
 17. _____ * Check head operation
 18. _____ * Check bilge pump operation
- ENGINE START-UP CHECKLIST:
19. _____ Check engine and transmission oil level & condition
 20. _____ Check belt tension on all belt driven components
 21. _____ * Check that cooling water intake seacock is open
 22. _____ Check to see that all clamps on exhaust hose are tight
 23. _____ On fresh water cooled engine check water level and antifreeze in the expansion tank
 24. _____ Check engine mount nuts for tightness
 25. _____ Check transmission bolts for tightness
 26. _____ * Check shift and throttle cable connections
 27. _____ * Check prop shaft alignment using feeler gauges - .002" gap between flanges maximum - Note: Alignment should be checked several times during

the first season after the rig has been tensioned and the flexible mounts have taken a set

28. _____ Check prop shaft set screws, and see that they are wired in place
29. _____ Start engine according to the manufacturer's recommendations. Failure to start may be due to air in the fuel lines. Refer to manual for bleeding directions
30. _____ Immediately after engine starts, check to see that water is coming out of the transom exhaust port.
31. _____ Check gauges and/or warning lights
32. _____ Check entire system for water, oil, fuel, or exhaust leaks. Note: sealers and paints may burn off as engine heats up the first few times
33. _____ * Check throttle and shift operation.
34. _____ * Recheck stuffing boxes
35. _____ * Report any unusual noises or vibrations to the factory immediately. Do not continue to run engine if any are present.

RIGGING CHECKLIST:

36. _____ Check all fasteners on spars for tightness
37. _____ * Reeve halyards
38. _____ * Attach stays, shrouds, spreaders and topping lifts. Wire or seize end of spreaders to upper shrouds. Spreaders should angle slightly upwards and bisect the angle formed by uppers.
39. _____ Check all clevis pins and cotter pins for security. Tape all potential chafe points including spreader bases and ends
40. _____ * Check wiring of combination deck and bow light. Be sure bulbs work prior to stepping mast.
41. _____ Step mast and rigging
42. _____ Check all rigging for length

43. _____ Check all clevis and cotter pins for security. Be sure the locking nuts on the turnbuckles are secure. Tape all potential chafe points.
44. _____ * Tune rigging to proper tensions
45. _____ Chock the spar with mast wedges. Drill for the mast collar pin after test sailing and tuning is complete
46. _____ * Attach booms, sheets, blocks, reefing lines, topping lifts, etc.
47. _____ Wire bow and deck lights
- MISCELLANEOUS CHECKLIST:
48. _____ * Fill water tanks and check operation of all pumps and drains
49. _____ Fill alcohol tank. Check for leaks and test operation of stove. See manufacturer's literature on all stoves.
50. _____ Water test ports and hatches
51. _____ * Recheck all through hulls, valves, seacocks, hose clamps, hoses, and stuffing boxes.
52. _____ * Bend on sails
53. _____ * Interior appointments complete
54. _____ Optional equipment installed and operational
55. _____ Owner's packet, ship's papers, and ignition key given to owner
56. _____ Checklist (warranty registration) ready for mailing to factory.

I CERTIFY THAT I HAVE READ AND UNDERSTAND THE CONDITIONS AS LISTED
IN CAPE DORY YACHTS' WRITTEN LIMITED WARRANTY.

Owner _____

Dealer _____
WITHIN SEVEN DAYS OF LAUNCHING

Date _____

RETURN CHECKLIST TO:
Cape Dory Yachts, Inc.
160 Middleboro Avenue
East Taunton, Mass. 02718

Chapter 2

CONSTRUCTION

2.1 Hull

The hull is molded in a one piece mold which is turned from side to side as successive layers of fiberglass are applied during the laminating process. By placing the mold on its side we can place the fiberglass and work the resin more accurately than would be possible if the mold was always upright.

The exterior finish of the boat is pigmented gel coat which is sprayed into the polished mold. Next, we apply two layers of multidirectional glass strand fiber to minimize roving pattern transfer from successive layers of laminate.

Finally, alternating layers of glass strand fiber and woven roving are applied until the desired thickness has been achieved. The thickness of the hull varies depending on the structural requirements a particular area needs, with the thickness increasing as you go from the sheer to the keel area.

2.2 Deck and Headliner

Like the hull, the deck is molded in a one piece mold as a single unit. All exterior surfaces, including the non-skid compound are pigmented gel coat molded into the deck.

The deck is laid up with glass strand fiber and woven roving incorporating a balsa core for stiffness and insulation. Where hardware and equipment are through bolted, wood blocks, aluminum or solid glass replace the core. In the highly stressed cockpit corners, unidirectional roving is utilized near the gel coat surface and on the back side of laminate, giving high flexural strength in these areas. This minimizes stress cracking.

The headliner is a fiberglass part used to provide a cosmetic surface to the inside of the cabin as well as providing attachment points for the major bulkheads. It also provides an effective vapor barrier and thermal insulation due to the air gap separating the deck and the headliner.

The headliner is built with glass strand fiber and woven roving. After it has been parted from the mold, key areas are filled solid so

that screws may be installed later. The headliner is then bonded to the deck accurately with a polyester adhesive compound. This is done with the aid of a jig that holds the liner in place while the adhesive cures. At this point the deck is parted from the mold and sent to the deck hardware department.

Some yachts, including the CD-45 have headliners made of plywood formica and teak which are backed up with a combination of plywood and fir fairing strips for fastening support. This system also provides an easily maintained interior surface with similar vapor barrier and insulating qualities.

2.3 Ballast

The ballast is cast in two sections and mounted inside the keel cavity. Its correct location is first determined, then it is prefit to ensure that the true shape has been maintained. The Quality Control Department accurately checks the location of every ballast, then records its weight against our specifications. Next it is lowered into and encapsulated in a mixture of special low shrink bonding resin and microspheres. Besides its shrink characteristics, the bonding resin was chosen for having some resiliency should the keel be subject to sharp impact loads.

The ballast is then sealed with several layers of fiberglass, securely holding the ballast into the hull. This glass is gel coated, sealing the ballast from the rest of the boat and giving a smooth, clean bilge.

2.4 Rudder

The rudder assembly consists of two pre-molded fiberglass half shells completely filled with a reinforced polyester compound. This compound surrounds the pre-formed rudder shaft creating a solid rudder of exceptional strength. The blade is further reinforced with two layers of glass tape applied to the shell joints.

The rudder shaft is a solid bar of type 304 stainless steel, 1-1/2" in diameter, bent to fit inside the rudder shell. A bronze gudgeon casting is imbedded in the bottom of the rudder to accept the bronze pintle casting which is attached to the keel. The pintle is set in polysulfide bedding compound and fastened onto the hull with bronze rods passing through the solid heel portion of the keel. The entire casting is then faired with polyester putty and glassed into the keel. This eliminates the electrolysis problem commonly found when stainless steel weldments are used in seawater.

2.5 V-Berth, Galley Floor and Sub-Floor Assembly

The v-berth area has a molded liner which starts at the main cabin bulkhead and runs all the way forward to the anchor rode locker. This is built as the other FRP parts are, utilizing various cores and laminates as required.

It is then installed in the hull where it is glassed to the hull with two layers of alternating mat and roving. In some places the liner is joined further to the hull using a polyester adhesive.

The galley area also has another separate molded liner very similar to the v-berth in concept.

The molded fiberglass sub-floor assembly is designed to fit accurately and lock to the contours of the hull. This is bonded in place and a teak and holly sole is screwed down to it. This is installed after the v-berth and galley units are in place.

Fiberglass inner liners offer three basic benefits:

1. added structural integrity
2. minimizes condensation problems
3. provides an easy-to-clean surface in storage areas

2.6 Engine Installation

One of the more critical installations we perform is the installation of the inboard diesel engine. The diesel is installed with fully adjustable flexible mounts attached to a heavily reinforced welded steel engine bed. This system effectively spreads the engine load over a large portion of the hull.

The exhaust is a wet system consisting of a fiberglass muffler and heavily reinforced rubber hose. The main advantage of this type of exhaust system is that it allows the cooling water to cool the exhaust gases as they leave the engine. This system produces a quieter sound and reduces temperatures in the engine room preventing burns and minimizes a fire hazard.

The fuel system incorporates a custom aluminum fuel tank and a combination of flexible fuel lines and reinforced rubber hose. Flexible fuel lines have been chosen as they are very easily repaired in the field should a leak develop. Copper fuel lines require special tools to repair which may not be available at sea. Every installation includes two fuel filters for that extra measure of safety.

2.7 Mechanical Installation

While the carpenters are completing their joiner work, the bulk of the mechanical installations are completed. The water tank mounting pans are glassed into place and the tanks installed. The plumbing is run to the manifold located under the galley sink and then into the respective compartments where the pumps and water heater are located. The heavy wiring from the engine is run up to the electrical panel. The lightning ground system wires are run from the areas where the chainplates will later be fitted to the external ground plate located in the bilge. The bonding system joining all underwater thru hulls is completed.

The holding tank, which was installed when the ballast was installed, is plumbed and hoses running under the sole from the head itself to the tank are run. Chainplate tangs are secured to the bulkheads and the alcohol line is run. The engine plumbing including the water, exhaust and fuel lines are run and secured at this time.

The engine is aligned and the stuffing box on the prop shaft and rudder shaft receive final attention along with the upper rudder bearing assembly.

2.8 Hull to Deck Joint

When most of the major components of the interior have been installed, the hull is made ready to receive the deck. Built into the hull is an internal hull flange approximately 3-1/4" wide and 3/8" thick. (See the enclosed drawing for details of this assembly.) This internal flange is made up of the same layers of woven roving that form the topsides of the hull.

The deck is raised over the hull and the process of fitting the deck to the hull is begun. All bulkheads are carefully scribed and cut until the deck rests on the hull flange.

The flange is then prepped and coated liberally with a special polyester bonding material and the deck bonded into place. The joint is later thru-bolted by 1/4" bolts on 12" centers. A teak toe-rail is then screwed down with #14 screws through the deck and the hull flange, adding to its strength. A teak rub strake is finally added, completing the installation.

We feel our deck to hull joint to be one of the best for several reasons:

1. The flange should be internal. This gives the largest possible flange area, important for flexural strength. Also, boats with external flanges are subject to damage and leakage when run hard into a dock or other immovable objects. Impact in this area

starts a crack that water is sure to find its way through under normal sailing conditions.

2. We use a semi-rigid bonding compound between the hull and the deck as well as through bolts. Due to the abrupt angular discontinuity created at the hull/deck intersection, large forces can be built up while underway. It is best to prevent movement here, otherwise things start to work and leaks occur. A rigid compound used here might seem the best but they generally don't have enough impact strength and resiliency to prevent leakage over a long period of time.
3. Many builders use aluminum toe rail extrusions and thru bolt this structure every 4". This is a very difficult assembly to keep watertight because the fastener heads are exposed while our bolt heads are covered over and the toe rail screws are bunged.
4. The strength of the bonded and bolted hull/deck is greater than the thru bolted joint. If it takes about 1000 PSI to delaminate the joint and the joint is 3" wide, over a 4" length, you need $(4 \times 3 \times 1000)$ or 12,000 lbs. of force to rupture it. On a boat that is thru bolted every 4" you have the strength of one bolt to contend with (provided they haven't used a semi-rigid adhesive). The shearing strength of a 1/4" stainless steel bolt generally won't exceed 4000 lbs. and thus is considerably weaker than the bonded joint.

2.9 Chainplate System

Our chainplate system is easy to understand and does what any chainplate system must do - transmit the rigging loads to the hull and not leak. We use chainplate castings with substantial base areas so that when installed and caulked the resulting seal is impervious to water penetration. Thru bolting the casting to the hull flange also prevents movement in this area. Many builders attach chainplates to the knees glassed to the hull. These plates then pass on through the deck. It is virtually impossible to prevent the deck from moving in this type of installation and hence the resulting leaks.

Every Cape Dory chainplate design has been subjected to structural evaluation including destructive pull tests assuring that they meet our structural requirements. All bolts are tightened to specific tolerances using a torque wrench.

The rigging was designed using a safety factor of 3 while the chainplates were designed to meet a minimum safety factor of 4.

Please refer to the drawing for further details.

Chapter 3

STEERING

The pedestal steering system on your Cape Dory has been carefully designed, installed and aligned here at the factory to give you excellent service with minimal maintenance.

A steel weldment comprised of the pedestal sheaves, wire turning sheaves and quadrant stop is bolted under the deck tying the entire sheave assembly into one integrated unit. This is fastened in place by the four pedestal bolts to the cockpit sole and also bolted to the cockpit head transmitting the loads of the steering system over a wide area.

The weldment also has a quadrant stop, limiting the swing of the rudder to about 35 degrees port and starboard. This is especially useful when motoring in reverse, as the rudder would tend to swing completely to one side with great force resulting in possible damage to either the hull or steering system.

During installation we have replaced many of the vendor supplied nuts with self locking nuts as we have found they will otherwise loosen during road transit, engine vibration and general use.

It is imperative that the owner take the initiative to inspect the steering system for proper wire tension, wire alignment, and fastener tension during the sailing season. Periodic maintenance is also required on all moving parts. In particular, the lubrication of the bronze sheaves is critical to the smooth operation of the steering unit.

The keyway that is cut into the rudder shaft is purposely cut a little long to accept an attachment for a number of automatic pilot systems. This saves a very costly alteration from having to be performed in the field were another keyway to be cut and eliminates the need to bolt something to the shaft which would tend to weaken it.

The head of the rudder shaft above the pillow block bearing has been keyed to accept an emergency tiller. Access for this is gained by removing the bronze deck plate in the cockpit sole.

Should anything ever happen to your primary steering system, the key for the deck access plate and the emergency tiller should be readily accessible and not buried in the bottom of a locker.

Please review carefully the enclosed maintenance hints supplied by the vendor. A thorough understanding of how your steering system works is the only way you can be assured of its proper performance year after year.

Chapter 4

ELECTRICAL SYSTEM

Your Cape Dory has been equipped with a comprehensive electrical system designed to meet your present and future needs. Wiring runs and connections are placed to prevent exposure to water or other hazards, yet to remain accessible for repairs or additions. The A. C. (alternating current - Shore Power) and D. C. (Direct Current - Ship's Power) wiring is plastic coated, stranded copper wire with crimped-on connectors or soldered joints as required. The electrical system is basically maintenance free, with only the batteries requiring periodic inspection.

4.1 D.C. 12 Volt System

The D.C. system is powered by 12 volt, 75 amp hour batteries located in the cockpit seat lockers. They are enclosed in an impact resistant, noncorroding plastic case which is firmly attached to the hull. All Cape Dory yachts use the standard negative ground system which must be considered when purchasing and installing additional equipment.

The batteries are controlled by means of the Battery Selector Switch located on the bottom of the D.C. Power Panel which is in the companionway area. This switch acts as a master disconnect as well as a selector for battery #1, battery #2 or batteries #1 and #2 together. Commonly one battery is reserved for engine starting duty while the second battery supplies all other needs.

CAUTION: NEVER TURN THE BATTERY SWITCH TO THE OFF POSITION WHILE THE ENGINE IS RUNNING. SERIOUS DAMAGE TO THE ALTERNATOR WILL RESULT.

The level of charge of the batteries may be checked with a Battery Condition Meter located in the center of the D.C. Power Panel. The level of charge of the battery, alternator output, state of the voltage regulator and power draw to services can all be checked with the use of the DC voltmeter supplied on the 12 volt power panel. A voltmeter gauge is located on the engine instrument panel. Your voltmeter will indicate differently, depending when the readings are taken. Here are a few simple guidelines. Fully charged batteries that are in a static state should read between 12.3 - 12.6 volts on the numerical scale, and just barely be touching the high end of the yellow band on the colored dial of a gauge (The term static means that the battery hasn't been charged or discharged for at least two hours). If the pointer is in the yellow, or red low band on a gauge, or reads between 11 - 11.5 volts on a voltmeter, then the battery is

about half discharged and should be charged to insure its usefulness. If the engine is started, and the needle does not move up this would indicate that no charge is being delivered to the battery.

When the battery is being charged, the pointer should be between 12.6 - 13 volts, which is approximately the center of the green band on gauge types. The pointer may move up to about the 13.7 volt range (the high end of the green band) toward the end of the charge cycle, at which time the pointer drops back to the 12.6 - 13 volt range, as voltage regulation controls this function. If the battery voltage reaches 15 volts (which is the high red band on the gauge) this indicates that the battery is being overcharged and will damage the battery if left unchecked. The voltage regulator is most likely at fault.

When the battery is being discharged (having electrical loads placed upon it) and no charging current applied, it is normal for the pointer to indicate between 11.4 - 12.6 volts, or be in the yellow band.

A Final Word: The above guidelines provided are merely to help you to establish what is normal - the usefulness of the meter will depend on your own routine observations which will spot trouble when it occurs.

The Battery Test Switch adjacent to the meter is used to directly connect the meter to the individual batteries. The condition may then be read directly from the meter. The Battery Selector Switch must NOT be in the ALL position and the engine should NOT BE RUNNING or false readings will result.

The batteries should be inspected and serviced at least once a month, more frequently when under heavy use. The terminals should be free from corrosion and tight on the battery posts and the electrolyte kept at the proper level by topping up with distilled water.

CAUTION: Avoid spilling battery electrolyte into the bilge and avoid getting any salt water in the battery. If this should occur, ventilate extremely well since poisonous gas will be given off.

A red PILOT light is provided on the panel. This light is illuminated whenever the batteries are connected to the system and provides you with an additional reminder that the batteries are on and also provides enough light to read the switch panel labels at night. The pilot light draws very little current and will not run the batteries down even when left on for long periods of time.

There are ten individual circuits provided on the D.C. Power Panel. Each circuit is activated by a toggle switch and protected by a circuit breaker. Before adding additional electrical equipment, check the required rating of the circuit breaker. Also be certain the number and size of the batteries is sufficient for the added loads.

A tripped circuit breaker is indicated by a raised white button. The breaker is reset by first turning the toggle switch off and then depressing the white button. Before attempting to reset a tripped breaker, an effort should be made to find the cause of the overload, the most common being a short circuit in one of the fixtures or wires, or trying to operate too many devices on one circuit.

4.2 A.C. 110 Volt System

The A.C. system operates on 115 volt, 60 cycle current. Power is supplied from a 30 amp shore service by connecting the shore power cord to the receptacle in the cockpit well. Make sure the main circuit breaker on the A.C. Power Panel is in the off position when connecting the shore power cord.

IMMEDIATELY after connecting the shore power cable, check the 110 pilot light. If it is on and the main breaker off this indicates a live circuit from the shore power receptacle. Next check the reverse polarity indicator light. If it is on, disconnect the shore power cable IMMEDIATELY and determine the source of the problem as serious electrical shock hazards may exist to persons on board or along side your yacht, even if the main circuit breaker is off. The ship's wiring has been thoroughly checked and is of the proper polarity when it leaves the factory. If the system has not been altered, the reverse polarity condition is in the shore side system and should be brought to the attention of the system operator. If the reverse polarity light does not come on, the system is safe to operate. Turn on the Main Circuit Breaker at the top of the panel and then select whichever branch circuit is needed.

CAUTION: Before turning on the hot water heater insure that the tank is full of water. Permanent damage will result from operating the heater with an empty or partially full tank. To check that it is full, simply open the hot water tap on the pressure water system and watch for continuous water flow.

(On each Cape Dory that has been fitted out with a factory installed 110 volt AC system we have included or added a #8 green coated copper wire as a ground. This wire is led from the common AC ground to the engine, and is in turn tied into the boat's ground system.)

This ground cable is a safety feature installed to avoid serious electrical shock hazards should a connection to a faulty dockside power source be made.

Under no circumstances should this cable be disconnected irrespective of claims that a certain amount of electrolysis could be created by the addition of this wire.

Chapter 5

GROUNDED SYSTEMS

5.1 Bonding System

All thru hulls and seacocks below the waterline, including the stern tube, are connected to one another, to the engine block and to the external ground plate with a continuous loop of #8 copper wire. This is done to minimize the effects of electrolysis should one fitting become "hot" for any reason. Generally, a fiberglass hull is considered to be non-conducting and as such the chance of stray electrical currents forming is minimal.

As more and more electrical equipment is added to a boat, it becomes increasingly important to be alert to the threat of electrolysis. We recognize that there are various types of instrumentation available to further monitor strong currents and any potential difference between ground and the thru hulls. These instruments can all be added to the supplied ground wire system.

5.2 Lightning Ground System

Your Cape Dory is equipped with a lightning ground system installed in accordance with the American Boating and Yacht Council (A.B.Y.C.) specifications. Every shroud and stay is connected to an external ground plate by a #8 a.w.g. stranded copper wire. Other equipment requiring bonding include the engine, fuel tank, mast step and fuel fill cap. Within practical working restraints, the wires are lead directly to the ground plate.

While no one can predict how lightning will react when it hits a spar, we know from actual experience that this system offers added protection.

During a lightning storm refrain from touching any metal objects such as shrouds, mast, stanchions, pulpit, etc., as these may attract lightning.

Do not paint the external ground plate with bottom paint as this prevents the plate from grounding out with the seawater.

Periodically inspect the connections in the bilge to see that they are tight and clean and free from corrosion.

Chapter 6

THRU HULLS AND SEACOCKS

Since some holes below the waterline are necessary, seacocks are used to open and close those reliably. They have been in use for years aboard craft of all types, and have proven their value many times over.

The seacock is essentially a round tapered bronze shaft with a hole running along its diameter. It can be rotated from one end in a 90 degree arc within a pipe junction to the open or closed position. The seacock is least likely to jam open with seaweed or other foreign matter.

Before launching, and regularly throughout the season, you should check to see that all thru hull nuts are tight, that seacocks are working properly and that all hose clamps are tight and in good condition. Seacocks are designed to provide a positive means of stopping a flow of water into the hull, should a connection fail or hose rupture. These fittings are the single most important safety devices that affect the watertight integrity of your boat. Checking them for ease and effectiveness of operation means making certain that the handles move the full arc that they were designed for, and that sinks, toilets, and cockpits drain easily when filled.

Whenever the boat is left unattended in the water, all thru hull fittings should be left in the closed position except for those serving the cockpit scuppers. Be certain to open the engine cooling seacock before starting a diesel engine. The water pump impeller could be damaged and/or the engine and exhaust system damaged by overheating if the engine were to be started with the seacock closed.

Routine maintenance of seacocks calls for disassembling them when the boat is out of the water, applying a waterproof grease to all friction-bearing parts and reassembling. When disassembling seacocks, do so one at a time as the components are individually fitted to each other by their manufacturer. Your dealer or marina will suggest a good grease available in your locality. Automotive water pump grease or lubriplate may be used.

Seacocks should be worked frequently to keep corrosion from forming, causing them to jam.

To disassemble your seacock - there is a locknut on the outer end of the shaft - back it off and remove it. Next, back off the hexagonal end plate, removing it completely from the shaft. Then from the opposite end, pull the shaft out of the housing. Do not use a hammer or hard object to force the shaft out of the barrel as you may damage the threads. After you have cleaned off the old grease - inside and out - replaced it with new grease, reverse the procedure and

reassemble. Be sure that you tighten the end plate tight enough so that the seacock will not leak, but not too tight or the mechanism will not turn. A thin layer of lubricant between the end plate and locknut will facilitate tearing down next season. For obvious reasons, this procedure is to be carried out while the boat is out of the water.

Your seacocks for the cockpit drain should almost always be left open. Their primary function is to be able to shut off a flow of water should the drain hose burst or come disconnected. Because these are the least used seacocks on the boat, there is a tendency to forget that they are there. DON'T! Work them frequently, and service them annually so that they will work should an emergency arise. Leave all seacocks open when the boat is stored for the winter so there is no freezing damage.

The other seacocks should normally be left in the closed position when you leave the boat. Be sure that you establish a routine of opening and closing seacocks so that you don't overheat your engine or burst hoses in the head. Since the head bowl is near the waterline particular attention should be paid to the seacocks that serve the head. They should be shut off anytime you are asleep or off the boat. A malfunction in the head or leaving the head intake valve open could cause the boat to flood or sink if undetected. Simply closing the seacocks eliminates this hazard. Set up a routine to do this all the time.

Chapter 7

ENGINE SYSTEMS

The engine fitted in the CD-33 is the Universal 30 Diesel. This is a 4 stroke diesel with direct fuel injection. There are 3 cylinders with a total displacement of 68 cubic inches. A hefty flywheel is mounted to dampen vibration and 2:1 reduction gear/transmission provides the output. Parts and service availability are excellent due to the fine Universal network in this country.

The engine installation is best broken down into several systems and a description of each system follows. The systems are electrical, exhaust, cooling, fuel, shafting, maintenance and winterization. Included in each section is our experience of what has gone wrong with other boats which might help should you have a problem.

7.1 Electrical Engine System

All Universal 30's are fitted with a 55 amp alternator which charges the two batteries. The alternator has a transistorized regulator. Additionally there is an electric starter with a solenoid for remote starting. Fuel is pumped electrically and the engine is fitted with glow plugs for easy year-round starting.

7.2 Exhaust System

The exhaust gases enter a waterlock muffler mounted in the aft port side of the engine. Here they are mixed with the cooling water and forced out the transom. Little maintenance of this system is required. It is recommended that every time the engine is started you look over the transom to see if the cooling water is coming out with the exhaust. If it isn't, not only will the engine block overheat but the exhaust system will overheat as well. The routing of the exhaust hose should not be changed or problems may develop. For winterizing the exhaust system a drain plug is fitted to the exhaust muffler allowing it to be drained.

reassemble. Be sure that you tighten the end plate tight enough so that the seacock will not leak, but not too tight or the mechanism will not turn. A thin layer of lubricant between the end plate and locknut will facilitate tearing down next season. For obvious reasons, this procedure is to be carried out while the boat is out of the water.

Your seacocks for the cockpit drain should almost always be left open. Their primary function is to be able to shut off a flow of water should the drain hose burst or come disconnected. Because these are the least used seacocks on the boat, there is a tendency to forget that they are there. DON'T! Work them frequently, and service them annually so that they will work should an emergency arise. Leave all seacocks open when the boat is stored for the winter so there is no freezing damage.

The other seacocks should normally be left in the closed position when you leave the boat. Be sure that you establish a routine of opening and closing seacocks so that you don't overheat your engine or burst hoses in the head. Since the head bowl is near the waterline particular attention should be paid to the seacocks that serve the head. They should be shut off anytime you are asleep or off the boat. A malfunction in the head or leaving the head intake valve open could cause the boat to flood or sink if undetected. Simply closing the seacocks eliminates this hazard. Set up a routine to do this all the time.

Chapter 7

ENGINE SYSTEMS

The engine fitted in the CD-33 is the Universal 30 Diesel. This is a 4 stroke diesel with direct fuel injection. There are 3 cylinders with a total displacement of 68 cubic inches. A hefty flywheel is mounted to dampen vibration and 2:1 reduction gear/transmission provides the output. Parts and service availability are excellent due to the fine Universal network in this country.

The engine installation is best broken down into several systems and a description of each system follows. The systems are electrical, exhaust, cooling, fuel, shafting, maintenance and winterization. Included in each section is our experience of what has gone wrong with other boats which might help should you have a problem.

7.1 Electrical Engine System

All Universal 30's are fitted with a 55 amp alternator which charges the two batteries. The alternator has a transistorized regulator. Additionally there is an electric starter with a solenoid for remote starting. Fuel is pumped electrically and the engine is fitted with glow plugs for easy year-round starting.

7.2 Exhaust System

The exhaust gases enter a waterlock muffler mounted in the aft port side of the engine. Here they are mixed with the cooling water and forced out the transom. Little maintenance of this system is required. It is recommended that every time the engine is started you look over the transom to see if the cooling water is coming out with the exhaust. If it isn't, not only will the engine block overheat but the exhaust system will overheat as well. The routing of the exhaust hose should not be changed or problems may develop. For winterizing the exhaust system a drain plug is fitted to the exhaust muffler allowing it to be drained.

7.3 Cooling

The Universal 30 Diesel is fresh water cooled. As previously mentioned, the cooling water is discharged into the exhaust system. The cooling water enters the hull through a screened seacock and is pumped through a Jabsco impeller type pump mounted on the engine. If the engine is started with the seacock closed or water obstructed in another way, damage to the rubber impeller will result. A spare impeller should be carried aboard at all times and is easily changed. After the sea water has passed through the engine's heat exchanger, it is diverted through the heat exchanger in the sail locker, heating the potable water supply. After the water heater, the water passes through a vented loop located under the bridge-deck and is injected into the exhaust elbow, where it passes overboard. The vented loop is to provide antisiphon protection which will prevent a siphon from forming which could flood the engine. The antisiphon valve should be cleaned often so that it functions properly and does not spurt water.

As the engine is fresh water cooled, there is a separate loop that the engine cooling water must make. The fresh water comes in "contact" with the sea water in the engine's heat exchanger where it is cooled. Before it is cooled, the water has passed through the engine block and manifold and then through the potable water's heat exchanger. From here it goes to an expansion tank located in the sail locker. This tank must be the highest point in the fresh water loop to allow trapped air to escape and not block the flow of water. You should periodically inspect the water level in the expansion tank to be certain the water level is satisfactory. Never open the pressure cap on the engine as the entire cooling system will drain out and you will have to replace it through the expansion tank. The pressure rating on the expansion tank's pressure cap is considerably lower than on the one on the engine to prevent water from escaping there should the engine become overheated.

The fresh water used to cool the engine should have antifreeze in it to inhibit rusting and prevent it from freezing during the winter months.

7.4 Fuel System

In order to run, a diesel's only requirement is clean, waterfree, airfree fuel and combustion oxygen. There are no spark plugs or ignition requirements. 95% of all diesel engine problems result from fuel problems. The owner's manual that comes with the engine describes the bleeding procedures and every owner should know how to do this. The fuel feed line must be 100% air tight or it will suck in air which eventually will reach the high pressure pump and cause the engine not to start until this air is expelled. All engines are test run here at the plant and are fully bled, however air may be introduced in trucking or launching and must be bled out once the boat

is launched. The fuel system consists of rubber hoses secured with hose clamps and threaded fittings made tight with pipe dope tape or sealer. The complete fuel line from the pick-up tube in the tank to the fuel pump in the engine must be tight or air will be introduced.

All CDY engine installations incorporate two fuel filters which also must be air tight. Any time the fuel system is opened up, as when changing a fuel filter, air will be introduced into the system which must be bled out.

The only other problems that can occur are caused by dirty or water laden fuel. Water is especially harmful in that its presence in the delicate passages of the high pressure pump will cause rust which may ruin the very costly fuel injection system. The best way to avoid water in the fuel is to keep the fuel tank nearly full at all times. This reduces the air space in the tank, which cuts down on condensation. A water separator which should be periodically checked and drained when necessary, is also provided.

Diesel fuel stabilizer also works, is highly recommended, and can be obtained from your local fuel dealer.

When filling the fuel tank, care must be taken not to overfill it. This will result in excess fuel being expelled out the vent hose and into the ocean which is illegal. Care must also be taken to see that the fuel fill cap is replaced securely so that no water will leak into the tank.

Fuel drawn from a cool underground tank will expand when placed in the warmer ships fuel tank. Therefore the tank should only be filled to 95% of capacity to allow for expansion.

Diesel fuel while less volatile than gasoline is still explosive and extreme care should be taken while fueling or working on the fuel system. Never allow a mechanic to use ether as a starting aid. Ether can cause over pressurizing of the small cylinder on an auxilliary diesel.

7.5 Shafting

All CD-33's are fitted with 1" diameter bronze "Tru Shaft" propeller shafts. The propellers require a standard tapered SAE bore and are secured with one 3/4" nut, a Perry Nut zinc and a 1/8" cotter pin.

Alignment is very critical and should be checked carefully several times the first year and at the beginning of every season. Alignment can only be accomplished in the water, with the rig tuned. All engine mounts are adjustable up and down and athwartships. It is mandatory that the flexible coupling, if fitted, be removed when checking alignment. A common problem is the installation of a zinc between the propeller and the hull which prevents the alignment from being checked. To eliminate this problem a "Perry Nut" zinc is used. This zinc is used in place of the propeller nuts and can be ordered from Perry's Boat Harbor and Drydock, Isleton, California 95641. The nut is 3/4" with 10 threads to the inch and a 1-3/4 hub diameter.

Alignment is checked by mating the two metal coupling flanges together by hand and measuring the gap between them with a common automotive feeler gauge around the entire periphery. There should be no more than .002" gap anywhere.

7.6 Maintenance

Owners should refer to the engine manual for recommended maintenance. Daily checks should be made on the oil levels and fuel level. Particularly important is that the engine mounts and coupling bolts be checked often to see that they remain tight. Periodically it is a good idea to go over the entire engine with a set of wrenches tightening all bolts. Care must be taken not to overtighten and strip bolts and particular care must be taken on bolts that require certain torques such as head bolts. Engine vibration loads may have been experienced during shipment over the roads. Beyond the above, the engine itself should be kept clean and dry, and the fuel fresh, water free and dust free. The oil and filter should be changed often and the two fuel filters changed at least annually.

7.7 Winterization

Winterization is best left up to your storage yard. If you do it yourself, you should follow the instructions in the engine manufacturer's owner's manual. The major problem that can arise during winter layup is the danger of the engine water freezing. This can be prevented by either draining the water completely out of the engine and exhaust system, or by treating this water with antifreeze. Refer to the label for the proper mixing instructions for the degree of protection required in your locale. If the antifreeze system is used, it is mandatory to remove the thermostat to insure that water enters all areas of the block.

Chapter 8

PRESSURE WATER SYSTEM

Your yacht is equipped with an automatic demand type fresh water system. In use, it is quite similar to a typical home water system in that no switches need be turned or pedals pushed in order to get water.

The system is activated by a circuit breaker on the D.C. Panel. Once the system is switched on, the pump maintains a pre-set pressure at all times. When you open one of the faucets, the slight decrease in pressure which results is sensed by the pressure regulator built into the pump. The pump starts and runs until the faucet is shut. The pressure then builds back up and the regulator shuts off the pump.

Three water tanks feed the system: a starboard tank of 30 gallons under the main cabin berth, a bow tank of 24 gallons and a quarter berth tank of 24 gallons. All three tanks enter a common manifold under the galley sink. The tanks enter from above and each is fitted with a bronze shut off valve. Note: only one valve at a time should be open to prevent the syphoning of water between the port and starboard tanks in extreme conditions and to prevent air from entering the system from empty tanks.

Coming off one side of the manifold through a valve is the line leading to the manual galley pump. This pump is intended for use only when there is a power loss or mechanical difficulty with the electric pump. The valve at the manifold should be kept closed when the pressure pump is being used so that the electrical pump won't try to take its suction back through the hand pump and introduce air into the system.

Coming off the other side of the manifold is the line leading into the Parr #36400-0000 strainer and then the Shur Flow #220-21334 pump. The water leaves the pump at 35 PSI and goes to a "T" fitting. Here the cold and hot water systems separate.

On the hot side of the "T" fitting there is a check valve to prevent hot water from backing into the cold water side and a manual shut off valve used to isolate the hot water system for trouble shooting and safety purposes. From here the water goes into the hot water tank and back to a "T" under the galley sink. One side of the "T" feeds the galley sink and the other the head sink with no fittings in between. The cold water leaves the first "T" and passes back to a second "T" under the sink, and then on to the two sinks with no intervening fitting between the faucets and "T".

Start-up varies depending when your boat was shipped from the factory. Boats shipped between April 15th and September 15th do not

have antifreeze in them while the boats shipped September 15th through April 15th do.

On boats which have antifreeze in them the valve leading into the hot water side of the system was kept closed and only the cold water side of the system was tested here at the factory. This water should be flushed out and then the hot water side filled. The antifreeze used is safe for potable water systems and made by Sudbury Laboratories here in Massachusetts. Be certain the hot water tank is completely filled before turning the 110 volt heating element on or it will burn out the element. Also be careful not to accidentally activate the high temperature, high pressure relief valve which projects out from the side of the tank. Once the lever arm has been pulled, the valve will not reset and it must be replaced.

To activate the water system, fill up the tanks and open one valve on the manifold. We suggest you run the pump and open the cold water side of both faucets until a steady flow of water comes out. Close the faucets and repeat on the hot water side. You must be sure to eliminate any trapped air from the system or the pump will cycle rapidly or never shut off.

We hope that we have found any problems here at the plant but always check the clear hose where it goes into the pump for air bubbles flowing in the line. If air appears you must find its source, i.e. a leaking connection, leaking strainer, faulty manifold, or an empty tank.

Also, periodically check for a leak in the pressure side of the system. One tip off that something is leaking is the pump coming on at times when no faucet was opened. This signifies a loss in pressure which a leak would cause.

Chapter 9

HEAD SYSTEM

Refer to the head manufacturer's instructions on use of the marine toilet. It is recommended that a minimum amount of flushing water be used on each cycle to maximize the capacity of the holding tank. There is a deck pump-out fitting conveniently located on deck from which your marina can pump out the tank.

Government regulations require all U.S. yacht manufacturers to install a holding tank system or approved waste treatment system to prevent pollution. Early models were equipped with a 24 gallon polyurethane holding tank under the v-berth, while later models are fitted with a 36 gallon fiberglass holding tank built into the keel cavity. The plumbing of these units is basically the same.

All tanks have a 3" access cover on the top for inspection and clean-out. The use of deodorizing chemicals as sold for recirculating toilet systems is recommended to control odor. All tanks are fitted with a deck pump out plate from which your marina can pump out the tank.

The tank and head should be winterized by cleaning and treating them with a "Winterguard" type antifreeze. Winterguard is a non-toxic antifreeze which can also be used to winterize your fresh water systems.

If optional overboard discharge system is fitted, a "T" is placed in the deck pump out line. This leads to a vented loop, then to a whale gusher GP-10 manual diaphragm pump and then overboard through a seacock. With this system it is not possible to avoid using the holding tank. It is possible to use a divertor or "Y" valve in the system to isolate the holding tank completely where this is legal. Consult your local dealer for recommendations on this.

Chapter 10

SAILCARE

Sails should be protected from chafe by padding spreaders and other gear or by installing chafe patches on the sails themselves. Spreader and shrouds can chafe genoas and other overlapping jibs when those sails are sheeted in tightly and can chafe the mainsail when running before the wind. Topping lifts frequently chafe the leach of the mainsails.

Inspect your sails frequently and take care of chafed stitching or small tears before they become a major problem. A small ditty bag with some thread and a few sail maker's tools on board can come in handy and save you a few dollars.

Sails should also be protected from sunlight as much as is practical. Ultra violet light can break down the dacron in the sail cloth and stitching. Sails that are left furled on booms, jib club booms and forestays without suitable covers are most susceptible to this problem. Suitable sail covers are available from Cape Dory through your dealer.

Mildew is no longer the major concern that it was in the days of natural fiber sails. Your new sails should be dry before folding if for no other reason than to prevent the unsightly growth of this dark mold.

In order to retain the shape of your sails they should be folded after each use. In the case of the mainsail, outhaul tension should be relieved before folding the sail on the boom.

After the season, sails should be inspected and if necessary, serviced by a competent sailmaker. For appearance's sake stains should be removed and the sails washed gently with a mild soap and thoroughly rinsed.

Battens are thin wooden or fiberglass stiffeners inserted in the trailing edge of your boomed sails to support the outward curved leach. When inserting the batten, the thin edge goes into the batten pocket first. Battens, particularly wooden battens, can twist and warp if they are not kept flat. Keep this in mind when storing them. Battens should always be removed when the mainsail is furled.

Chapter 11

INTERIOR MAINTENANCE

Periodic cleaning is essential to keep the interior of your boat clean and bright. Choose sunny, breezy days for your boatkeeping chores as sun and fresh air are a great help in drying and airing interior cushions, etc. While you continue with the chores below; they also contribute to your enthusiasm for the task!

11.1 Cushions

Cloth covered interior cushions are made from several different materials depending on which color or style you selected. We, therefore, recommend that you either have the cushions dry cleaned or clean them with an upholstery shampoo of the spray foam type.

Vinyl interior cushions and cockpit cushions should be cleaned with a commercial vinyl upholstery cleaner. Follow the manufacturer's instructions regarding the use of these products. To prevent the growth of mildew beneath vinyl cabin cushions, elevate them when leaving the boat to allow air to circulate. Remove traps on boats so equipped so lockers will be aired.

11.2 Ice Box

The ice box on your Cape Dory is designed to drain water from melted ice through scuppers into the bilge. Because small food particles, juices from meats, etc. may also drain into the bilge, it is wise to use a name brand bilge cleaner in the bilge as needed or every three to four weeks (depending on how frequently you are using the ice box.). Follow the directions for use which accompany the product which you select.

Another alternative is to fit a plastic gallon jug on the end of the ice box hose. Periodically dump the melted ice out into the sink.

Food items should not be left for long periods of time in a closed ice box without ice. Spoilage, odors, mold and mildew will result. Plan to clean out your ice box (both ice and food items) at the end of each sail or cruise when you are leaving the boat for an extended period of time. Remove the ice box cover to permit thorough drying. Clean up any spillage of food in the ice box, etc. to prevent

blocking of the scuppers and drainage of this material into the bilge.

Clean the fiberglass interior surfaces of your ice box periodically with a sponge dampened with a water and bleach solution (this will help prevent mildew and odors in the ice box).

11.3 Ports

The Spartan ports fitted on your yacht are made of bronze, tempered glass and stainless steel. A neoprene gasket bedded in a contact adhesive is used to seal the port.

The hinge pins and port knobs should receive a light periodic oiling to combat any build-up of salt spray that may accumulate. The glass may be cleaned with any non-abrasive household glass cleaner.

Optional port screens are available which snap into place on the outside of the port. Do not use strong solvents on the plastic portions of the screen.

11.4 Curtains (optional equipment)

Generally the curtains supplied have a content of 77% cotton and 23% acetate and therefore should be dry cleaned.

11.5 Sinks

Stainless steel sinks may be cleaned with any stainless steel cleaner according to the manufacturer's instructions or with a non-abrasive cleaner and soft cloth or sponge.

11.6 Head

The plastic seat and vitreous china bowl of your head should be cleaned with a non-abrasive cleanser and sponge or soft cloth.

11.7 Interior Wood Surfaces

Rubbing the wood periodically with a fine bronze wool when oiling will help produce a smooth satin surface. Many excellent teak oils are available as well as other household products such as "Liquid Gold".

Some finishes are in a wax base such as the Minwax products. Repeated use of this type product builds up a finish that produces a very smooth surface. Care should be exercised, however, when using these products as oiling or varnishing at a later date may not be possible due to the layer of wax that has accumulated.

Make sure that adequate ventilation is provided when it is called for by a product's manufacturer.

11.8 Stoves

The manufacturer of the stove includes an owner's manual with the appliance. Read it carefully and make sure that everyone who uses the stove understands its operation. Remember alcohol fires can be extinguished with water or Type B fire extinguishers. Kerosene fires must be extinguished by smothering or with Type B extinguishers.

The following precautions refer to all types of stoves. Refer to the owner's manual for specific instructions.

1. Never leave lighted stove unattended.
2. Never leave a stove while it is still hot. Remember alcohol can burn with an almost invisible flame.
3. Always release pressure in the fuel tank when leaving.
4. Close fuel valve (if applicable) in case of emergency.
5. Exercise caution when priming burners. Improper priming is one of the most common causes of galley fires.

Maintaining Teak

Teak above deck on Cape Dory yachts has been sanded and oiled to a full golden hue before it leaves the assembly area. As it gets exposed to sunlight and drying conditions, the woods begin to take on a grey appearance that will eventually lead to surface deterioration of the wood. Teak which is ignored will eventually begin to split and grain will lift.

Contrary to what you may have heard, teak is not a miracle wood that is totally maintenance free. It is easy to maintain. There are a

number of excellent teak cleaning and sealing preparations on the market. We suggest that you ask your sailing friends (who have teak you admire) for their suggestions. (Many excellent teak cleaning and sealing products are not available nationwide, so use the best available in your area.)

The teak may also be varnished; put three to six coats on initially; plan to apply another coat at midseason, and a final coat prior to winter layup. Follow manufacturer's directions for the varnish which you purchase (use only quality marine varnish.)

11.9 General

Dirt, hair, etc. should not be washed into the bilge during any cleaning process as these may plug the bilge pump strainer and prevent it from functioning when needed. Use a dust pan to collect dirt, etc. when cleaning the cabin sole of your boat.

Raise covers of lockers when leaving the boat to permit adequate ventilation and prevent mildew should these contain moisture. Remove excess moisture which may have collected in lockers with a sponge.

Chapter 12

EXTERIOR MAINTENANCE

12.1 Gelcoat

The best protection for your gel coat surfaces is to clean and wash them with a good detergent regularly. You should also wax them twice a year with a good paste. Should your yacht ever have to be resurfaced or painted, for whatever reason, we suggest you use a wax that does not contain silicone. Silicone gets into the gelcoat and is almost impossible to remove, causing "fish eyes" when you try to paint over it. Do not wax non-skid surfaces.

Minor repairs of the gel coat surfaces may be done by the owner using one of the following methods:

Surface Imperfections: On imperfections that do not penetrate the gel coat, you may sand them out with #320 wet and dry sandpaper. Finish with 400 and 600 grit paper and hand buff with a fine rubbing compound.

Deep scratches and flaws: (exposed fiberglass) Thoroughly clean the damaged area with acetone to remove dirt, grease, or wax. Tape off the area around the flaw with masking tape. Thicken a small amount of matching gel coat with talcum powder or cabosil to obtain a putty-like consistency. When ready to apply the putty, thoroughly mix a small amount of hardener into the gel putty. A tablespoon quantity of gel putty will require one drop of hardener to cure into a hard plastic in mild temperatures. Some experimenting will allow you to adjust the amount of hardener to suit your needs. Over-catalyzing results in a rubber-like substance, never permitting a complete cure.

Apply the gel putty with a putty knife, filling the flaw slightly above the surrounding surface. Allow to harden. Sand and buff as previously mentioned for shallow scratches. Clean up hands and tools with acetone before putty hardens.

CAUTION: The clear hardener should be handled with great care. Flush skin or eyes with large amounts of water if accidentally splashed.

Be careful of discarding uncured, mixed gel coat material. Once hardener is added, a chemical reaction takes place that generates heat. Large quantities can become very hot. Submerge material in water until cured for maximum safety.

Non-skid imperfections: Repair of the non-skid is similar to that of deep imperfections only that you add trace amounts of non-skid grit

and dab the gel coat on with the end of a brush with short hand movements.

Spar

It goes without saying that removing the spar and storing it inside after the sailing season is over (northern climates only) is preferable to leaving the spar stepped or outside. Regardless of where you sail, the spar should be waxed once a season and inspected carefully.

All moving parts on the spar were treated with a Teflon lubricant when they were installed. At least once a season you should do the same.

Standing Rigging

Standing Rigging, the fixed rigging supporting your mast, should be inspected frequently to ensure trouble-free sailing.

New rigging will often form a thin layer of rust, especially at the terminal ends. This is caused by impurities surfacing when the wire is cold worked during manufacture. The oxidation should eventually stop forming and when it does the stain should be removed with an unchlorinated cleanser. If the rusting persists after several cleanings, contact your dealer.

Turnbuckles should be checked that there are sufficient threads exposed and that the cotter pins are in place and taped over.

Check the spreaders to be certain that they are angled upward with the angle between the upper shroud and the top of the spreader the same as the angle formed by the bottom of the spreader and the shroud. The spreader tip should be securely seized to the shroud and it all protected by chafing gear.

Once a month you should go aloft and check all shrouds, tangs, masthead assembly, etc. to be certain all bolts are tight and all cotterpins are in place.

Rigging that has split strands of wire or cracked swage fittings should be discarded and replaced.

12.2 Running Rigging

Because of the recent advances made with pre-stretched dacron line and the age old problem of fish hooks forming in stainless halyards after one season of use, your boat is equipped with pre-stretched halyards. They have gone around the world and received acclaim from almost every notable offshore cruising man.

Periodic inspection of the running rigging will point out any areas of excessive chafe. Often the offending item causing the chafe can be corrected. Otherwise, one way to extend the life of the rigging is to either end for end it or move the shackled end it in up a foot or so

every year to move the point of wear away from the sheave, winch turning block etc. Only experience will dictate when they need replacement.

Lifelines, Pulpits and Stanchions

Lifelines, like standing rigging, should receive periodic checks. The terminal ends should be engaged properly in the barrels of the turnbuckles and the lock nuts tight. As the lines stretch, the slack should be taken up. Check all swaging for dents or cracks.

Check pulpits and stanchions for cracks, dents, and cracks in the weld. Check that the bases are tight and properly sealed.

Periodically, some of this stainless hardware shows signs of rusting as mentioned in the standing rigging section. If after a period of time the rusting continues, contact your dealer.

Winches and Blocks

The winches installed on your yacht are the finest available. Most problems occur when a proper maintenance schedule is not followed. It is important that your winches be cleaned and inspected at least twice a season or after a two or three week offshore passage. We recommend a high density grease and not an oil for the required lubrication. Check to see that all bolts holding the winch down are tight.

Blocks require little maintenance except periodic washing in fresh water and a light oiling or spraying with a silicone lubricant. Check all aluminum T tracks for signs of lifting or loose fasteners.

Chapter 13



RIGGING INSTRUCTIONS

SPARTAN MARINE PRODUCTS INC.
160 Middleboro Avenue
East Taunton, Mass. 02718 (617) 823-6776

IMPORTANT: Read instructions carefully before rigging your sailboat.

- 1.) Hold each coil of wire firmly and carefully, unwind with extra precaution avoiding injury from retracting rigging ends that are under tension. (Take care not to crimp the wire while uncoiling.)
- 2.) Leave I.D. tags on shrouds and stays to avoid confusion till completion. A helpful hint is to document wire numbers on your rigging kit list enclosed and retain in a safe place for future reference.
- 3.) Attach each piece to its respective location on the mast making sure to insert proper clevis pin and locking it with a cotter pin. (The mast lights should be checked before the mast is installed so that defective bulbs can be replaced easily.)
- 4.) When all rigging is properly located p/identification tags and turnbuckles are in place, make sure again that each turnbuckle is stationed with a corresponding clevis pin and locked in place with a cotter pin.
- 5.) Take note on the maximum dimension your turnbuckle should be opened with turnbuckle barrel equally located between threaded sections.

Measuring from the center of the clevis pin to the top of the swage, the maximum "Y" dimension should be as follows:

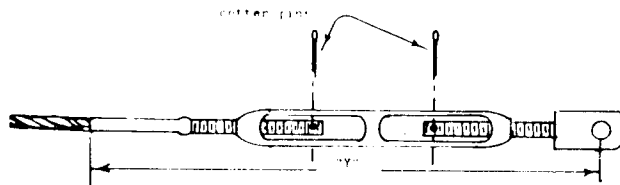

	"Y" DIMEN.	WIRE SIZE
C-33/36 lowers.....	15 3/4"	1/4"
C-36 staysail.....	15 3/4"	1/4"
C-33/36 uppers, backstay, forestay.....	19"	9/32"

- 6.) Tighten every shroud and stay so that they have the correct tension and the mast is stayed plumb with no bends or curves in it. Insert cotterpins in the threaded studs and spread them to prevent them from falling out. Tape the cotter pins with chafe tape to prevent lines and other objects from becoming snagged on them.
- 7.) Because of the manufacturing process used in fabricating the wire used on the shrouds and stays, you will experience a certain amount of stretch in your rigging after sailing in the first rough weather of the season. Repeat the above procedure to be certain that your mast is always well tuned.
- 8.) Finally fill out enclosed registration form and return a duplicate copy to Spartan Marine promptly.
- 9.) **ATTENTION: SKIPPER**
 - a.) Please note: When rigging and mast are properly assembled and installed, avoid taking any risks that would compromise the rigging assembly for purposes other than what it was designed for. Exercise good judgment.
 - b.) Frequent checks for excessive rigging wear and weak areas should be made to ensure maximum safety. Especially check for chafing. Sails and running rigging can be easily chafed.
 - c.) Worn rigging or any pieces that are in question should be replaced as soon as possible. (For further clarification consult your Dealer on any pieces in question.)
 - d.) Your sparsset also demands attention and periodic checks, to ensure that all pieces are secure and free from wear.

13.1 Stepping the Spar and Tuning

Your yacht, having a keel stepped spar, has an adjustable mast step. It also has a mast collar utilizing wooden wedges and a mast pin. The mast pin is provided so that if custom hardware is added, for instance, to lead halyards on reef lines aft, the verticle pull placed on the deck won't tend to lift the deck away from the bulkheads. This type of device is not required on deck stepped spars but it is a very desirable feature on keel stepped spars.

We recommend that you align your mast fore and aft, centering the spar in the mast collar. Wedge the spar lightly but don't install the collar pin until after your first sail. Then alter the rake if required and check the spar firmly and install the mast collar pin. Be sure to tighten the mast step bolts securely when final tuning is done.

The fore and aft alignment of your mast can be checked by comparing it to a vertical structure such as a radio tower, chimney, etc. It can also be checked by hanging a heavy object on the main halyard on a calm day and observing the rake.

Upper shrouds should also be tightened equally and have about an inch of "give" to them. To check the spar to be certain that no athwartship rake is in it, get your boat on her lines and using the main halyard, measure the distance from the masthead to the aft lower shroud on both sides. If the distance is between 1/2" of being the same, you know that the mast is plumb. It should also be approximately in the center of the mast collar. Forward lower shrouds should have one to two inches of "give", and the aft lowers slightly more.

Under no circumstances take up the rigging to bar tight tension. Both the mast and the boat can be severely damaged by excessive tension.

Fine tuning of the rig can be completed after the boat has been sailed, and may have to be done again after the boat has been out in strong winds. When sailing, it is important that the mast remain straight and as nearly in column as possible at all times. While sailing close hauled, sight up the mast track and note any mast curve. Does the mast appear to be falling off to leeward at the top, or does it hook upwind? Repeat this procedure on the opposite tack.

If the masthead is falling off on both tacks, the forward lower shrouds are too tight and the upper shrouds are too loose. If the masthead hooks to windward, the upper shroud is too tight in relation to the lower on the same side. When sailing to windward, the forward lower shrouds bear a greater load than the after lower shrouds; however, the after lower shrouds on the windward side should never be loose. All shroud tuning should be done from the leeward side. If the rig seems to be equally balanced when you begin, duplicate every half turn from side to side.

Check to see that all cotter pins or rings are in place and that all sharp edges are taped.

Chapter 14

WINTERIZING

Winterizing your yacht is a relatively simple procedure. We are assuming that the boat will be dry stored in the following instructions. If you should decide to wet store your boat, be sure to take adequate precautions against water freezing in the engine and plumbing systems on your boat.

Blocking the hull

A good boat yard is, no doubt, expert at properly supporting the hull. Check to make sure that the weight of the hull is resting on the keel. The purpose of cradle bulkhead or poppets is to balance the boat in an upright position, not to bear the weight of the boat.

Before hoisting out, show the boat yard the profile of the hull so that they will know how to position the crane or straddle the hoist straps. The usual locations for the straps of a typical marine lift are just forward of the rudder heel bearing and in the hollow of the fore foot.

Cockpit Scuppers

Flush with fresh water and leave seacocks in the open position so that hoses will not fill with rain water and freeze.

Ice Box

Clean ice box thoroughly and leave open.

Stove

Clean stove thoroughly including burners. Release pressure in fuel tank and leave tank empty.

Electrical System

Remove batteries from boat and store in a warm dry location off a cement or stone floor. They should be completely charged before storing or left on a trickle charge.

The balance of your electrical system requires little maintenance. If you wish, each bulb can be removed and the light fixtures given a spray of water dispersant such as "WD40", "CRC", or similar products. The main switch and fuse panel can also be treated this way to minimize corrosion.

Propeller

Examine the propeller for any damage or nicks. If evidence of either is apparent, have the propeller removed and trued.

Head

Follow manufacturer's directions closely. Remove any water to prevent from freezing. The holding tank should be empty when the yacht is laid up for the winter. If possible, flush the tank with a mixture of non-toxic antifreeze and water prior to hauling. This will assure a minimum of problems when the system is reactivated in the spring.

Water System

Pump tanks as dry as possible, then add a non-toxic water system winterizer that your local marine hardware store will recommend. (Caution: do not use antifreeze or other poisonous substances.) Pump this solution through the entire fresh water and drain system.

Engine

Follow the instructions in the engine owner's manual supplied by the manufacturer and read the section in this manual.

Disconnect engine cooling water intake to make sure that no water remains in the line. Reconnect line and secure hose clamps. Remove the drain plug in the muffler and drain.

Fuel Tanks

The best way to store a fuel tank is empty. Partially filled tanks invite condensation. Completely filled tanks leave you with old fuel in the spring and possible gum deposits. Much has been written lately on this subject and new products are being developed to prevent gum deposits. Keep informed and consult your dealer or shipyard for recommendation.

Covering

It is far better to store a boat under cover than to leave it open to the elements. The teak trim will fare far better during the winter and the boat will not be subject to the pressure of freezing water, a common cause of gel coat stress cracks. If your boat cover is durable, open a couple of ports to allow air to circulate below decks.

ALIGNMENT INSTRUCTIONS

NOTE: Coupling must always be removed before aligning shaft.

STEP 1

Disconnect reverse gear and propeller shaft flanges, being careful to support the dead weight of the propeller shaft. Leaving bolts loosely connected aids support of propeller shaft.

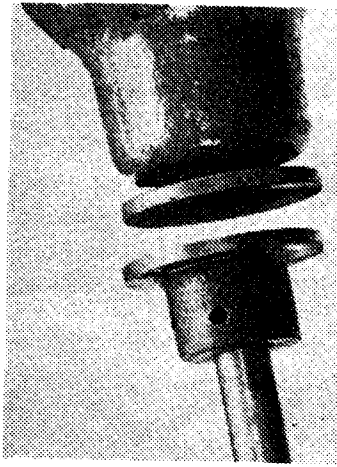

STEP 2

Check alignment of propeller flange to reverse gear flange by using a feeler gauge around entire perimeter of the coupling. Shim engine to compensate for any misalignment. (Industry norm for misalignment is .002").

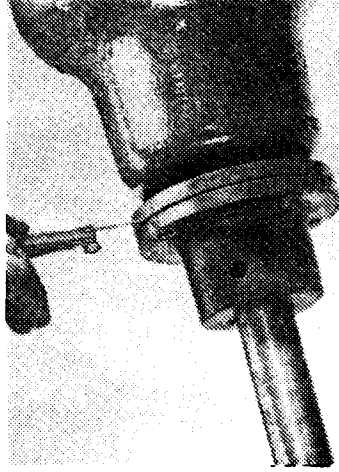

STEP 3

Install Disc Drive to the reverse gear flange by mating the pilots. Rotate Disc Drive to align socket gear bolts with bolt holes of reverse gear flange. Install socket gear bolts. Use lock washers and nuts, if necessary. Then tighten.



STEP 4

Slide propeller shaft with flange forward so pilot on the propeller flange mates with the pilot on the Disc Drive. Insert hex bolts with lock washers into threaded inserts of Disc Drive and tighten. Turn shaft by hand to determine runout. Use a dial indicator for accuracy.

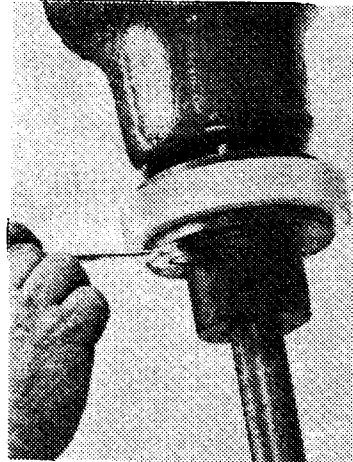

STEP 5

Re-check bolt tightness after ten to fifteen hours of operation. The use of a small amount of waterproof grease on all fasteners is recommended to facilitate disassembly, when necessary.

COMPLETED
INSTALLATION

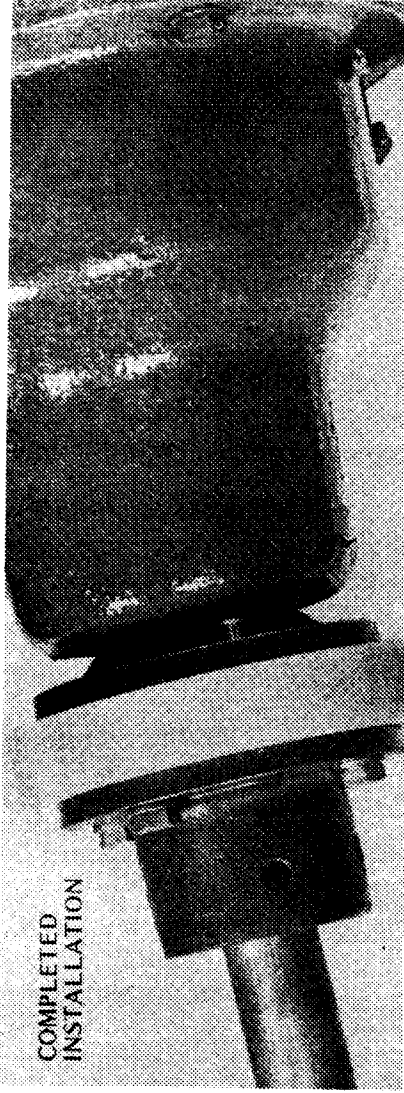

The Disc Drive flexible coupling is used on the Cape Dory 28, the Cape Dory 33 up to hull No. 39 and the Cape Dory 36 up to Hull No. 84. When tightening the hex bolts in step 4, please remember to do so at 180° intervals. Also, do not overtighten as this can cause the flex coupling to deform. (These alignment instructions were reprinted with the permission of Globe Rubber Works of Rockland, Mass.)

Chapter 15

SAFETY

Federal regulations require certain safety equipment to be onboard your boat (personal and throwable floatation devices, fire extinguishers, horn, whistle, etc.). Know what equipment is required and have it aboard and properly stowed before you cast off for the first time.

In addition to the equipment requirements outlined here, the U. S. Coast Guard can provide additional information and answer your questions. It is highly recommended, although not required that, certain additional items be kept aboard. This list is not complete, you should have all USCG required gear.

1. An anchor of appropriate size and design and rode of good quality, appropriate size and length.
2. First-aid kit.
3. Compass.
4. Paddle.
5. Flashlight.
6. Up-to-date charts of the waters to be sailed.
7. Flares.

Fire extinguishers are not standard equipment on your Cape Dory; they are to be provided by you, the owner. Fire aboard any boat is a real serious hazard. It is important to take adequate precautions against fire and to be well prepared to extinguish one quickly and thoroughly should it occur. For this reason, U. S. Coast Guard approved fire extinguishers of the appropriate type and size (check U.S.C.G. regulations) should be installed immediately.

The permanent location of fire extinguishers where they are easily accessible (near areas where fires most likely are to occur - engine, fuel tanks, and galley) is important. They should not be located where fire may prevent their use. At least one extinguisher in a cockpit locker (reachable from outside the cabin) and one extinguisher installed below is a minimum.

Charts

There is no substitute for complete and up-to-date charts.

The Coast Guard is constantly making improvements on the aids to navigation which change buoy locations, numbers, configurations, etc. These changes are reported in the respective Coast Guard District's Local Notice to Mariners, and are on display at all NOAA Chart Distributers. Before embarking on any trip outside your home port, make certain that you have the latest editions of the chart, and that they are fully corrected.

Fueling

Appropriate safety precautions are important before, during and after fueling. Before fueling the first time, be familiar with the instructions provided by the engine manufacturer.

1. Fuel docks should be approached at reasonable speed without wake. Observe posted speed limits and instructions. Be considerate of others using the docks, and watch for a dockmaster or hand who may give you instructions. Maintain control of your boat at all times and have your dock lines ready for use before you approach in the event that these are unavailable at the dock.
2. Use bow, stern and spring lines to properly secure your boat.
3. Close and secure all hatches and ports.
4. **FORBID SMOKING** while taking on fuel on or near fuel docks. Completely extinguish all smoking materials well in advance of approaching the docks; do not recommence until you are well clear of it after fueling and conditions aboard are safe to do so.
5. Extinguish any other open flames aboard and see that all equipment (e.g. engine, stove, cabin heater, radios, and lights - both lanterns and electrical lights, etc.) which may generate heat or sparks of any kind are turned OFF...Turn off all switches for branch circuits so that there are no live electrical circuits. Main switch should also be turned off AFTER engine is stopped (to avoid alternator damage).
6. If possible, crew members not involved in fueling should leave the boat.
7. An adequate fire extinguisher (USCG approved for Class B fires) should be readily available in case of emergency.
8. Remove fuel fitting. Be certain that you are putting fuel in the fuel tank. Note the approximate amount required to fill the tank by looking at the fuel level gauge if one is in the tank.
9. Be certain (double check) that you are taking on the appropriate fuel, diesel not gasoline. Errors of this type do occur and will result in serious engine damage if not immediately detected and corrected.
10. Sometimes if you are in an unfamiliar area you may want to first take a sample of the fuel you plan to pump on board for a visual and smell check to insure that it is diesel and not gasoline.

11. Maintain contact between the nozzle of the fuel hose and the fill pipe rim to prevent generation of static electricity sparks.
12. Fill slowly to about 95% of capacity; do not overfill (allowance must be made for thermal expansion of fuel without overflow.)
13. Replace and secure fill fitting after fueling. Carefully clean any spillage. Check fuel tank vents at stern for overflow. Check below decks and in the bilge for fumes or leakage. If fumes or leakage are present, adequately ventilate and clean areas completely before proceeding.
14. Open all ports and hatches fully for ventilation.
15. Do not fuel during electrical storms; avoid fueling at night or in rough water, except in emergencies when extreme caution must be exercised.
16. Note the diesel fuel is flammable; handle it accordingly in a cautious manner.

15.1 Weather Forecasts

The U.S. Coast Guard is in the process of discontinuing the display of weather signals at its stations and other locations along all coasts in favor of the NCAA weather broadcasts which are continuously broadcast on weather channels WX-1 and WX-2 (162.40 MHZ and 162.55 MHZ).

Good seamanship requires attention to the weather forecast before leaving port, and while you are sailing. Tune in to VHF weather, and make it a practice to check the broadcast on a regular basis in case there are changes in the forecast.

15.2 Boating Safety Organizations

Every sailor was once a beginner. Very few were born into sailing families and learned at their parents' knees. Therefore, it is to everyone's benefit that there are several fine non-profit organizations that are ready to teach interested persons everything from basic seamanship and piloting to celestial navigation.

Two of these organizations are:

- United States Power Squadrons (U.S.P.S.)
- United States Coast Guard Auxiliary

Vendor List

In the interest of faster and more efficient service, Cape Dory developed a list of the more important equipment and manufacturers produced this list so that the Cape Dory owner will be able to go direct to the original vendor for replacement parts, but we still want you to feel to call us here at the factory for any additional information.

<u>Item Description</u>	<u>Manufacturers part #</u>	<u>Vendor</u>
<u>BLOCKS:</u>		
Top lift block	02-14	Schaefer Marine
Jib Track Blocks	08-91	Schaefer Marine
Main Traveler Block	SK43-83	Schaefer Marine
Main Sheet Boom Block	07-03	Schaefer Marine
Boom Block	07-13	Schaefer Marine
Reef Cheek Block	30-11	Schaefer Marine
Top Lift Cheek Block	03-30	Schaefer Marine
<u>BOTTOM PAINT:</u>		
Antifouling Blue or Brown	Epoxy Cop	Rule Industries
Boot Top Dado Dark Brown	246	Interlux
Boot Top Seminole Red	593	Gloucester Paints
<u>ELECTRICAL:</u>		
Battery - 12 volts - 75 amps	5124M	Bay State Battery
Dome Lights (bulb 12V15CP)	10-1252	Bass Products
Single Swivel (bulb GE1142)	10-2162	Bass Products
Double Swivel (bulb GE1142)	10-2222	Bass Products
8 watt florescent (GEFT5-CW)	10-1872	Bass Products
Panel		Lorco Marine
Port & Starboard Lights	33512-302	Ahlemann & Schlatter
Stern Light (bulb 12V10W)	33509-002	Ahlemann & Schlatter
Mast Light (GE212 & 12V6W)	S-163	Spartan Marine
<u>ENGINE:</u>		
Universal Diesel Model 30		Apponaug Harbor Mar
Impellor Kit	298410	Apponaug Harbor Mar
V Belt	204002	Apponaug Harbor Mar
Fuel Filter	298854	Apponaug Harbor Mar
Oil Filter	298852	Apponaug Harbor Mar
Injector	298787	Apponaug Harbor Mar
Glo Plug	299839	Apponaug Harbor Mar
Exhaust Flange Gasket	298600	Apponaug Harbor Mar
Thermostat Housing Gasket	298843	Apponaug Harbor Mar
<u>PORTS & HATCHES:</u>		
Medium Hatch	139-medium	Bomar, Inc.
Small Hatch	139-small	Bomar, Inc.
Bronze Oval Ports	P-560	Spartan Marine

<u>HEAD:</u>	HE HTP	Gross Mechanical
<u>HOT WATER HEATER:</u>		
Raritan	6E	Raritan Engineering
Spare Parts:		
Heating Element	WH1A	" "
Safety Valve	WH3	" "
Heat Exchanger	HE	" "
Thermostat	WH2	" "
<u>PEDESTAL:</u>		
5" Pedestal	335	Edson Corp.
Chain Assembly	775	" "
4" Upright Single Sheave	620	" "
4" Swivel Idler	711	" "
10" Quadrant	614	" "
#1 Wire Take-up Eye	618	" "
3/16 Wire Rope Clamp	665	" "
1-1/2 Self Aligning Bearing	629A	" "
Size 45 Shift and Throttle	816	" "
Size 456 Brake	6897	" "
Size 45 Guard	662	" "
28" Wheel	280-595	G.G. Schmitt
<u>PUMPS:</u>		
Manual Bilge Pump	Whale Gusher 10	Imtra
Pressure Water Pump	36950	Par Jabsco
Galley Foot Pump	GP-0507	Imtra
Head Foot Pump	GP-46A8	Imtra
Counter Top Pump	37220-0010	Par Jabsco
Electric Sump Pump	Rule 750	C.E. Beckman
Sump Pump Switch	Rule 49	C.E. Beckman
or		
Electric Sump Pump	36251-0000	Par Jabsco <i>Shapiro - Avakim</i>
Sump Pump Switch	44960-0002	Par Jabsco <i>92805 Co.</i>
<u>TRACKS:</u>		
Genoa Tracks	1-1/4" x 3/16" x 10'	Spartan Marine
Jib club traveler	1" x 1/8" x 4	Spartan Marine
<u>TRAVELERS:</u>		
4' Track	1169	Nicro Fico
Car	1165	" "
Track Stops	1176	" "
Adjustable Stops	1177	" "
Bridge Assembly	B-129	Spartan Marine
<u>SHIFT & THROTTLE CABLES:</u>		
8' Throttle Cable	3300 BC	Northwest Controls
10' Shift and Throttle	3300 BC	Northwest Controls

Note: be sure to check actual length on your boat before ordering.

VENTS:

3" Low Vent	108836	Nicro Fico
3" Vent Deck Plate	10863DW	" "
3" Vent to Hose Adaptor	10863HA	" "
3" Hi Vent	10923C	" "
4" Hi Vent	10964C	" "
4" Chrome Deck Plate	10864DC	" "

WINCHES:

Mainsheet Winch	16 B	Lewmar	Marine
Jib Sheet Winch	7 B	"	"
Yankee/genoa Sheet Winch	40 B	"	"
Main Halyard Winch	7 C	"	"
Yankee/genoa Halyard Winch	8 C	"	"
Staysail Halyard Winch	6 C	"	"
Reefing Winch	6 C	"	"

VENDOR ADDRESSES

Ahlemann & Schlatter/ Browning Marine	P.O. Box 806	St. Charles,	IL	60174
Apponaug Harbor Marina	21 Arnolds Neck Drive	Warwick,	RI	02886
Bass Products	P.O. Box 901	Marblehead,	MA	01945
Bay State Battery	70 Shawmut Road	Canton,	MA	02021
C.E. Beckman	11-35 Commercial St.	New Bedford,	MA	02740
Bomar	Box 314, So. West St.	Charlestown,	MA	03603
DiPetro Kay Corp	914 Cromwell Avenue	Rocky Hill,	CT	06067
Edson Corp.	460 Industrial Park Rd.	New Bedford,	MA	02745
Essex Machine Works	West Avenue	Essex,	CT	06426
Gem Products	369 Blanding Blvd.	Orange Park,	FL	32073
Gloucester Paints	P.O. Box 860	Gloucester,	MA	01930
Gross Mechanical Lab.	7240 Standard Drive	Hanover,	MD	21076
Imtra	151 Mystic Avenue	Medford,	MA	02155
International Paint Co.	Morris & Elmwood Ave.	Union,	NJ	07083
Lewmar Marine	23 Broad Common Road	Bristol,	RI	02809
Lorco Marine Electric	715 Perimeter Road	Manchester,	NH	03032
Mack Boring & Parts Co.	Rte 22 West, Engine City	Union,	NJ	07083
Merriman-Holbrook	301 River Street	Grand River,	OH	44045
Nicro Fico Corp.	2065 West Ave. 140th	San Leandro,	CA	94577
Northwest Controls	Vernfield Village	Harleysville,	PA	19438
Par Jabsco Products	1485 Dole Way	Costa Mesa,	CA	92626
Raritan Engineering Co.	1025 No. High Street	Milville,	NJ	08332
Schaefer Marine Products	Industrial Park	New Bedford,	MA	02745
Spartan Marine Products	160 Middleboro Avenue	E. Taunton,	MA	02718
Rule Industries	Cape Ann Industrial Park	Gloucester,	MA	01930

Shurflo

exakem

Shurflo

1-714-533-7700

CAPE DORY 33

L.O.A. 33' ½"
L.W.L. 24' 6"
Beam 10' 3"
Draft 4' 10"
Displacement 13,300 lbs.
Ballast 5,500 lbs.
Sail Area 546 sq. ft.
Designer — Carl Alberg

16.1 SAIL PLAN

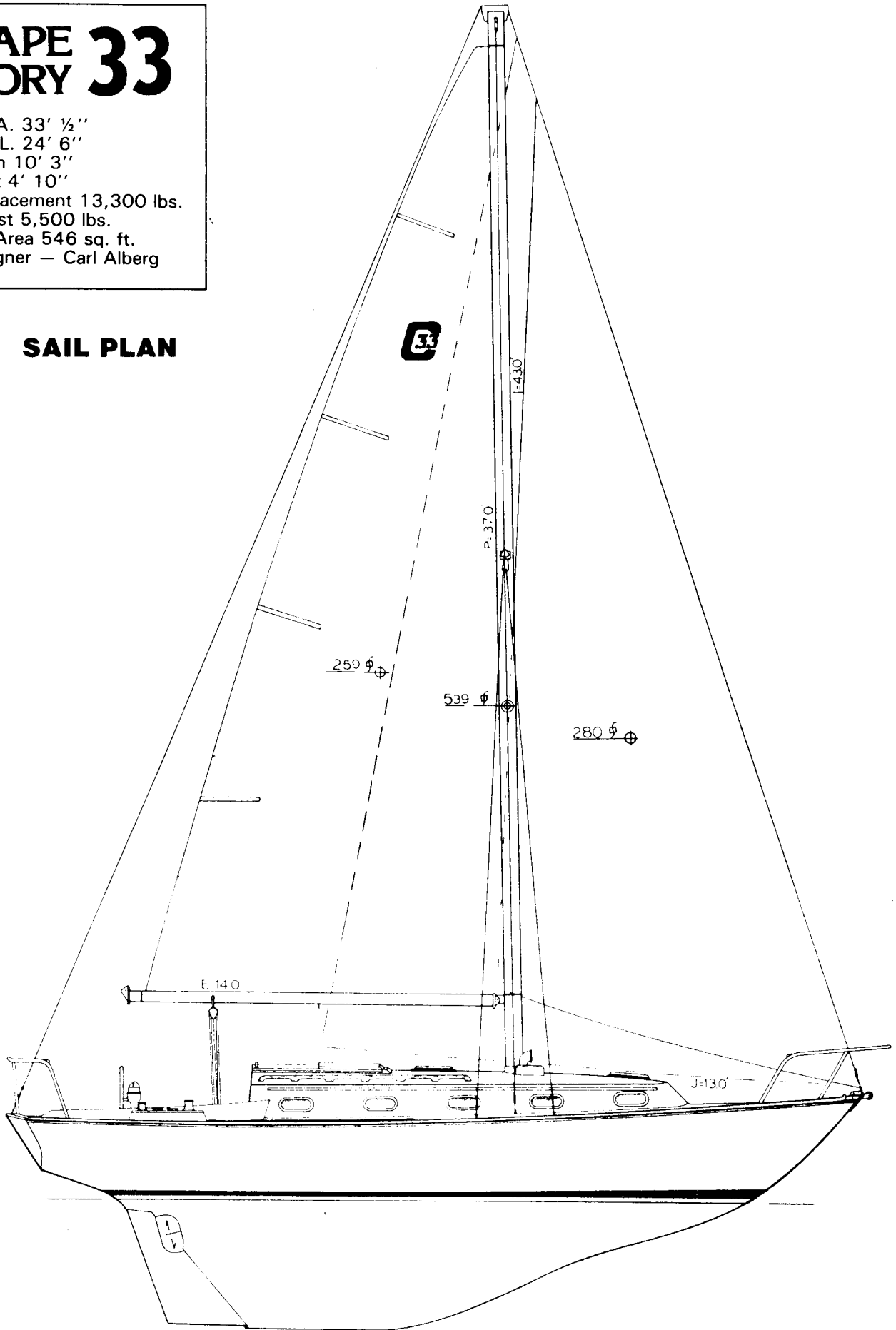

16.2 LAYOUT

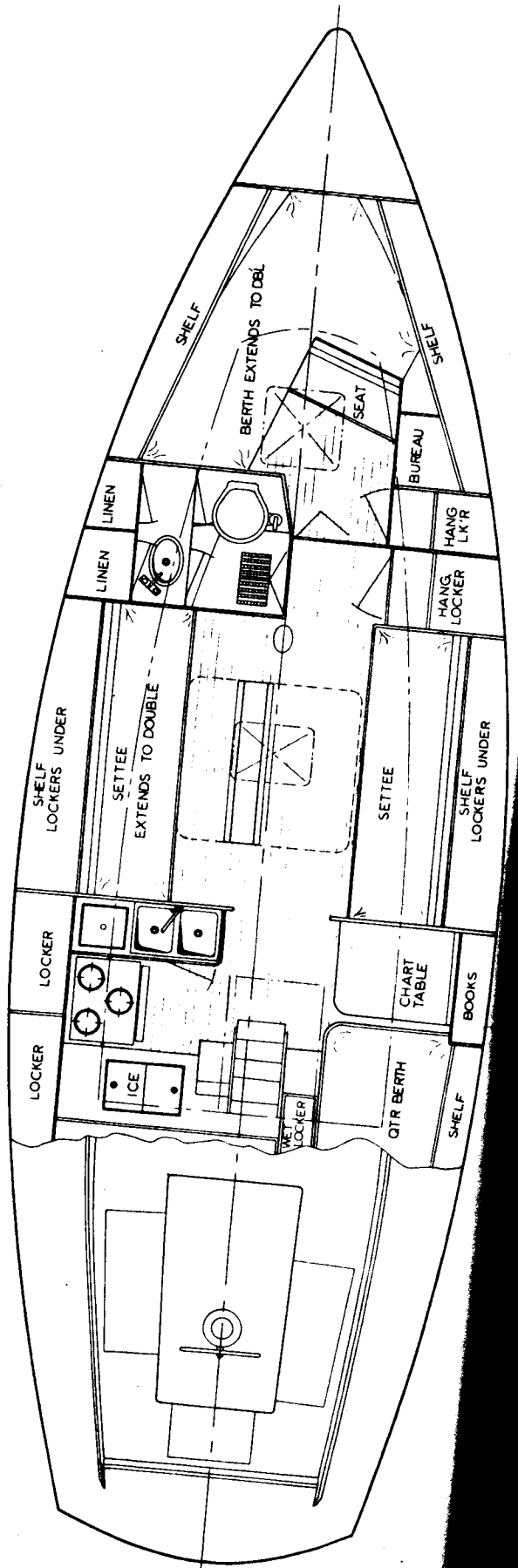
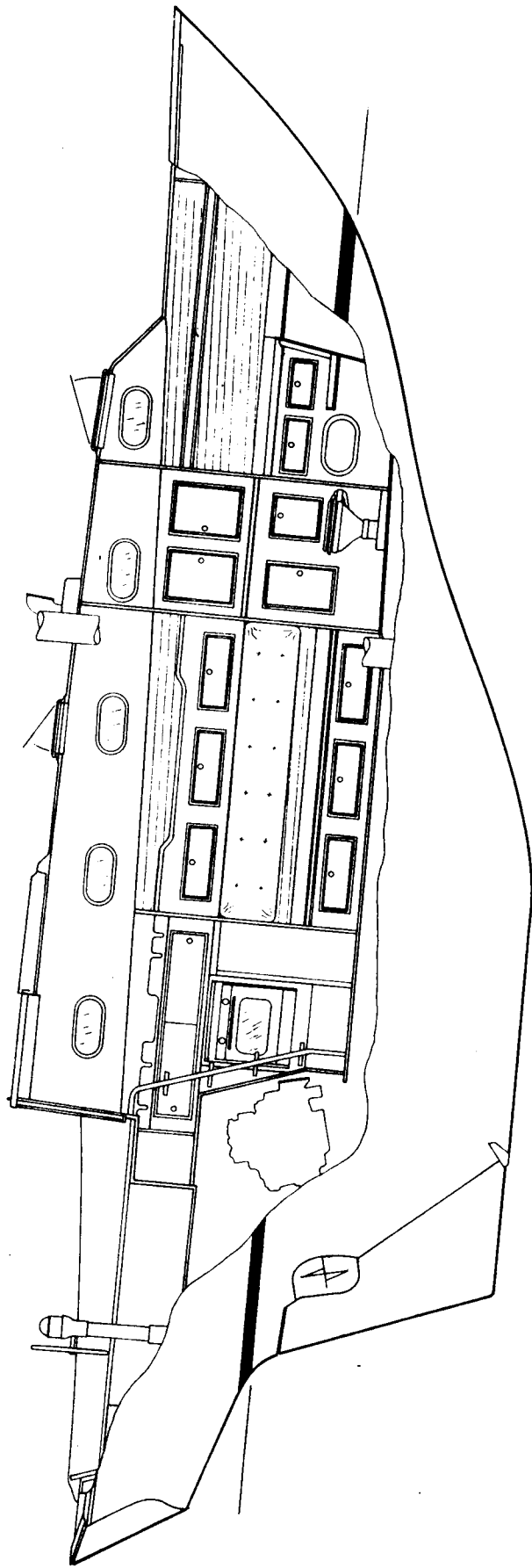

16.3 TECHNICAL INFORMATION

Hull Speed	6.63 knots (7.6 M.P.H.)
Ballast/Displacement	.42
L.O.A.	33' 1/2"
L.W.L.	24' 6"
Beam	10' 3"
Draft	5' 0"
Sail Area	546 S.F.
Displacement/Length	380
SA/Displacement	15.6
Lateral Plane/Rudder	11.1%
Lbs. per inch Immersion	810 lbs.
Sail Area/Wetted Surface	2.24
Beam/Length	.31

16.4 STANDING RIGGING

Forestay	9/32" 1 x 19 wire approx. 44'
Back stay	9/32" 1 x 19 wire approx. 46-1/2'
Upper Shrouds	9/32" 1 x 19 wire approx. 42-1/2'
Fow'd & Aft Lower Shrouds	1/4" 1 x 19 wire approx. 23'

16.5 RUNNING RIGGING

Main Sheet	7/16 x 85' Dacron Braid
Jib Sheet	1/2" x 50' Dacron Braid - 2 each
Main Halyard	1/2" x 90' Pre-stretched Marlow
Jib Halyard	1/2" x 100' Pre-stretched Marlow
Top Lift	5/32 7 x 19 wire approx. 37'
Traveler Car Sheets	3/8 x 12' Dacron Braid - 2 each
1st Clew Reef	3/8 x 26' Dacron Braid
2nd Clew Reef	3/8 x 35' Dacron Braid
Opt. Genoa Sheets	1/2 x 70' Dacron Braid - 2 each

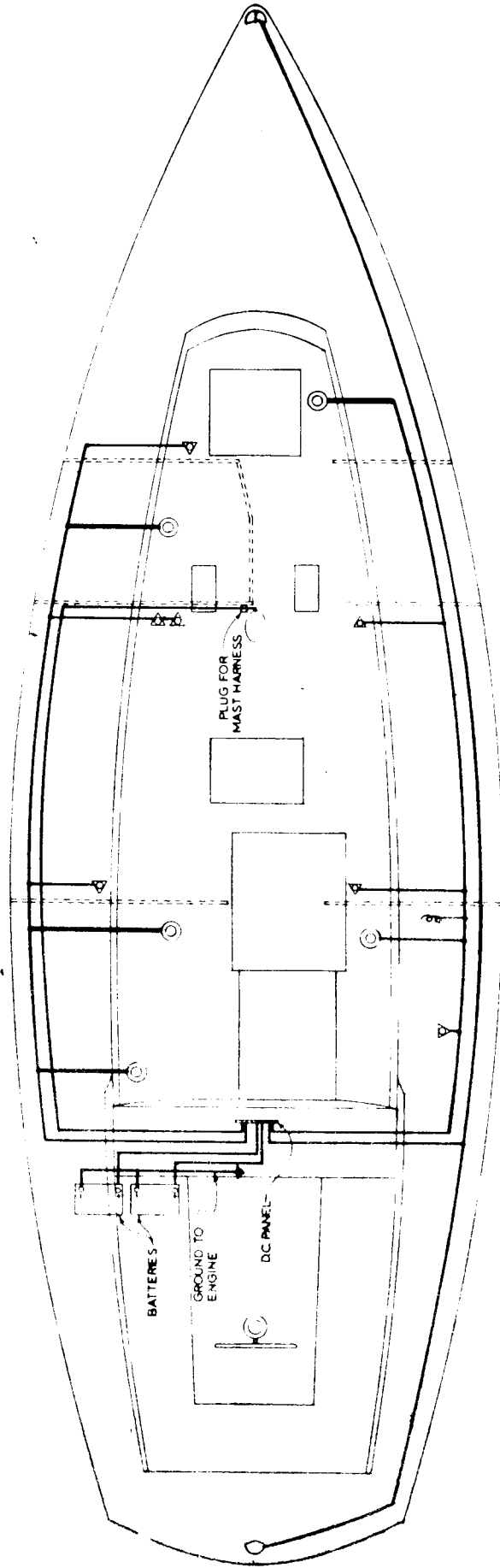

- ACCESSIBLE WIRING
- WIRES PERMANENTLY FASTENED TO UNDERSIDE OF DECK
- ⊙ DOME LIGHT
- △ BULKHEAD LIGHTS
- NAVIGATION LIGHTS

16.6 D.C. WIRING LAYOUT

16.7 A.C. WIRING DIAGRAM

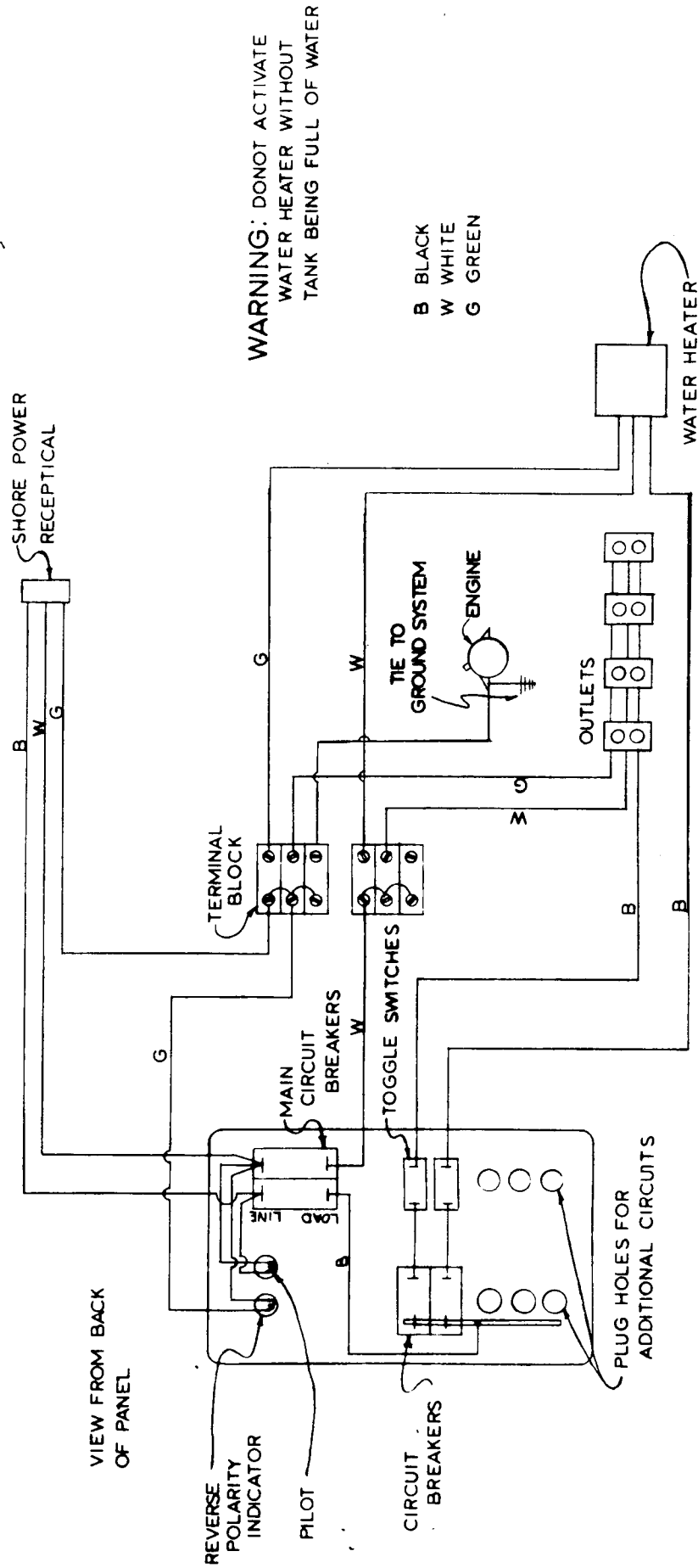

WARNING: DONOT ACTIVATE WATER HEATER WITHOUT TANK BEING FULL OF WATER

B BLACK
W WHITE
G GREEN

VIEW FROM BACK OF PANEL

REVERSE POLARITY INDICATOR

PILOT

CIRCUIT BREAKERS

PLUG HOLES FOR ADDITIONAL CIRCUITS

TERMINAL BLOCK

MAIN CIRCUIT BREAKERS

TOGGLE SWITCHES

TIE TO GROUND SYSTEM ENGINE

OUTLETS

WATER HEATER

SHORE POWER RECEPTICAL

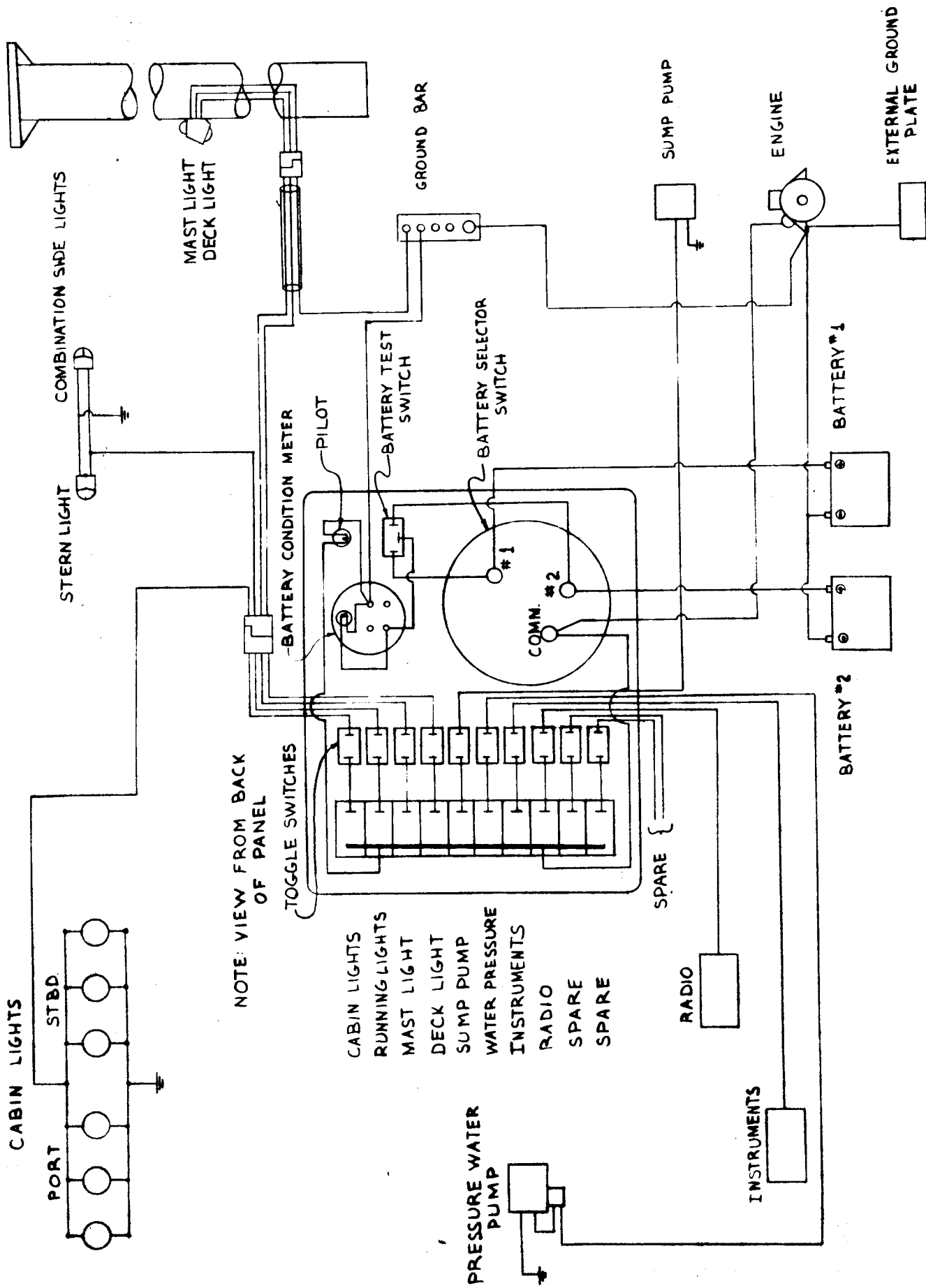

16.8 D.C. WIRING DIAGRAM

16.9 PLUMBING LAYOUT

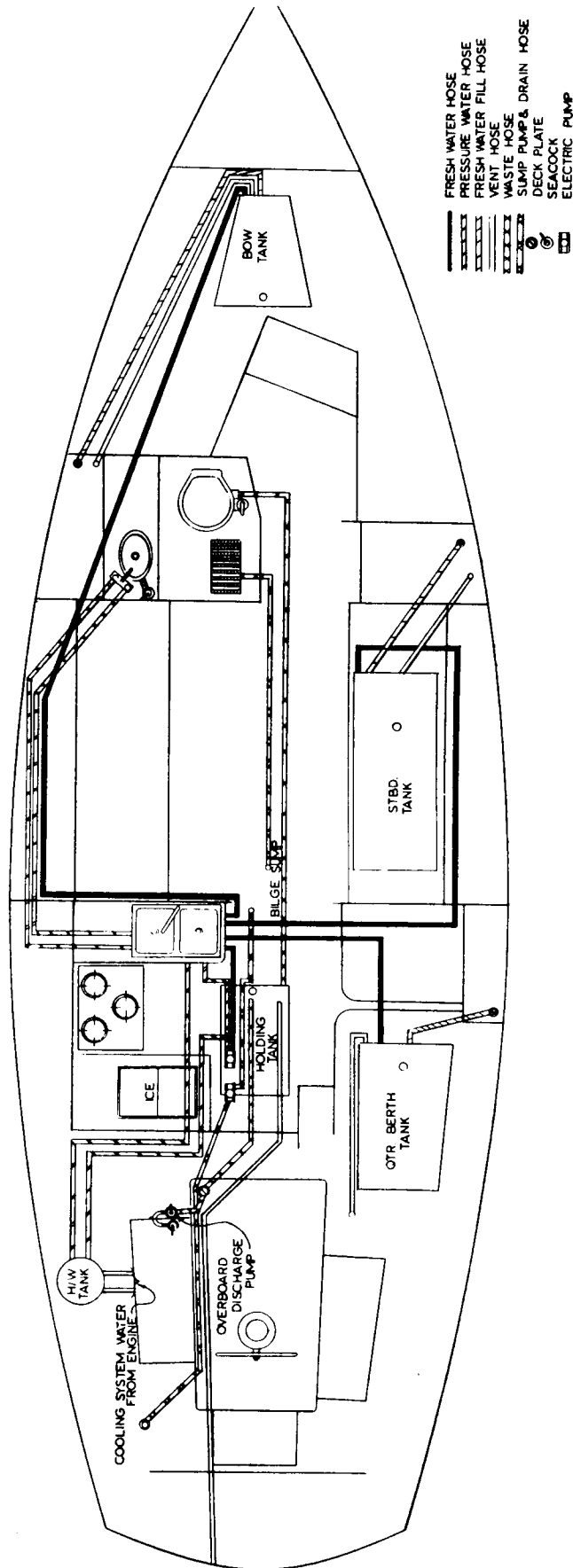

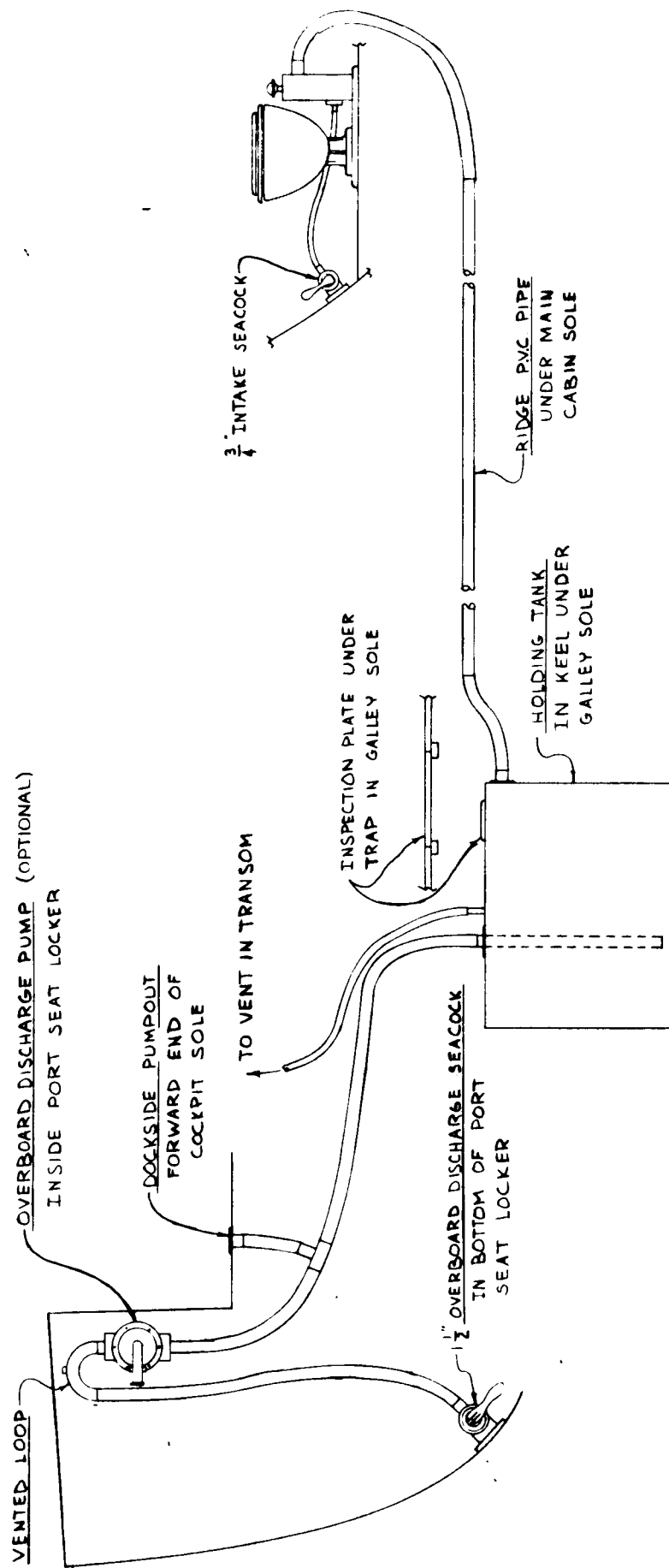

16.10 HEAD SYSTEM

16.11 PRESSURE WATER SYSTEM

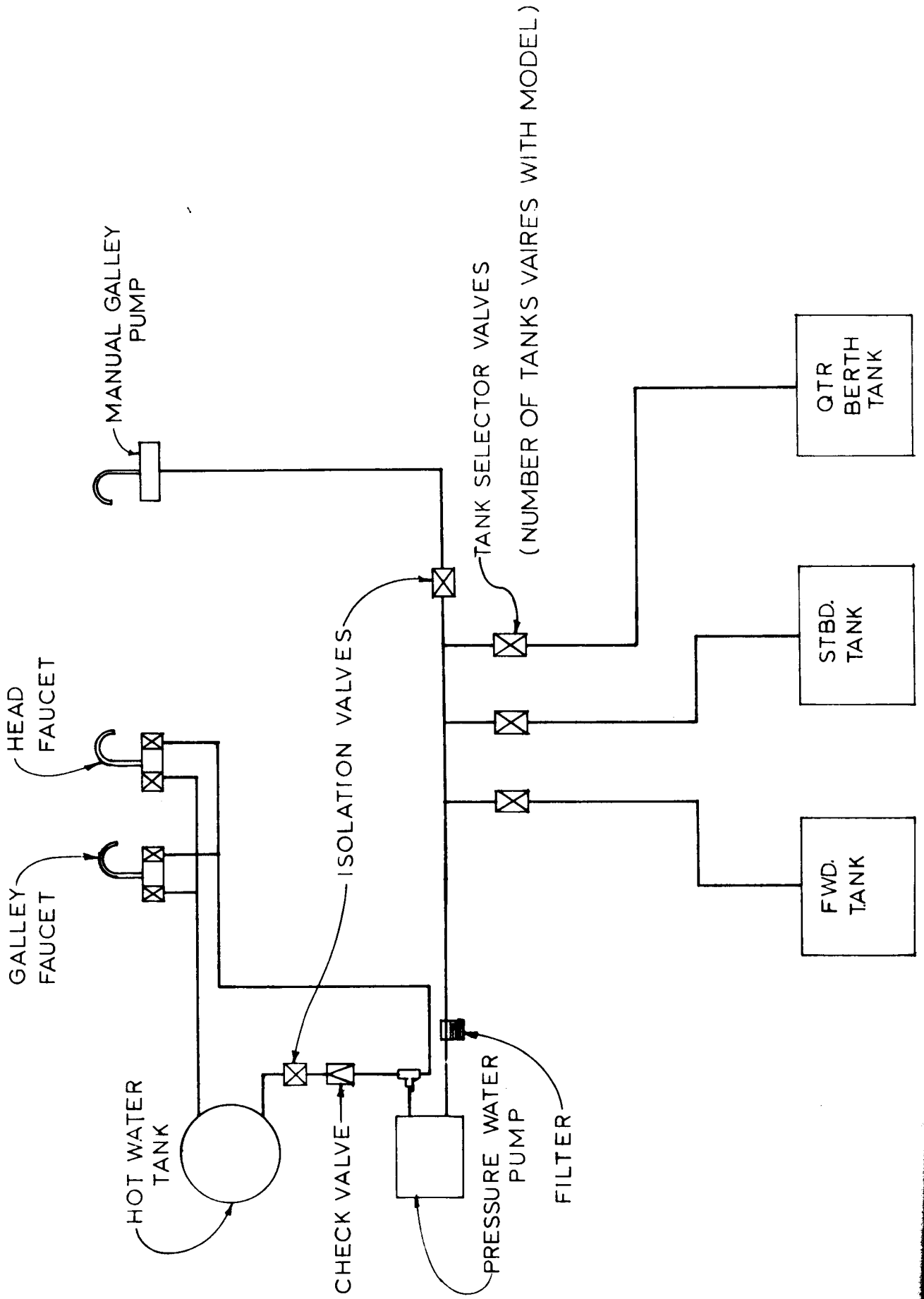

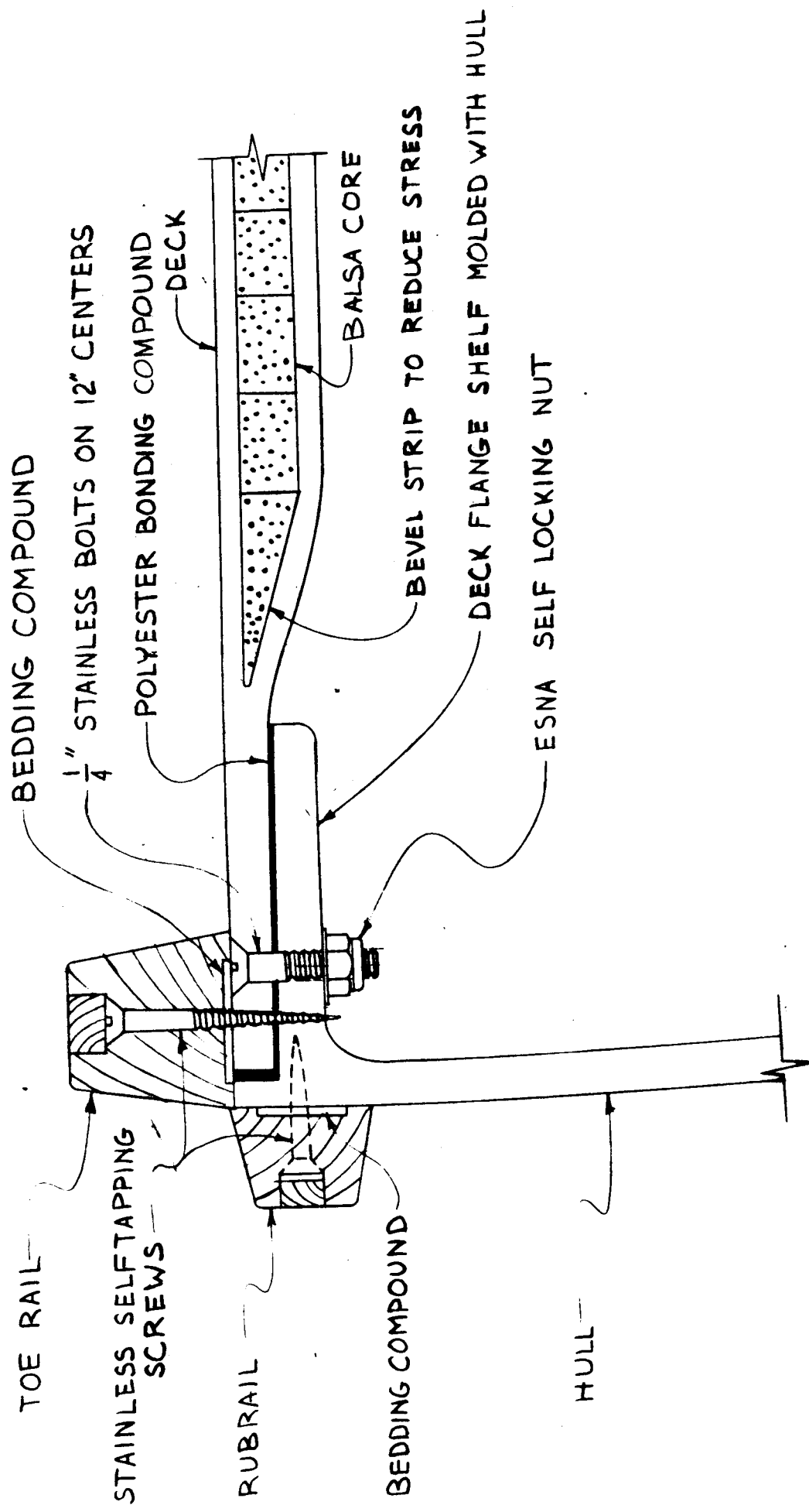

16.12 HULL/DECK JOINT

16.13 CHAINPLATE REINFORCEMENT

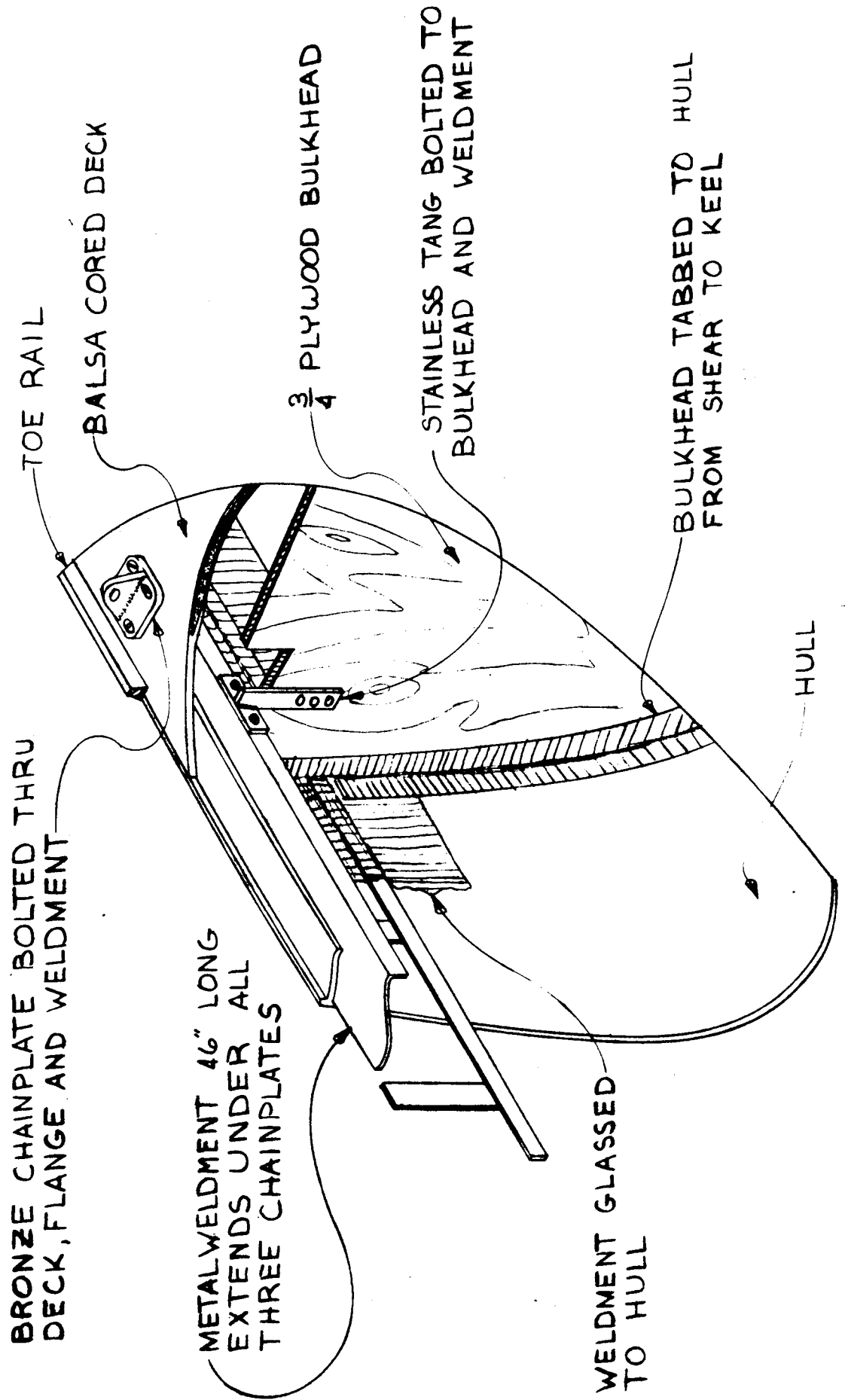

16.14 LIFTING STRAP PLACEMENT

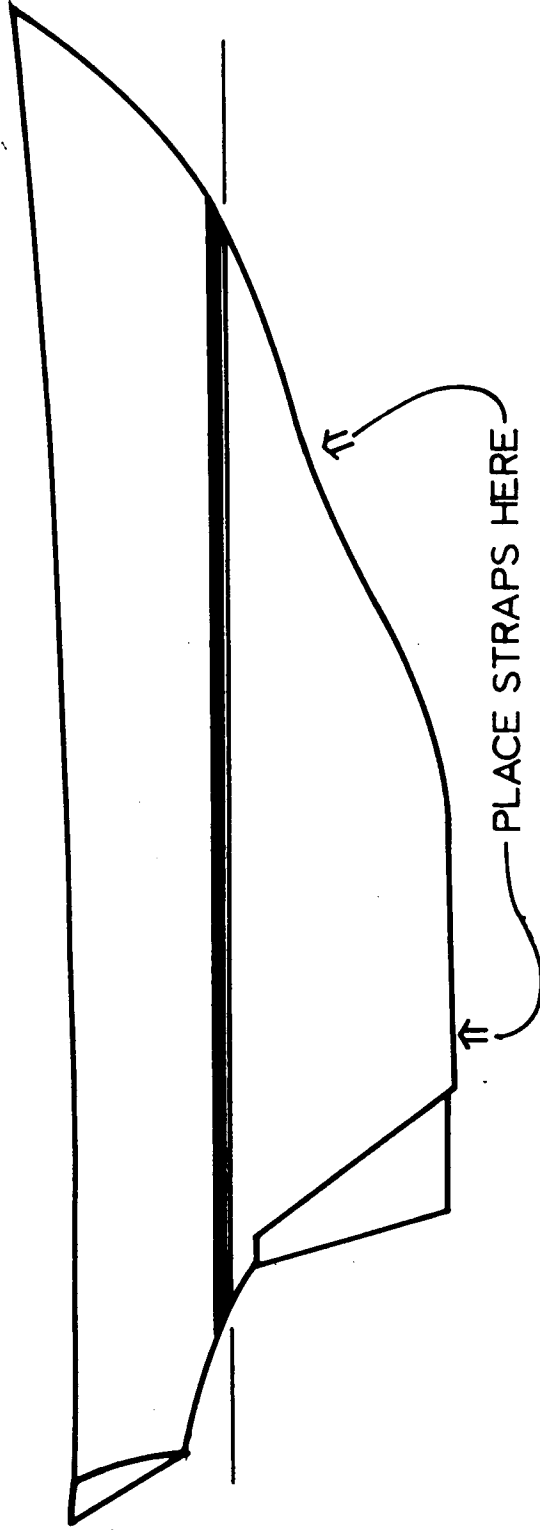

NOTE: BE CAREFUL NOT TO LOCATE
THE AFTER STRAP UNDER
THE RUDDER