

Rayson
Filter
use
2000 sm
filter
element

Farymann Diesel

INSTRUCTION MANUAL MARINE DIESEL ENGINES

Oil
about
15 g +
for oil
change

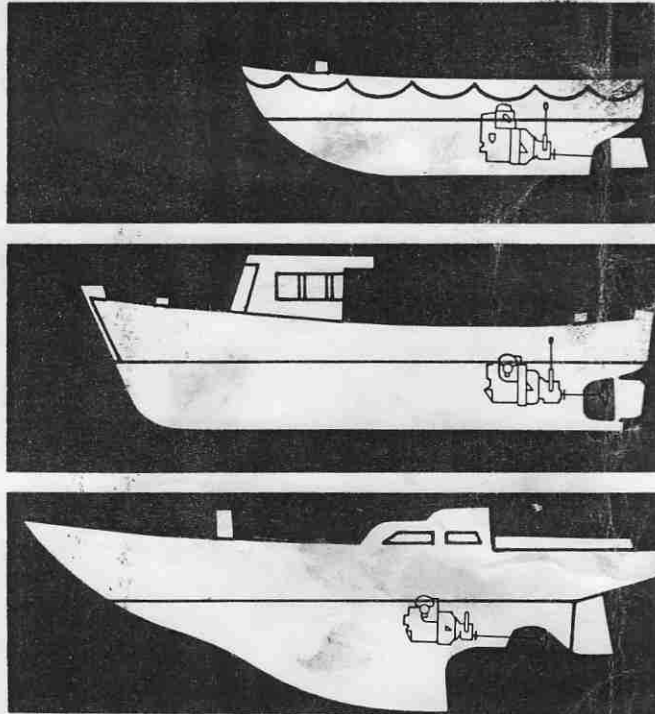

684 LAMPERTHEIM · WEST GERMAN
TEL. 062 06/20 01 · TELEX 46571

SMALL BELT
LARGE
K&H GERMANO CONTINENTAL 10 X 560
OATIBELT-SK SPZ 912 LW

BELTS

INSTALL LARGE BELT FIRST
KEEPING TWO BOLTS THAT HOLD BRACKET
SUPPORTING SMALL YELLOW WHEEL LOOSE
ENOUGH TO MOVE ARM. SLIDE OPEN END
WRENCH UP TO TIGHTEN BIDS WHILE KEEPING
SMALL BELT TIGHT

ADJUST TENSION ON LARGE BELT
BY LOOSENING ADJUSTER & PULLING
UP ALT. WHILE RETIGHTENING TWO BOLTS

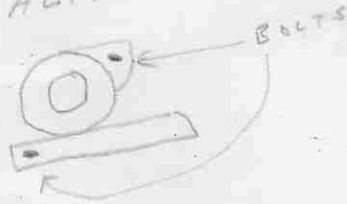

1. 76 CD

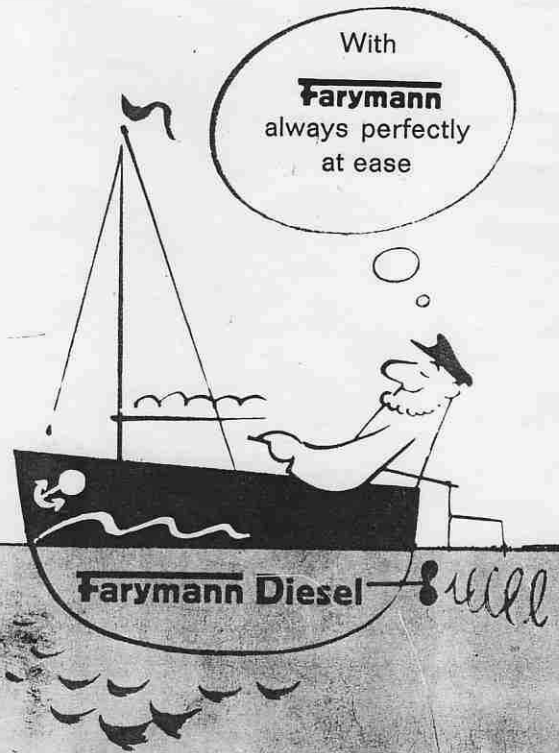

CONTENTS	Technical data	3
	Description of engines	4
	Description of gearbox	8
	Preparation for initial start-up	9
	Fuel and lub.-oil	10
	Daily checks	10
	Starting up the engine	11
	Hand starting	11
	Electric starting	12
	Stopping	12
	Frost hazard	13
	Care and maintenance	14
	Time schedule	14
	Engine	15
	Gearbox	19
	Storage of engine	20
	Electric system	21
	Restoring to service	21
	Trouble shooting	22
	Technical information sheets	
	Marking on oil dipstick	25
	Fuel system	27
	Cooling water circuit	28
	Electrical wiring diagrams	30

TECHNICAL DATA

ENGINE	K 30	L 30	A 30/A 40	R 30	P 30	S 30
Output HP (DIN/SAE)	5/6	8/9	10/12	20/24	22/26	26/32
Speed RPM	2500	2800	2500	2500	2500	2500
Torque (max) ft lb	11	16	21	38	46	54
No. of cyl.	1	1	1	2	2	2
Cubic capacity cm ³	298	4,2	582	1160	1270	1550
cu in	17	25	35	72	78	95
Valve clearance (Intake + Exh.) (cold)	0,1 - 0,2 mm (0,004")					
Decompression device - cold	1 mm (0,04") maximum stroke					
Engine oil						
Summer	HD SAE 30					
Winter	HD SAE 20					
Oil filter	PUROLATOR PC 27					
Fuel filter element	PUROLATOR PM 456					
BOSCH-Equipment	K 30	L 30	A 30/A 40	R 30	P 30/S 30	
Injection pump	0414.151.990	0414.151.990	0414.151.990	0414.162.984	0414.172.031	
Nozzle holder	0432.191.887	0432.191.887	0432.281.831	0432.281.831		
Nozzle	0433.171.003	0433.171.012	0433.271.184	0433.271.191		
Nozzle opening press.	200 kp/cm ²	200 kp/cm ²	175 kp/cm ²	(2490 p.s.i.)		
Reverse gear	K 30 Ronim	A 30 / A 40 Nanni B 6		R 30 / P 30 Hurth/Nanni HBW10/G12	S 30 Hurth/Nanni HBW10/F16	
Propeller rotation	right hand					
Electrical equipment	12 V					
Min. size battery	56 AH	56 AH	88 AH	88 AH	88 AH	
Tightening torques (all types)	ft lb		mkp			
Cyl. head nuts	43		6			
Rocker arm bracket	58		8			
Con.-rod bolt	43 (S 30 : 58)		6 (S 30 : 8)			
Main bearing plate	22		3			
Injection pump	18 - 22		2,5 - 3			
Delivery valve	25 - 29		3,5 - 4			
Press-line connector	14 - 22		2 - 3			
Nozzle into holder	29		4			
Nozzle holder	22		3			
Flywheel	impact wrench					

1 m/6000

DESCRIPTION OF ENGINES

✓
A 30 M / A 40 M
K 30 M

Single cylinder, four-cycle diesel engines. Direct injection sea-water cooled. Forged crankshaft with roller bearings in the connecting rod bearings and main bearings. Splash lubrication. Watercooled exhaust.

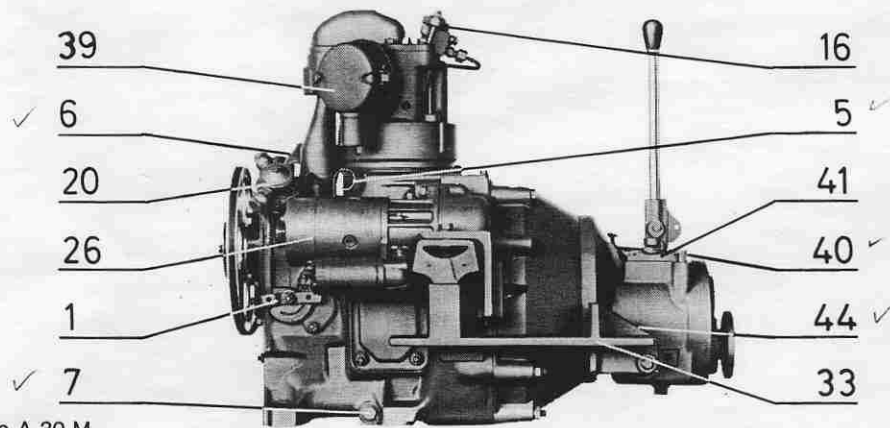

Engine A 30 M

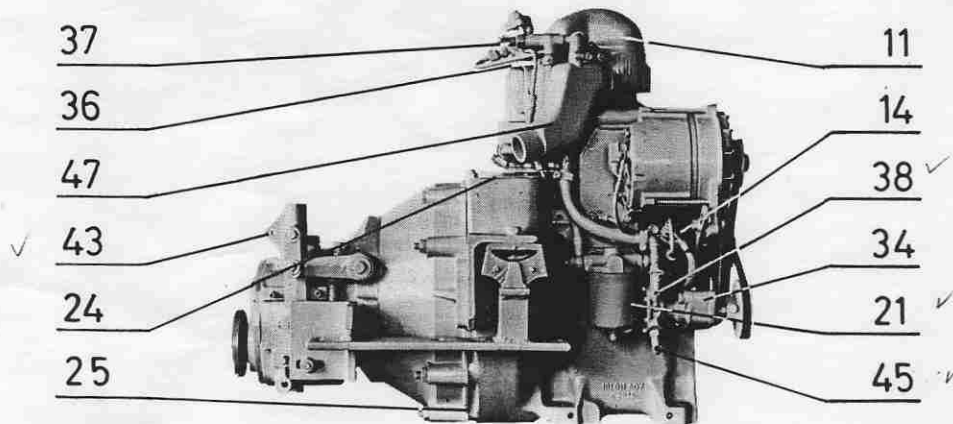

Engine A 30 M

Engine A 40 M

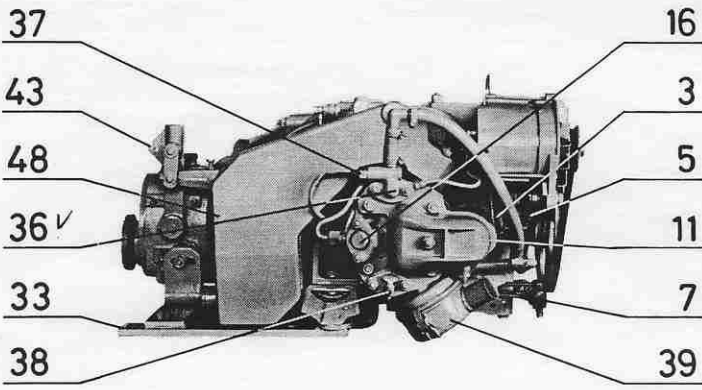

Engine K 30 M

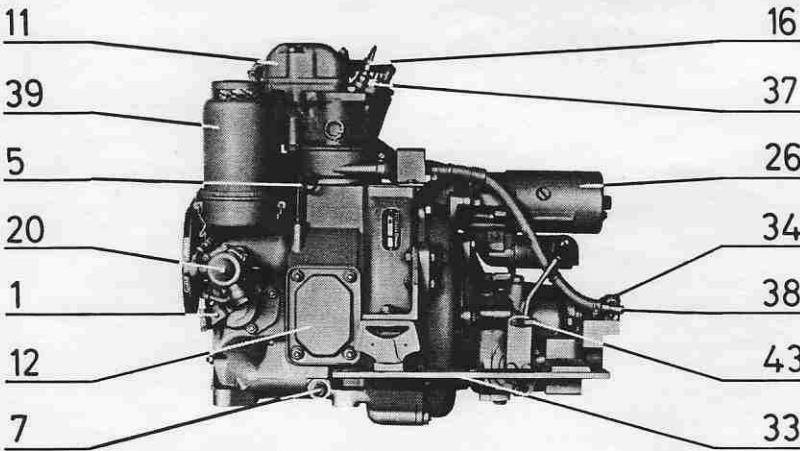

Impeller

SINGLE CYLINDER ENGINES

A 30 M vertical, A 40 M horizontal, L 30 M vertical, K 30 M vertical

- | | | |
|----------------------------------|--|--|
| 1- Throttle control + stop lever | 21- Fuel filter ✓ | 40- Oil dipstick (gearbox) ✓ |
| 3- Decompression device | 24- Mark for TDC (remove protective cover) | 41- Housing cover (gearbox) |
| 5- Oil dipstick | 25- Flywheel housing flange | 42- Gearshift lever |
| 6- Lub.-oil filler | 26- Electric starter motor | 43- Connector for remote control ✓ |
| 7- Lub.-oil drain plug | 33- Marine mounts | 44- Lubrication nipple (clutch thrust bearing) ✓ |
| 9- Breather (crankcase) | 34- Water pump | 45- Water inlet ✓ |
| 11- Rocker arm cover | 36- Thermostat | 47- Watercooled exhaust elbow |
| 12- Crankcase cover | 37- Connector for Thermometer | 48- Exhaust muffler with water injection |
| 14- Injection pump | 38- Water drain ✓ | |
| 16- Nozzle holder | 39- Air intake silencer | |
| 17- Fuel return line | | |
| 20- Fuel feed pump | | |

arymann Diesel

R 30 M/P 30 M
S 30 M

V-2, four-cycle diesel engines. Direct injection seawater cooled.
Cast steel crankshaft. Roller bearings on flywheel side. Pressure
lubrication. Watercooled exhaust.

As above engines are almost identical with regard to design and appearance, model
S 30 M is illustrated only.

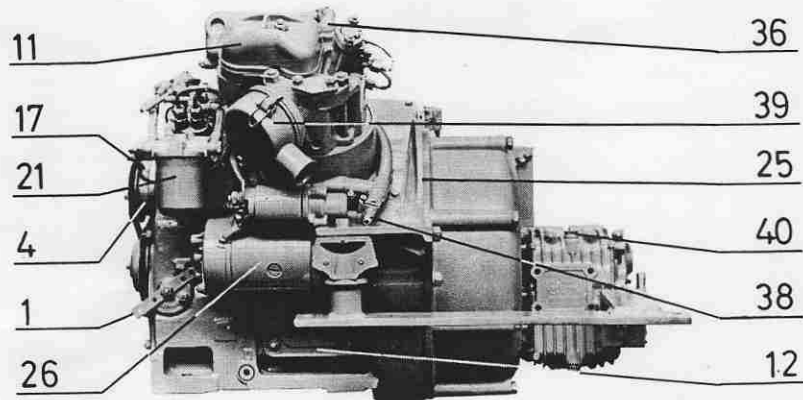
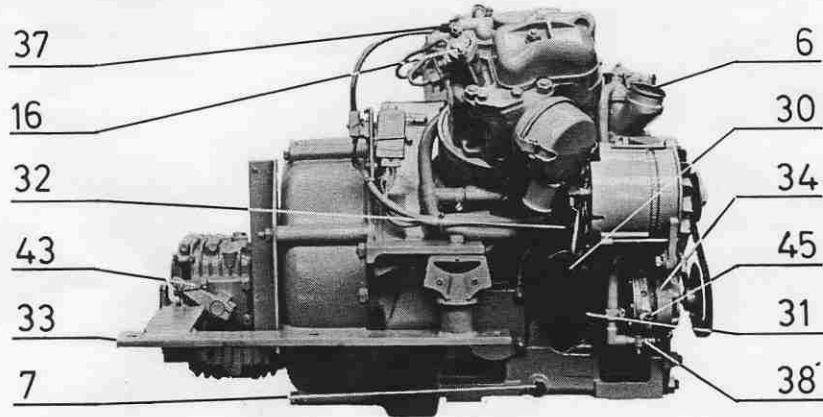

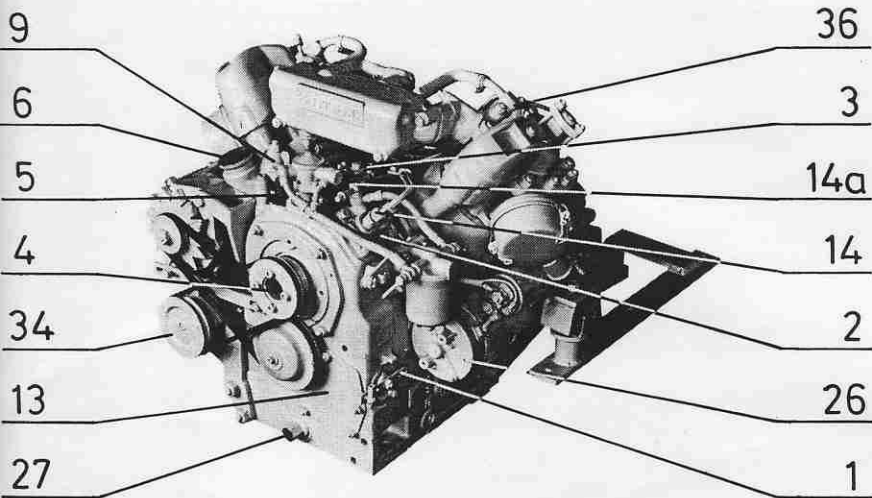

1m/6200

V-2 ENGINES

R 30 M / P 30 M / S 30 M

- | | |
|-------------------------------|---|
| 1- Speed control + stop lever | 27- Oil strainer |
| 2- Excess starting fuel | 28- Crankcase cover |
| 3- Decompression device | 29- Inspection cover |
| 4- Camshaft | 30- Lub.-oil filter |
| 5- Oil dipstick | 31- Oil cooler |
| 6- Lub.-oil filler | 32- Oil pressure switch |
| 7- Lub.-oil drain plug | 33- Marine mounts |
| 9- Breather (crankcase) | 34- Water pump |
| 11- Rocker arm cover | 36- Thermostat |
| 12- Crankcase cover | 37- Connector for Thermometer |
| 13- Governor inspection cover | 38- Water drain |
| 14- Injection pump | 39- Air intake silencer |
| 14a- Vent screw | 40- Oil dipstick (gearbox) |
| 15- Fuel pressure line | 41- Housing cover (gearbox) |
| 16- Nozzle holder | 42- Gearshift lever |
| 17- Fuel return line | 43- Connector for remote control |
| 20- Fuel feed pump | 44- Lubrication nipple
(clutch thrust bearing) |
| 21- Fuel filter | 45- Water inlet |
| 25- Flywheel housing flange | 46- Water outlet |
| 26- Electric starter motor | |

MARINE REVERSE REDUCTION GEARBOX ✓

Engine Type	K 30 M	L 30 M	A 30 M	A 40 M	R 30 M	P 30 M	S 30 M
Manufacturer	Ronim		Nanni		Hurth Nanni		
Type	FG 3 Ro		FG 3 B 6 ✓		HBW 10 G 12/F 16		

1) RONIM Gearbox

Gearbox is fitted with 2 cone clutches and respective servo-engaging mechanism. The water circulating pump is directly flanged to the gearbox. Oil check through insert-type dipstick.

2) ✓ NANNI Gearbox

Power transmitted through single disc friction clutch. Adjustment see page 20.

✓ Oil check through insert-type dipstick. ✓

Serial number and type are punched into gearbox housing. Please state these numbers whenever parts are needed.

Example:

5758 B 6 / V 2

B 6 = type of gearbox

V = size and form of engine
adapter flange

2 = reduction ratio
(2 : 1)

5758 = serial number

Other marking mean special
execution.

✓ Care should be taken that gears are only shifted at low engine speed. ✓

3) HURTH Gearbox

Hurth marine gearboxes are helical gear transmissions shifted via 2 internal mechanical friction clutches. It is designed to permit reversing operations at full engine speed in case of emergency. As clutches are exactly set to rate nominal torque, shock loads from propeller on shaft will not be transmitted to gearbox or engine.

Oil check through threaded dipstick. When checking oil, just insert dipstick – do not thread in. After check thread in and retighten.

Example

HBW 10-2 R

94740

05-2893

HBW 10

94793 = Type of gearbox

2 R = Reduction ratio 2 : 1

05-2893 = Serial number

1. PREPARATION FOR INITIAL START-UP

- 1.1. ✓ Check bolt and hose connections and all pipeworks for leaks and tighten nuts and bolts if necessary. This applies especially to the mounting bolts and the retaining bolts on the exhaust and shaft assembly.
- 1.2. ✓ Mark oil dipstick of engine according to the inclination of the engine in the fully loaded boat (see page 25).
- 1.3. ✓ Fill tank with fuel.

Engine and gears are not filled with oil by suppliers. Make sure that both oil drain plugs are tight.

Important: absolute cleanliness is essential when filling. The area around the filler should be cleaned before opening it. Use only clean containers, funnels or strainers.

a) **LUBRICATING OIL:**

Use only well-known HD brands of engine oil, and keep to the brand selected, if at all possible. Never mix different brands when topping up the oil.

	Summer	Winter
Engine	HD SAE 20 ✓	HD SAE 10
Gearbox	HD SAE 30 ✓	HD SAE 30

The engine oil can also be used for lubricating the gearbox but not vice versa. Hurth gearbox uses automatic transmission fluid type A or branded HD engine oil.

Warning: Additives such as molybdenum sulphite or the like must not be contained in the oil under any circumstances.

Attention:

When engine installed under inclination correct sump capacity and dipstick as described on page 25.

Caution: use only HD oils for the engine. An SAE 20/30 multigrade oil can be used for all-year-round operation.

REVERSE GEAR OIL CAPACITY

Type Engine	GEARBOX			
	Ronim Nanni	FG 3 Hurth	Ronim Nanni	FG 3 Hurth
	ltr.		US pints	
K 30 M	0,3		0,63	
L 30 M				
A 30 M ✓	0,6	0,6	1,27	1,26
A 40 M	0,6		1,27	
R 30 M	0,6	0,5	1,27	1,05
P 30 M	0,6	0,5	1,27	1,05
S 30 M	1,0	0,5	2,10	1,05

b) FUEL:

Obtain fuel only from filling stations equipped with a pump and built-in filtering system, otherwise filter the fuel yourself with a fine strainer (if necessary using a nylon stocking). Always replace the filler cap immediately.

Use clean commercial grade branded diesel fuel according to

DIN 51601 (German Standards), equivalent to
B.S. 2869: 1957 Class A (British Standards) or
→ A.S. No. 2 (American Standards).

The sulphur content must not exceed 0,5% (weight). A lower value is specially important for sea water-cooled engines operating at relatively low temperatures. Never use gasoline diesel fuel mixture or any weight fuel oil.

✓ **Caution:** Bleed the fuel system after the first filling. Never allow the tank to drain completely.

1.4. RUNNING-IN

A new or reconditioned engine must be carefully run-in. During the first 20 hours, only use full engine power for very short periods. After first 20 hours engine power can gradually be increased. A first oil change is necessary after 20 hours. ✓ Check cylinder head bolts at the same time. Retighten, when engine is cold. Tightening torques see technical data sheet.

2. DAILY CHECKS BEFORE STARTING

2.1. Check oil level in engine and reverse gearbox. If necessary fill to the top mark of the dipstick.

The chromium-plated piston rings may cause a slightly higher lub.-oil consumption during the running-in period (80-100 hours).

2.2. Screw in the lubricating cup (if provided) on the cooling water pump by half a turn. Check tight fit of locknut on stuffing box.

2.3. Check the diesel oil supply in the tank and open the tank cock. If the engine has not been in operation for some time, the fuel system should be bled in accordance with the operating instructions.

2.4. After checking the drain cocks and the sea water filter, open the sea cock completely and check flow of sea water through transparent cover of sea water filter.

3. STARTING UP THE ENGINE

- 3.1. Move gear lever to neutral position (mid-position vertical).
- 3.2. Move the engine speed control lever to the full power position (max.) (A) (Fig. 1)

With Farymann Unicontrol (single lever) pull hub assembly outwards till the locking pin is clear of slot, thus gear shifting is disengaged and lever can be turned into max. speed position. (With Morse single lever control pull knob.)

Morse type single lever gearshift: pull out knob.

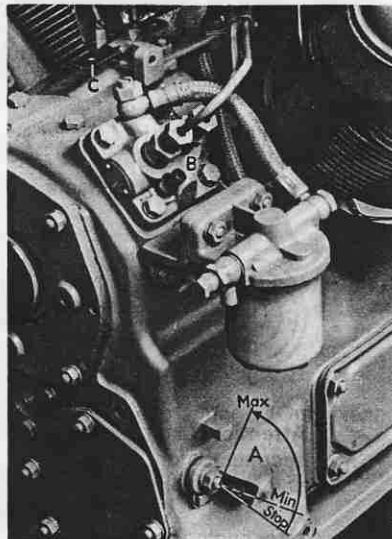

Fig. 1

- 3.2.1. **HAND STARTING**
Operate lever or pushbutton (B) for starting fuel (Fig. 1)

Operate the decompression lever (C) with your right hand and slowly turn the starting crank in the camshaft anticlockwise with your left hand. Listen for characteristic creaking of the injection nozzles.

Turn the crank with your left hand as fast as possible. When the maximum impetus is reached release the decompression lever and carry on turning in order to overcome the initial compression resistance. Rapid turning, not force, is what matters!

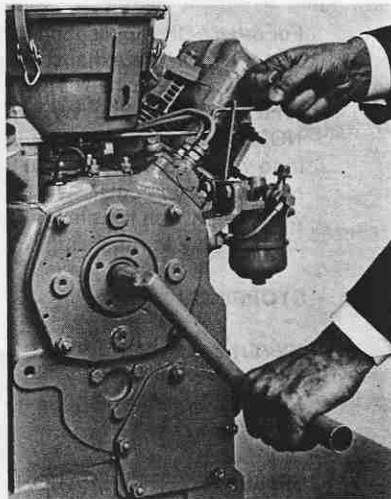
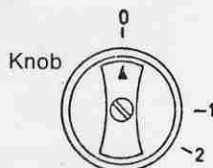
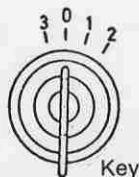

Fig. 2

When hand-starting engine with electric start - turn ignition key to first notch. X ✓

3.2.2. ELECTRIC STARTING

- 1) Switch on electric system: turn key or knob of starter switch into position (1). Then pilot lamps for battery charging and oil pressure (2-cyl. only) must light up.
- 2) Turn key or knob of starter switch to extreme position (2) and hold it there until first firing stroke. Then IMMEDIATELY RELEASE key or knob of starter switch and make sure that same returns into position (1).



0 = off
 1 = on
 2 = start
 3 = spare position

Attention: Limit each starting trial to 10 seconds maximum and wait for 30-60 seconds before repeating (to save battery). Operate starter only after engine came to a complete stop.

After engine has started and control lamps are out, run engine at medium speed under light load for warm up.

3.2.3. CHECKING AFTER STARTING

For most of the applications, the entire cooling water is injected into the exhaust to cool down the exhaust gases (i.e. reduce the noise level), and to be able to dispose of the exhaust gases by means of rubber hoses. CHECK WHETHER A FINE SPRINKLE OF WATER COMES OUT OF THE EXHAUST AND WHETHER NOISE OF EXHAUST IS NORMAL.

If no water comes out, then the exhaust produces a considerable noise which means that no cooling water is being injected into the exhaust and that cooling water supply on the engine is not in order. In this case engine has to be stopped immediately for checking.

3.3. STOPPING**3.3.1. NEVER STOP THE ENGINE BY OPERATING THE DECOMPRESSION LEVER!**

3.3.2. Never completely stop the engine while it is running at speed, but let it idle for a short time.

SINGLE LEVER OPERATION

Farymann Unicontrol - put lever into neutral/idling position and tilt hub pulling lever outwards. Hold until engine comes to complete stop. (With Morse: pull additional stop cable and hold until engine comes to complete stop.)

TWIN LEVER OPERATION

Move the speed control lever beyond the idling position and hold it there until the engine stops.

In either case return the speed control lever to full load position as soon as the engine has stopped.

ELECTRICAL SYSTEM

After stopping the engine as described above, turn the key to the 0-position and remove it or respectively switch off ignition.

Close the SEA COCK (do not forget to re-open before next engine start-up).

- 3.3.3. After engine halt always engage gear to relieve clutch springs. (Only Nanni gearbox.)

Fill fuel tank **after** completing a run. Partially filled tank will collect moisture if engine is not operated for any length of time.

- 3.3.4. **FROST HAZARD**

Open all drain cocks and ensure complete drainage. Push a wire through the cocks to ensure unimpeded flow. Finally crank the engine by hand until the cooling water pump is empty, too.

In case of V-twin engines, drain the water-cooled exhaust manifold.

In exceptional cases, where lines or water chambers are located below the drain cocks, the appropriate pipe or hose connections must be opened in order to drain them.

Remove intake line with sea water filter from the cock!

If cooling water is injected into the engine exhaust pipe, the water lift silencer must be drained.

- 3.3.5. **BATTERY**

When charged, the battery can safely withstand temperatures as low as -15°C ($+ 5^{\circ}\text{F}$). At lower temperatures it should be removed and stored in a frostproof place.

ATTENTION:

Engines equipped with A.C. generators may **not be run with battery disconnected** (destruction of diodes of voltage regulator). Even extremely short trial runs only with battery properly connected.

4. CARE AND MAINTENANCE

The operations listed in the following schedule must be repeated until the engine is due for overhaul.

4.1. OPERATION

ENGINE	hours of operation				
	Daily	60	120	250	500
✓ Check oil level	●				
✓ Change lub.-oil			●		
✓ Replace spin-on oil filter				●	
Clean oil strainer				●	
Flush out crankcase					●
✓ Examine nuts and bolts for tightness				●	
Check valve clearance			●		
✓ Check sea water filter	●				
Lubricate water pump (applies only to JABSCO 1/4" pump)	●				
✓ Check V-belt tension	●				
✓ Check water pump impeller			●		
Examine and clean thermostat				●	
✓ Check all pipelines for leaks		●			
✓ Check fuel filters					●
Drain (clean) fuel tank			●		
GEARBOX					
✓ Lubricate clutch bearing (Nanni)		●			
✓ Check clutch clearance (Nanni)			●		
✓ Change lub.-oil				●	
✓ Lubricate remote control mechanism				●	
ELECTRICAL SYSTEM					
Maintain electrolyte level in battery	●				
Check specific gravity of battery			●		
Check all cables and connections			●		
Grease starter rim-gear on flywheel					●

4.2. CHANGING THE ENGINE OIL

Change the oil only with the engine at operating temperature (scavenging effect) in a new engine after appr. 20 h. Change the oil again after approx. 50-60 hours. Later on every 120 hours.

A separate hand-drain pump with hose and cock is supplied with the FARYMANN MARINE ENGINE. If this cock has not been fitted to the engine during installation it can be fitted to replace the oil drain plug. The hose supplied connects cock with drain pump. Remember to close the cock after draining the oil.

Engine oil must be changed whenever engine is to be put out of service for extended periods.

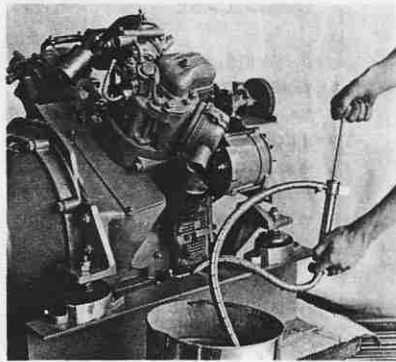

Fig. 3

4.3. OIL FILTER

(applies only to V-2 engines)

The spin-on oil filter (1) cannot be cleaned and must be replaced.

Lightly oil the rubber seal, tighten it and top up oil level.

A suitable special spanner (2) is supplied within the tool kit.

Check for leaks with the engine running!

Filter: PUROLATOR

Type: PC 27 (Standard)

PMP 31/2 (Oversize)

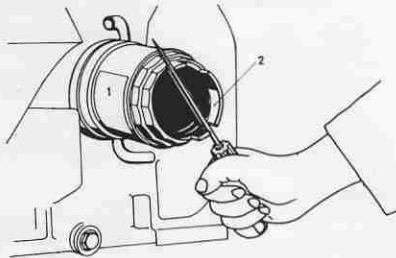

Fig. 4

4.4. CRANKCASE

If during a normal oil change or when cleaning the oil strainer the oil is seen to contain a lot of sludge, the crankcase should be washed out sooner than recommended in the schedule. Flush with diesel oil after removing the crankcase cover.

Absolute cleanliness is essential!

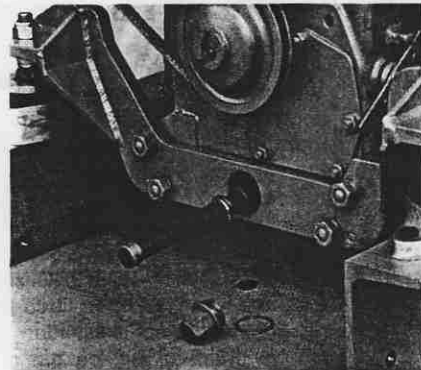

Fig. 5

4.5. CRANKCASE BREATHER

Crankcase breather (combined with oil filler) should work audibly. Check with the engine running at low speed. The thin steel valve must always be kept clean. It must lie flush on its seat, otherwise it should be replaced. If necessary, take off complete breather housing and wash out thoroughly with gasoline or diesel fuel.

If there are any oil leaks on the engine check this breather valve first.

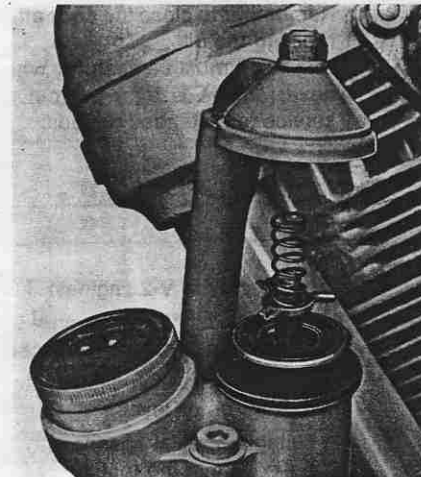

Fig. 6

4.6. VALVE CLEARANCE

Adjustment on cold engine with both valves closed (TDC of firing stroke). Clearance 0,1-0,2 mm (0,004"). With new engine, valve clearance has to be checked after 20 first operating hours.

Important: after major repairs the cylinder head and rocker arm support must be firmly bolted in position with nuts to final torque tightened before valve clearance is adjusted.

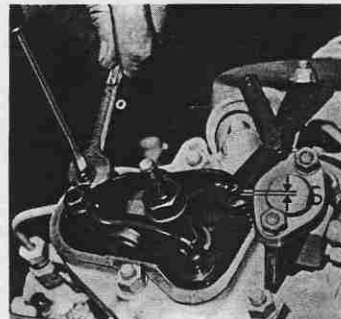

Fig. 7

(4 BOLTS)

4.7. V-BELT TENSION

Too tight a belt is destructive to bearings of the driven parts. Adjust for $\frac{3}{8}$ " slack from a straight line over outer diameter of drive and driven pulleys, midway between pulleys.

4.8. WATER PUMP IMPELLER

The neoprene impeller has a relatively short life and must therefore be inspected regularly. If the water pump is allowed to run dry for more than a few seconds (sea cock closed) the impeller may be completely ruined. Remove cover of pump and release the impeller (C) from the shaft by applying 2 screwdrivers (E) under the hub of the impeller. Remove all traces of rubber and smooth any damaged surfaces. Fit a new impeller. A spare impeller should always be kept on board.

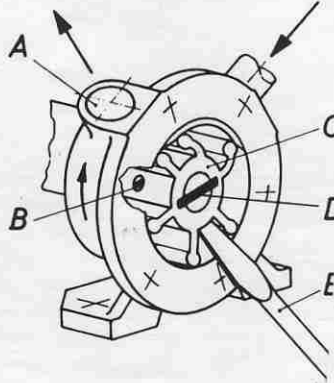

If impeller is held by lock screw, loosen same with screw driver thru opening (A) or remove complete shaft-impeller assembly after removing V-belt pulley.

STUFFING BOX (JABSCO Pump with plain bearing): Tighten by hand then lock with locknut. To lubricate plain bearing, small water leak is permitted.

4.9. THERMOSTAT

Farymann Diesel engines are cooled directly by sea water. The raw water never touches the engine block, but circulates only around the replaceable cylinder liner, head and exhaust system. Cooling water jacket around cylinder is constructed of a non-corrosive, glass-fibre-reinforced-plastic. Outer wall of cylinder is zinc-plated.

In addition, the Farymann diesel has been built to operate at cooling water temperatures below that at which salts and minerals precipitate in sea water.

No separate fresh water cooling system is needed or recommended.

A thermostat with a setting of 55° C (120° F) is fitted to the engine. Any deposits that appear on the thermostat can be removed with dilute hydrochloric acid. Flush afterwards with fresh water.

Caution: during assembly make sure that the small hole (equipped with a tiny cotter pin) in the fitting plate of the thermostat, which permits water to penetrate even in the closed position, is not obstructed.

Remove Fuel Filter

To Get To Fuel Filter
Remove Large
Remove Belt

1) Take off nut (built in washer) under canister

2) Undo canister by twisting tighter 1st to break seal, then counter clockwise. Although canister has no threads, just does go through rubber washer in bottom of canister which seems to be threaded. Pull down as you turn.

3) Filter held up w/ nut & washer. Remove nut & washer + twist of filter.

Install

- 1) Check gasket on top of canister
- 2) Slide in new filter
- 3) Install washer then nut
- 4) Tighten canister
- 5) Install nut washer comb.
- 6) Loosen nut on pump
- 7) Pump in injector till fuel comes out nut
- 8) TIGHTEN

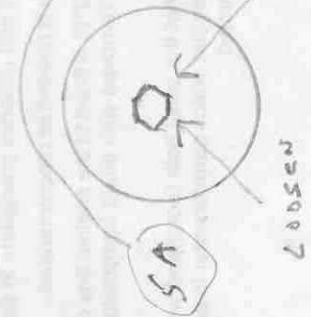

TO GET TO IMPELLOR
+ FUEL FILTER YOU NEED TO
REMOVE LARGE FLY WHEEL (4 BOLTS)
REMOVE BELTS

Shaft
from
thru

Remove

UVT

15 THEN
OUT

Raycox
10 Fuel Filter
Comes w/
2 gaskets
Filter element
2000 SM
FOR
Filter

WAPA
WICK
3261
5749

4.10. SEA WATER FILTER

If a sea water filter is installed in the water pump intake line, the cover should be transparent in order to permit observation of the flow of the cooling water and any contamination of the filter.

Attention: After cleaning of filter it has to be checked that the cover is refitted carefully preventing any air to be aspirated by the water pump.

4.11. FUEL FILTER

The life of the fuel filter depends entirely on the degree of purity of the fuel used. A loss of engine power may be due to a shortage of fuel brought about by a clogged filter. If this is suspected the air vent screw in the fuel pump should be opened. Unsteady flow, even after pumping, indicates a contaminated filter. Change the filter element (see fig. 8). We recommend a PUROLATOR PM 456 filter element.

A water contaminated fuel system causes fuel filter paper element to become waterlogged which results in fuel starvation (loss of power).

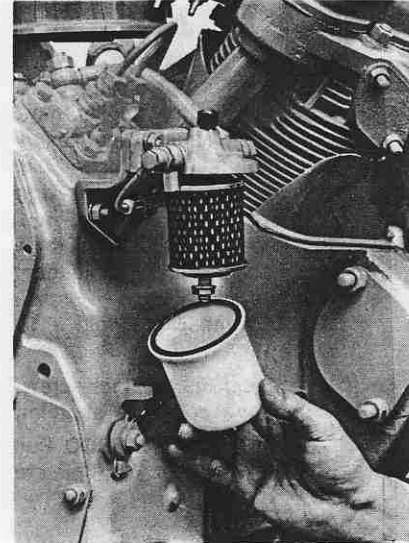

Fig. 8

4.12. BLEEDING

Although all FARYMANN marine engines are equipped with the automatic bleeding system (see page 29) (which requires of course that boat yard has installed a fuel return line to the fuel reservoir) it can occur that fuel system has to be bled. Don't loosen banjo bolts or other connectors of fuel lines but only vent screw on injection pump (see Fig. 8/D). Turn engine by crank or starter motor until absolutely bubble-free fuel leaks. Retighten vent screw thoroughly.

4.13. **CLUTCH BEARING (NANNI)**

Do not grease excessively, otherwise surplus grease will contaminate the clutch lining.

4.14. **CLUTCH CLEARANCE (NANNI-Gearbox)**

To set the clutch bearing clearance correctly, proceed as follows:

Method:

- 1) Move the gear lever to the idling position (midposition). Release the locknut and unscrew the setscrew (67) until the threaded end of the screw is withdrawn into its tapped hole in the link (30).
- 2) Now tighten the screw (67) again, turning it clockwise by hand until it touches the clutch lever (31) and a definite resistance can be felt.

Note: clutch lever (31) is almost hidden behind link (30).

- 3) The gear lever should now be set at forward or reverse. The setscrew (67) is tightened further by a 2½ turns in a clockwise direction and locked with the locknut (87).

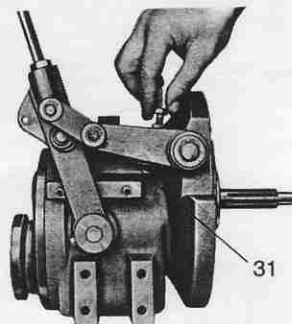
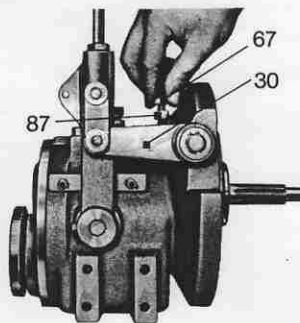

Correct adjustment ensures proper clearance between the clutch bearing and the clutch levers. Too much clearance means little clutch disengagement, which in consequence does not allow the dog clutch to engage entirely. Risks of damage.

4.15. **CHANGING THE GEAR OIL**

With new gearbox oil has to be changed after max. 100 hours.

If a line for connecting a hand pump is not provided, the gearbox top cover must be opened and the oil removed by means of a hand drain pump.

4.16. **GREASING THE STARTER RIM GEAR**

The starter pinion should mesh well over the entire length of the teeth. Remove the starter. Lightly grease the rim gear with the aid of a brush. Use e.g. BOSCH FT 1 V 31 grease.

4.17. **BATTERY**

Add only clean distilled water. Protect terminals with a light vaseline coating.

5. STORAGE OF ENGINE

Read this entire section before proceeding with lay-up!

If the engine is to be taken out of service for a lengthy period, e.g. during the winter, protect engine as outlined below:

Frost protection has already been dealt with in Para. 3.3.4.

The diesel engine must be protected from rust, irrespective of whether the boat is laid up on land or the engine removed. Rust e.g. in the fuel injection system can cause engine failure even where its presence cannot be detected with the naked eye.

5.1. LUB.-OIL AND FUEL SYSTEM

- 1) Clean the outside of the engine with diesel fuel or white spirit.
- 2) Drain off the engine oil while it is still warm and fill with anticorrosive engine oil, e.g. SHELL ENSIS 20 or ESSO RUST BAN up to the lower dipstick mark (MIN.).
- 3) Drain the fuel tank and clean it thoroughly. Drain the fuel filter. Then fill the fuel tank with several litres of a mixture of diesel fuel and SHELL ENSIS or RUST BAN at a ratio of 2 : 1. Bleed the fuel system.
- 4) Allow the engine to run for approx. 15 minutes so that all the pipelines, filters, pump and nozzles are filled with the protective fluid and the anti-corrosive engine oil mixture is evenly distributed inside the engine.
- 5) Remove the rocker arm cover and spray a mixture of diesel fuel and 10% SHELL ENSIS 20 on rocker arms, fit covers again.
- 6) With the speed lever at full power and the decompression lever actuated, so that engine will not fire, crank the engine several times so that the cylinder is well sprayed with the diesel fuel anti-corrosive mixture. Drain anti-corrosive oil from sump.
- 7) Remove the exhaust piping from the cylinder head or the exhaust manifold and cover the exhaust ports by means of adhesive tape. This also applies to the port of the air intake.

5.2. COOLING WATER SECTION

Drain all cooling water proceeding as described in para. 3.3.4. Remove water suction pipe from sea cock and remove waterline, injecting cooling water into exhaust elbow. Take a can with an emulsifying cooling water protection oil e.g. SHELL DONAX C or equivalent, and insert water suction pipe as well as a piece of rubber pipe fitted to water outlet (which normally injects into exhaust elbow) into can. Let engine run with this "closed circuit" containing the protection oil for the same time as mentioned in para. 5.1.4. Drain off oil and plug or refit both pipes to their proper positions.

Clean outside of engine and coat engine, metal parts of maneuvering controls and cable connections with anti-rust oil.

5.3. ELECTRICAL SYSTEM

Remove and store the battery in accordance with battery manufacturer's instructions. Take it to a station for maintenance.

As a last step, it is advisable to affix sign on the engine indicating that the engine has been inhibited.

6. RESTORING TO SERVICE

Although this subject has been dealt with in detail in Para. 1, we shall once again list the most important points.

- 6.1. Fill the fuel tank, test for unimpeded flow with the fuel filter installed and if necessary change the filter cartridge. Fill crankcase with specified HD lub.-oil, take battery on board and connect. Coat terminals with vaseline after tightening.
- 6.2. Take out fuel injection nozzle, clean and if possible have them immediately tested by your local BOSCH service-station, for correct injection pressure. With injector out turn the engine starter in order to remove anti-rust oil from cylinder. Re-fit injection nozzle.
- 6.3. Bleed fuel system, and connect all fuel-, water- and exhaust lines etc. Remember to remove the **plugs**. Check all water and fuel lines for leaks.
- 6.4. Start engine and make trial run, checking immediately whether the cooling water is flowing through the sea water filter to the engine. Re-check all lines, seals and hose connections for leaks.

7. TROUBLE SHOOTING

7.1. Faults are usually due to inadequate maintenance. In the event of a fault, first check whether all the points in these operating instructions have been followed.

If you cannot detect and remedy the fault even with the aid of the following table, it is essential that you apply to the nearest FARYMANN dealer or approved service station.

In order to ensure good service, always state engine type and serial number, e.g. 26 A 30 1025.

7.2. FAULT	POSSIBLE CAUSE	REMEDY
Engine does not start	Control lever at STOP	When starting always place at MAX. and if necessary operate excess starting fuel
	Fuel tank empty	Top up tank and bleed fuel lines
	Fuel filter clogged or waterlogged	Replace filter element
	Air in fuel system	Bleed
	Starter does not turn freely	Charge battery, examine terminals and tighten. (Emergency: use decompression device)
	Engine oil too viscous, espec. at low ambient temperatures	Use HD SAE 10 Lub.-oil
	No compression, valve clearance incorrect	Adjust valve
Engine runs erratically, no output	Fuel supply too low, filter clogged	Replace fuel filter element, check contents of tank
	Inadequate supply of combustion air	Engine cowling (housing) must have opening for fresh air supply
	Air in fuel system	Bleed
	Fuel pressure lines leaking	Tighten
	Valve clearance incorrect	Adjust valve
Engine stalls when warm	Gasoline in fuel (gas bubbles are formed)	Empty fuel tank, filter etc. fill with clean diesel fuel, bleed fuel system.

7.2.

FAULT	POSSIBLE CAUSE	REMEDY
Exhaust emits excessive smoke: 1) blue	Engine oil level too high	Drain off and re-check oil level possibly check angle of engine
	Valve clearance incorrect	Adjust valve clearance
	Poor compression due to seized or broken piston rings, worn valve guides etc.	Have engine overhauled
2) black	Engine overloaded	Reduce propeller diameter
	Excess starting fuel device cannot disengage itself as engine does not reach rated speed (overloaded)	Briefly move speed control lever into idling position, then slowly back to full load speed (overloaded)
Engine runs too hot	Engine compartment too hot	Fresh air must be adequately ventilated
	Too little cooling water	Open sea cock completely Clean sea water filter
	Too little cooling water	Clean water inlet strainer (outboard)
	Oil level too high	Drain oil; check engine inclination, respective sump capacity and dipstick markings with chart – page 25
	Waterpump aspirates air through cover of seawater filter or loose hose clamp	Wing nut not tightened, rubber gasket defective
	Cooling water line defective	Check water lines
	Pump impeller defective	Fit new impeller
	Cooling water pump rotates too slowly	Tighten drive V-belt
	Thermostat defective	Clean or replace. In case of doubt continue operation without thermostat.
	Injection nozzle defective	Have nozzle checked by mechan.
Feed rate of injection pump erratic	Examine by mechanic	

7.2.	FAULT	POSSIBLE CAUSE	REMEDY
	Engine runs too hot	Engine cooling passages scaled up or clogged with sludge	Dismantle and clean engine (service station)
	Oil pressure pilot lamp lights up	Pressure switch defective	Fit a new switch
		Oil pressure too low	Stop engine immediately. Check oil level
		Oil level too low	Top up
		Oil level too high	Crankshaft action creates oil foam which enters lub. oil pump causing pressure failure. Correct oil level.
		Oil filter leaky	Tighten or replace filter
		Oil filter clogged	Replace oil filter immediately
		Worn bearings	See service station
	Engine races	Centrifugal governor defective	Do not disengage propeller, return with lowest possible speed, apply to service station
	Engine knocks	Worn connecting rod bearings	See service station
		Valve sticks	Check valves (lubrication, clearances)
		Fuel delivery timing incorrect, piston tends to seize up	Stop engine, let it cool turn crank, in case of difficulty have boat towed
	Charge indicator lamp lights up during operation	Alternator speed too low	Tighten V-belt
		Terminals loose	Tighten terminals and cable ends
		Voltage regulator defective	Take to repairer
	Engine does not obtain its stated speed under load	Engine overloaded	Reduce propeller diameter

CORRECTION OF DIPSTICK ENGINE UNDER INCLINATION

Usual installation: Flywheel side (gearbox) lower than engine itself.

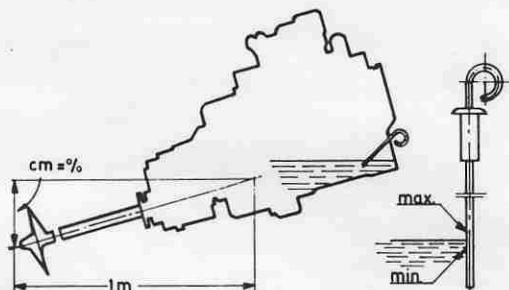

Markings on dipstick for horizontal installation (if any) have to be removed and re-adjusted in accordance to the engine slope. After complete installation of engine into boat the exact slope has to be determined. Then the crankcase has to be filled with exact quantity of lube-oil according to the slope and engine type (see chart below). Thus determined oil level should be marked on the dipstick with an auxiliary mark*.

5 mm above and 10 mm below this aux. mark the definite marks for "max" respectively "min" level should be filed in.

Inclination	Degree	0° - 10°	10° - 15°
	Percent	0% - 18%	18% - 26%
	cm	0 - 18	18 - 26
Lube-oil quantity in crankshaft housing ltr./US pints	K 30 M	1.4/3.0	1.0/2.1
	L 30 M	1.4/3.0	1.0/2.1
	A 40 M	2.6/5.5	2.0/4.2
	A 30 M ✓	2.0/4.2	1.5/3.2
	P 30 M	3.3/7.0	3.0/6.3
	S 30 M	3.3/7.0	3.0/6.3

R 30 M

This engine is supplied with red dipstick as standard. Does the actual slope not correspond with this colour (see chart below), another dipstick with the respective colour code has to be asked for.

Inclination	Degree	0° - 6°	6° - 12°	12° - 15°
	Percent	0% - 11%	11% - 21%	21% - 26%
	cm	0 - 11	11 - 21	21 - 26
Lube-oil quantity in cranks. housing I/US pint		2.3/4.8	1.8/3.8	1.5/3.2
Dipstick colour code		black	red	green

Caution: In V-2 engines (models R 30, P 30, S 30) the lube oil capacity applies **only** if the lube oil filter is replaced. Otherwise deduct 0,3 ltr. (0,4 qts.) from the amount shown.

*A chalk mark on the dipstick facilitates to note clean lube-oil.

RECOMMENDED HD-ENGINE LUBE-OILS

Other brands of HD-lube-oils of same quality not mentioned below can equally be used.

COMPANY	HD-Lube-oils according to API classification	
	CC	CD
AGIP	Agip F. 1 Diesel Gamma	Agip F. 1 Diesel Sigma
ARAL	Aral Kowal Motor Oel Aral Oele of the HD-line	Aral Kowal S 3 Motor Oel Aral Oel HD S 3
BAYWA	BayWa Motorenoil HD-Super BayWa Motorenoil HD-B	BayWa HD Superior S 3 BayWa Universal HD
BP	BP Energol HD BP Energol DS-B BP Vanellus/Vanellus-T	BP Vanellus S 3 BP Energol DS 3
CHEVRON	Chevron Delo Special Oil Chevron Delo 200 Motor Oil	Chevron Delo 300 Motor Oil
ELF	elf Performance	elf Disal HD 3
ESSO	Essolube HDX Essolube SDX	Essolube D-3 Esso Estor D-3
FINA	Fina Sona HD S 1 Fina Delta Motor Oil	Fina Solna S 6
FUCHS	Renolin HD Pena Pura HD Pena Pura HD Super Pena Pura Universal HD	Pena Pura HD Superior Pena Pura Universal HD
MOBIL	Mobil Delvac 1100 Mobil Delvac 1200	Mobil Delvac 1200 Mobil Delvac 1300
SHELL	Shell Rotella SX/Rotella TX Shell Melina Oele Shell Talona Oele	Shell Rimula CT
TOTAL	Total HD 1 B Total HPD	Total HD 3 Total HPD

Working condition, oil change interval and API-classification (oil quality):

Condition	Working Hours	API Classification	(Previous Designation)
Normal	50 - 60	CC	HD-SI or MIL-L-2104 A
Heavy	100 - 120	CD	HD-B or MIL-L-2104 B as well as MIL-L-2104 A SUPPLEMENT 1

FUEL SYSTEM

Fuel system with automatic bleeding device, employing fuel feed pump (2). Same continuously passes fuel through filter (4) to fuel injection pump (5). Part of the excessive fuel returns via banjo bolt with built-in throttle (8) and fuel return line (10) to fuel tank.

The return line connecting to tank should be situated as low as possible (5 cm above bottom), to prevent air penetrating fuel system via return line (10) when the engine does not run.

Bleed system by loosening screw (8), then pumping fuel transfer pump lever (3) until fuel alone (no bubbles of air) appears at (8). Tighten screw (8).

Drain plug (9) for drainage of condensing water and deposits in the tank, if any.

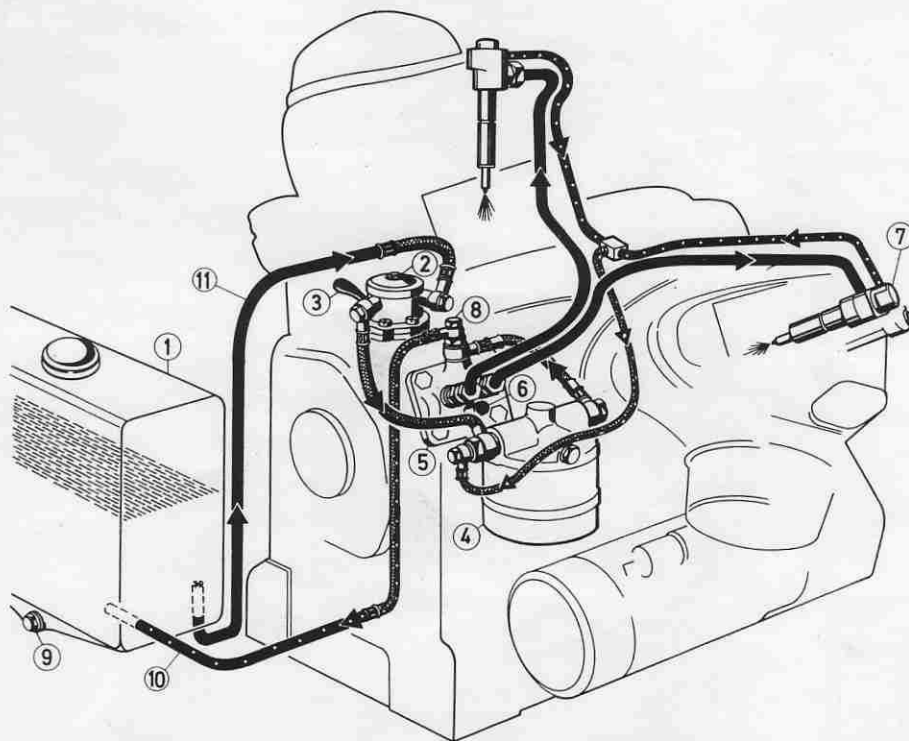

- | | |
|------------------------------------|--|
| 1 Fuel tank | 6 Push button for excess starting fuel |
| 2 Fuel feed pump (with pre-filter) | 7 Injection nozzle |
| 3 Primer (fuel feed pump) | 8 Banjo bolt with throttle |
| 4 Fuel filter | 9 Drain plug |
| 5 Injection pump | 10 Fuel return line |
| | 11 Fuel feed line |

FARYMANN MARINE DIESEL ENGINE TYPE "A 30 M"

Exhaust and cooling water installation diagram

Direct seawater cooling with water injection into exhaust **above** water line.

A = 100 mm (4")

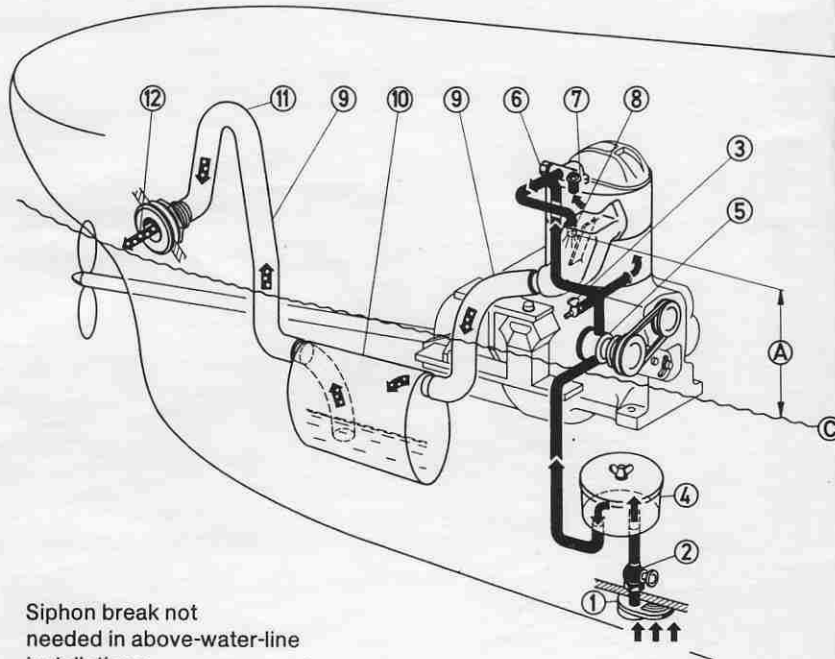

Siphon break not needed in above-water-line installations.

C = Water line

A = Minimum height above water line of water injection into exhaust line.

- | | |
|---------------------|---------------------------------------|
| 1 Seawater strainer | 7 Thermostat |
| 2 Sea cock | 8 Water injection |
| 3 Drain cock | 9 Rubber hose |
| 4 Seawater filter | 10 Water lift silencer |
| 5 Water pump | 11 Goose neck |
| 6 Temp. Connector | 12 Exhaust outlet (thru hull fitting) |

FARYMANN MARINE DIESEL ENGINE TYPE "A 30 M"

Exhaust and cooling water installation

Direct seawater cooling with water injection into exhaust **below** water line.

A = 300 mm (12")

B = 100 mm (4")

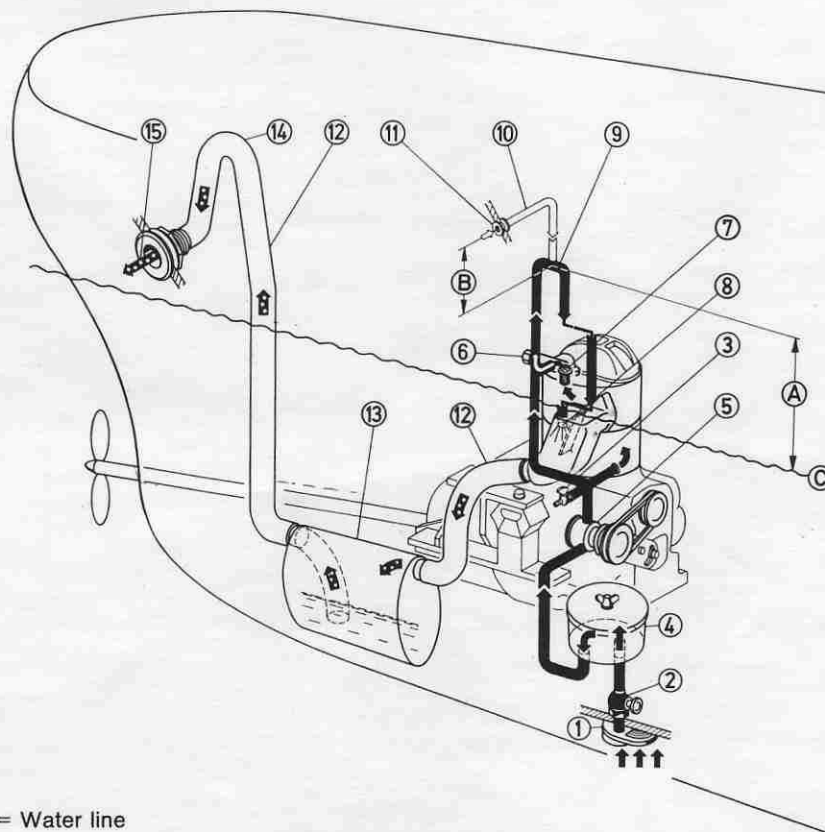

C = Water line

A = Minimum height above water line of water injection into exhaust line.

- | | | |
|---------------------|-------------------|-----------------------|
| 1 Seawater strainer | 7 Thermostat | 12 Rubber hose |
| 2 Sea cock | 8 Water injection | 13 Waterlift silencer |
| 3 Drain cock | 9 Water line with | 14 Gooseneck |
| 4 Seawater filter | T-fitting | 15 Hull fitting |
| 5 Water pump | 10 Breather line | (exhaust) |
| 6 Temp. Connector | 11 Hull fitting | |

ELECTRIC EQUIPMENT

Engine equipped with **key switch "ignition + start" (12)**, charging pilot lamp (10), water thermoswitch (7 + 9) and oil pressure switch (8 + 9). Oil pressure switch with V-twin engines only.

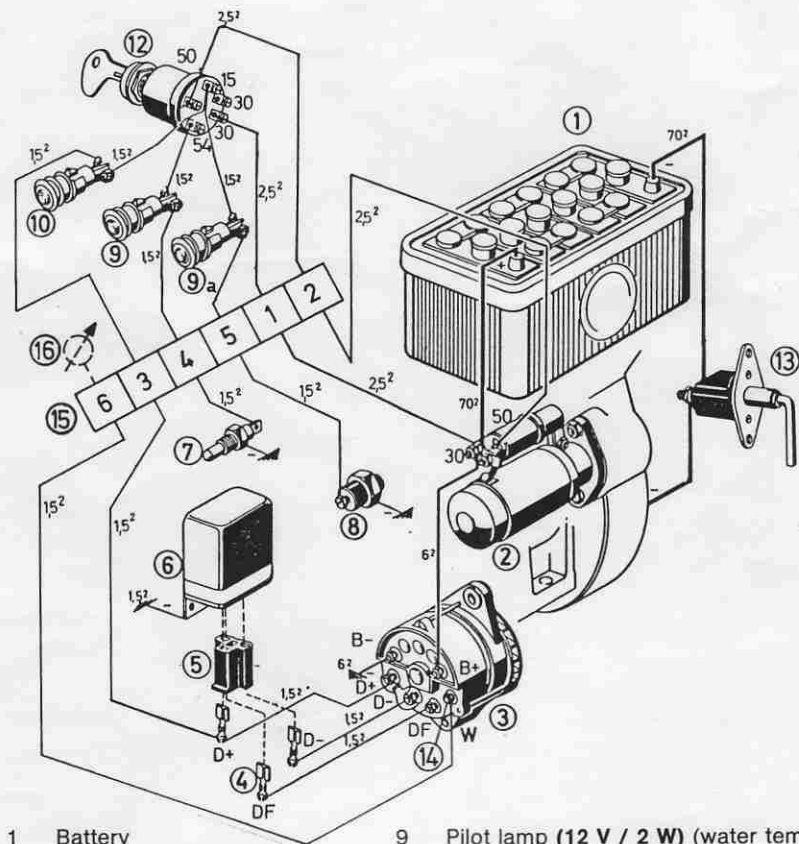

- | | | | |
|---|-------------------|----|--|
| 1 | Battery | 9 | Pilot lamp (12 V / 2 W) (water temp.) |
| 2 | Starter motor | 10 | Pilot lamp (12 V / 4 W) (battery charge) |
| 3 | Alternator | 12 | Key ignition starter switch (no key) |
| 4 | Plug socket | 13 | Main switch (battery) |
| 5 | Plug | 14 | W = Connector for electr. rev.-counter |
| 6 | Voltage regulator | 15 | Terminal clip |
| 7 | Thermoswitch | 16 | Tachometer |

ELECTRIC EQUIPMENT

Engine equipped with **lever switch** "ignition + start" (12) with charging pilot lamp (10) oil pressure switch (8 + 9a) and water thermostwitch (7 + 9). Oil pressure switch with V-twin engines only.

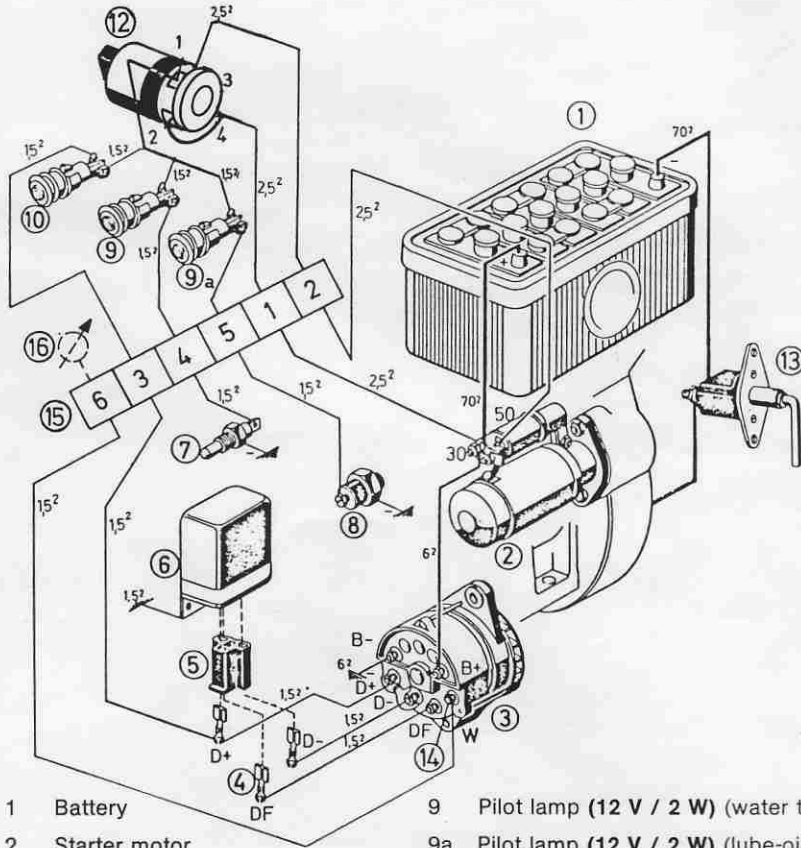

- | | |
|-----------------------|--|
| 1 Battery | 9 Pilot lamp (12 V / 2 W) (water temp.) |
| 2 Starter motor | 9a Pilot lamp (12 V / 2 W) (lube-oil pressure) |
| 3 Alternator | 10 Pilot lamp (12 V / 4 W) (battery charge) |
| 4 Plug socket | 12 Key ignition starter switch (no key) |
| 5 Plug | 13 Main switch (battery) |
| 6 Voltage regulator | 14 W = Connector for electr. rev.-counter |
| 7 Thermostwitch | 15 Terminal clip |
| 8 Oil pressure switch | 16 Tachometer |

If lever switch (12) (no key) is used battery main switch (13) is essential and must be fitted close to battery whilst cabin should be locked with key.