

# INTREPID YACHTS

## **OWNER'S MANUAL**

**Intrepid 9M and 35**

## TABLE OF CONTENTS

Letter of Welcome

Owner's Record

Introduction

### 1.0 Commissioning Information

- 1.1. Receiving, Launching and Commissioning Checklist
- 1.2. Warranty Procedure

### 2.0 Operation and Maintenance

#### 2.1. Hull and Deck

- 2.1.1. Construction
- 2.1.2. Maintenance
- 2.1.3. Bottom Paints
- 2.1.4. Hardware
- 2.1.5. Mast Step and Reinforcement

#### 2.2. Spars and Rigging

- 2.2.1. Spars
- 2.2.2. Rigging
- 2.2.3. Turnbuckles
- 2.2.4. Tuning
- 2.2.5. Sheets

#### 2.3. Sails

- 2.3.1. Sail Attachment
- 2.3.2. Reefing Mainsail
- 2.3.3. Sail Care
- 2.3.4. Battens
- 2.3.5. Optional Sails

#### 2.4. Bilge Pump

#### 2.5. Plumbing Systems

- 2.5.1. Fresh Water Tanks
- 2.5.2. Pumps
- 2.5.3. Head

#### 2.6. Through-Hulls, Valves and Seacocks

- 2.6.1. Seacocks

#### 2.7. Steering Gear

- 2.8. Electrical System
  - 2.8.1. Battery
  - 2.8.2. Battery Switch
  - 2.8.3. Instrument Panel
  - 2.8.4. Lightning Ground
  
- 2.9. Engine and Propulsion System
  - 2.9.1. Propeller Shaft Alignment
  
- 2.10. Interior Maintenance
  - 2.10.1. Cushions
  - 2.10.2. Ice Box
  - 2.10.3. Ports
  - 2.10.4. Sinks
  - 2.10.5. Head
  - 2.10.6. Woodwork
  - 2.10.7. General
  - 2.10.8. Stove
  
- 2.11. Maintaining Teak
  
- 3.0 Safety and Equipment
  - 3.1. Fire Extinguishers
  - 3.2. Fueling
  - 3.3. Weather Forecasts
  - 3.4. Boating Safety Organizations
  - 3.5. Charts
  
- 4.0 Winterizing
  - 4.1. Blocking the Hull
  - 4.2. Ice Box
  - 4.3. Stove
  - 4.4. Electrical System
  - 4.5. Propeller and Shaft
  - 4.6. Head
  - 4.7. Water Tanks
  - 4.8. Engine
  - 4.9. Fuel Tanks
  - 4.10. Covering

## LETTER OF WELCOME

Dear Skipper,

Welcome to the Intrepid Fleet!

You have joined the select group of sailors who recognize the quality construction and exceptional workmanship found in Intrepid Yachts. We appreciate your confidence in our product and assure you that, with proper care, you should have many hours of enjoyable sailing in your new Intrepid Yacht.

This manual has been prepared to assist you in getting to know your new yacht before setting sail for the first time. It also is a helpful guide to follow for proper care and maintenance in the future.

Please review the material carefully. You will enjoy your new Intrepid Yacht more if you are familiar with the design and construction of the boat and with the equipment used on board. Any questions you may have can be answered by your authorized dealer as he is a knowledgeable professional and is familiar with your new boat. He will continue to be your most important contact for information about your yacht and for any questions should they develop.

Again, welcome to the Fleet. We wish you many years and many miles of enjoyable sailing. May the wind always be fair.

Sincerely,

Andrew C. Vavolotis

INTREPID YACHTS OWNERS RECORD\*

Complete and save this form for your records and future reference.

Yacht Name \_\_\_\_\_ Home Port \_\_\_\_\_

Hull Identification Number \_\_\_\_\_  
(See introduction for location)

Dealer Name \_\_\_\_\_ Address \_\_\_\_\_

Salesman \_\_\_\_\_ Delivery Date \_\_\_\_\_

Date Commissioning Checklist/Warranty returned to  
Intrepid Yachts \_\_\_\_\_

\* \* \* \* \*

Owner's Name \_\_\_\_\_

Owner's Address \_\_\_\_\_

Registration Number \_\_\_\_\_

Engine Manufacturer \_\_\_\_\_

Model Number \_\_\_\_\_

Serial Number \_\_\_\_\_

\* It is recommended that you keep one copy of the information recorded above in a save place not on board your boat and an additional copy on board.

## INTRODUCTION

Intrepid Yachts are constructed in a recently remodeled facility located in East Taunton, Massachusetts. Intrepid Yachts is a division of Cape Dory Yachts, a long established leader of quality constructed fiberglass yachts, which has been in business for over fifteen years. Intrepid Yachts are assembled using modern methods, equipment, and materials obtained from the most reputable suppliers.

Our team of managers, supervisors and quality control personnel do their very best through every step of the construction process. We here at Intrepid Yachts strive to build boats of outstanding quality which will provide their owners with many years of sailing pleasure and retain high resale value.

The basic idea behind the formation of Intrepid Yachts was to bring to the sailing community a quality built yacht using contemporary standards and design practices that are now recognized as providing superior performance under sail. Without going to the extremes that are possible with a fin keeled yacht, we have been able to offer designs which are both performance oriented and suitable for racing, yet comfortable, attractive, and seaworthy, criteria for any yacht regardless of vintage.

We are aware of the tremendous forces a sailing yacht can generate and have taken great care to be sure that the high stress areas are substantially reinforced to give you trouble free performance under the worst conditions.

To protect your investment and to insure the enjoyment of your new Intrepid Yacht, we recommend that you read this manual carefully and complete the Commissioning Checklist contained in it with your dealer. This list will serve as a guide in determining that no loss or damage has occurred to your boat while it was being transported from the factory to the dealer, and that all equipment is in order when you accept delivery. the checklist is for your protection; insist that it be completed. One copy must be returned to Intrepid Yachts as a warranty registration. Once this registration process has been satisfactorily completed, you dealer will, if necessary, be able to file warranty claims for part or service. He cannot do so unless the checklists are completed and returned.

## IMPORTANT

Your Intrepid Yacht is identified by a hull identification number (HIN) on the right corner of the transom. This identifies the number of the hull and supplies the government officials with additional information concerning the builder and the year of manufacture. There is also a builder's plate with the hull number located on the forward hatchway trim. In addition, there are serial numbers on your boat's engine (see the engine manufacturer owner's manual) and on some of the accessory equipment which you may elect to have installed.

We recommend that you record these important numbers carefully and keep copies of them at home and aboard (see "Owner's Record" form). These numbers and an accurate description of your property, in the event of theft, could be essential to their recovery.

Marking an inconspicuous place such as the inside of a locker, underside of a door or drawer, or the base of the mast with your initials, social security number, or other unique "brand" may also aid in the prompt identification of your property, should the need to do so ever arise.

## 1.0 COMMISSIONING

Intrepid dealers are chosen because they are knowledgeable professionals. Since you are bearing the launching and commissioning expenses of your new yacht you have a right to expect a thorough and professional job.

Please note that the checklists provided in this manual are to assist you and your dealer with the first launching of your boat. In subsequent years, you may wish to review this list in preparing your boat for launching.



1.1 DEALER'S COMMISSIONING CHECKLIST – PAGE 1

Model \_\_\_\_\_ Hull Number \_\_\_\_\_

Owner's Name and Address \_\_\_\_\_

Dealer \_\_\_\_\_

Date Sold \_\_\_\_\_ Date Launched \_\_\_\_\_

1.1	<u>Date</u>	<u>Initials</u>	<u>Receiving Record</u>
1.	_____	_____	All items on receiving checklist received in good order. Dealer should notify factory within to (10) days of receipt, of any shortages or damaged goods.

PRE-LAUNCH CHECKLIST

2.	_____	_____	Visually check underwater hull surface for any damage sustained during trucking or handling.
3.	_____	_____	Through-hulls all tight and clear of any foreign objects.
4.	_____	_____	Seacocks and valves all closed. Hose clamps tight.
5.	_____	_____	Check two propeller retaining nuts for tightness. Cotter pin in place and bent over.

Record propeller information below:

Diameter \_\_\_\_\_ inches

Pitch \_\_\_\_\_ inches

Rotation \_\_\_\_\_ left or right hand

# of blades \_\_\_\_\_ 2, 3 or folding (optional)

6.	_____	_____	Rudder swings freely side to side.
----	-------	-------	------------------------------------

7.	_____	_____	Stuffing box packing adjusted.
----	-------	-------	--------------------------------

WHITE-Return to Intrepid Yachts; YELLOW-Owner's Copy; PINK-Dealer's Copy  
DEALER'S COMMISSIONING CHECKLIST – PAGE 2

- 8. \_\_\_\_\_ Bottom under cradle bulkheads sanded, primed and painted.
- 9. \_\_\_\_\_ Bilge dry.
- 10. \_\_\_\_\_ Bilge pump connections okay and handle on board.
- 11. \_\_\_\_\_ Check deck and hull for any chips in gel coat.

POST-LAUNCH CHECKLIST

- 12. \_\_\_\_\_ Immediately after launching, check bilge for water. If water is present, check all through-hulls and stuffing box.
- 13. \_\_\_\_\_ Open seacocks one at a time and check for leaks.
- 14. \_\_\_\_\_ Check stuffing box. It should drip water slowly, approximately one drop every 10 seconds while running to insure that the bearing and packing gland are lubricated by water.
- 15. \_\_\_\_\_ Check battery switch and electrical system operation.
- 16. \_\_\_\_\_ Check battery electrolyte and charge level.
- 17. \_\_\_\_\_ Check head operation.
- 18. \_\_\_\_\_ Check bilge pump operation.

ENGINE START-UP CHECKLIST

The following checklist is not intended to replace the engine manufacturer's manual. Refer to that manual before starting the engine.

- 19. \_\_\_\_\_ Check engine and transmission oil level and condition.
- 20. \_\_\_\_\_ Check belt tension on all belt driven components.

WHITE-Return to Intrepid Yachts; YELLOW-Owner's Copy; PINK-Dealer's Copy  
**DEALER'S COMMISSIONING CHECKLIST – PAGE 3**

- 21. \_\_\_\_\_ Check that cooling water intake seacock is open.

- |     |  |  |  |
|-----|--|--|--|
| 22. |  |  | Check to see that all clamps on exhaust hose are tight (on Yanmar engines make sure that exhaust hose enters water lock at location marked "in").    |
| 23. |  |  | Check engine mount nuts for tightness.   |
| 24. |  |  | Check shift and throttle cable connections.  |
| 25. |  |  | Check shift and throttle operation.  |
| 26. |  |  | With coupling disconnected, check prop shaft alignment using feeler gauges. See manual for instructions and tolerances.                              |
| 27. |  |  | Check prop shaft set screws, and see that they are wired in place.   |
| 28. |  |  | Start engine according to manufacturer's recommendations. Failure to start may be due to air in fuel lines. Refer to manual for bleeding directions. |
| 29. |  |  | Immediately after engine starts, check to see that water is coming out of transom exhaust port.  |
| 30. |  |  | Check gauges and/or warning lights.  |
| 31. |  |  | Check entire system for water, oil, fuel, or exhaust leaks. Note: sealers and paints may burn off as engine heats up, causing a burning odor.        |
| 32. |  |  | Recheck stuffing box.  |
| 33. |  |  | Report any unusual noises or vibrations to factory immediately. Do not continue to run engine if any are present.                                    |

WHITE-Return to Intrepid Yachts; YELLOW-Owner's Copy; PINK-Dealer's Copy  
 DEALER'S COMMISSIONING CHECKLIST – PAGE 4

RIGGING CHECKLIST

- 34. \_\_\_\_\_ Check all fasteners on spars for tightness.
- 35. \_\_\_\_\_ Reeve halyards.
- 36. \_\_\_\_\_ Attach stays, shrouds, spreaders and topping lifts.
- 37. \_\_\_\_\_ Check all clevis pins and cotter pins for security. tape all potential chafe points including spreader bases and ends.
- 38. \_\_\_\_\_ Check wiring of combination deck and bow light. Be sure bulbs work.
- 39. \_\_\_\_\_ Step mast and rigging.
- 40. \_\_\_\_\_ Check all rigging for length.
- 41. \_\_\_\_\_ Check all clevis and cotter pins for security. Be sure the locking nuts on the turnbuckles are secure. Tape all potential chafe points.
- 42. \_\_\_\_\_ Tune rigging to proper tensions.
- 43. \_\_\_\_\_ Attach boom, sheets, blocks, oars, reefing lines, topping lifts, etc.
- 44. \_\_\_\_\_ Wire bow and deck lights.

MISCELLANEOUS CHECKLIST

- 45. \_\_\_\_\_ Fill water tank(s) and check operation of all pumps and drains.
- 46. \_\_\_\_\_ Fill alcohol tank. Check for leaks and test operation of stove.
- 47. \_\_\_\_\_ Water test ports and hatches.
- 48. \_\_\_\_\_ Recheck all through-hulls, valves, seacocks, host clamps, hoses, and stuffing box.

WHITE-Return to Intrepid Yachts; YELLOW-Owner's Copy; PINK-Dealer's Copy  
DEALER'S COMMISSIONING CHECKLIST – PAGE 5

- 49. \_\_\_\_\_ Bend on sails.
- 50. \_\_\_\_\_ Interior appointments complete.
- 51. \_\_\_\_\_ Optional equipment installed and operational.
- 52. \_\_\_\_\_ Owner's packet, ship's papers, and ignition key given to owner.
- 53. \_\_\_\_\_ Checklist (warranty registration) ready for mailing to factory.

Owner \_\_\_\_\_

Date \_\_\_\_\_ Within seven days of launching,

RETURN CHECKLIST TO:  
Intrepid Yachts  
160 Middleboro Avenue  
East Taunton, MA 02718

WHITE-Return to Intrepid Yachts; YELLOW-Owner's Copy; PINK-Dealer's Copy

## 1.2 WARRANTY NOTIFICATION PROCEDURES

After commissioning, you as an owner should not expect problems to develop with your Intrepid Yacht. However, should you need assistance, there is one very important thing to do ... CONTACT YOUR INTREPID DEALER.

Your Intrepid dealer is a knowledgeable professional who is familiar with your boat and capable of answering most of the questions which you may have. He will communicate any problems or inquiries which you may have directly to our company so that we can both work together toward an expeditious and satisfactory solution. Your dealer is not, however, authorized by Intrepid Yachts to consent to repairs or the replacement of parts without the express written approval of Intrepid Yachts.

## 2.0 OPERATION AND MAINTENANCE

The following sections of this manual describe briefly the structural and functional systems of your Intrepid Yacht. We have also provided you with operating and maintenance instructions where we thought these would be helpful. These instructions are to serve as a guide only. For more extensive information, consult the publications available and seek the advice of your dealer.

### 2.1 Hull and Deck

#### 2.1-1 Construction

Your Intrepid Yacht has been fabricated using the widely accepted glass-reinforced-plastic system. This system utilizes “fibrous glass” in the forms of mat and various weight cloths and woven rovings bonded together with polyester resins. Fiberglass is one of the stronger and most easily maintained boat building materials. It is not subject to organic decay as is wood.

Intrepid Yachts are constructed from four major fiberglass components: hull, deck, bunkliner, and headliner. The bunk and headliner units form the interior of the boat and are of lighter construction than the hull and deck.

The hull of your Intrepid was fabricated in layers beginning with gel coat, mat and woven roving. The number of plies in the hull laminate vary depending on the size of the hull and the location in the hull. Decks are laminated using the same basic system as the hulls, but end-grain balsa core material is added in certain areas to increase the stiffness of flat surfaces.

The bunkliner is securely bonded to the hull along the entire keel cavity resulting in approximately 3” of fiberglass where the keel bolts pass through the hull.

#### 2.1-2 Maintenance

Fiberglass is one of the most maintenance-free materials utilized today in boat construction. If given proper care and treatment, the gel coat surface will look new for years. If not maintained, it will eventually turn to a flat, chalky texture.

We recommend that you wash the exterior fiberglass surfaces of your boat several times each season with mild soap and plenty of warm fresh water. Rinse liberally with fresh water. After the boat has dried, use a good quality fiberglass cleaner in paste form, follow this process with a wax or polish prepared for marine use. A fiberglass cleaner with a very gentle abrasive in it may help remove minute scratches and surface wear. The continued use of cleaners containing abrasives will gradually erode the gel coat surface. Marine wax will fill small scratches and provide a glossy finish.

Stubborn stains may be removed with fiberglass cleaner in some instances. More difficult stains may be worked out with judicious use of a very mild abrasive powder such as Bon Ami. Stubborn tar and petroleum stains may be removed

with careful application of acetone. (Acetone is a powerful and extremely flammable solvent which is available in most paint and hardware stores.)

Stress or “spider cracks” are a common occurrence on the fiberglass boats of even the most careful skippers. Most of the time, these cracks represent no structural problem and are limited to the gel coat surface. If you have any doubt about the seriousness of any crack, consult your dealer. Minor gel coat repairs are not difficult and a reasonably handy person with a little study and practice can make adequate cosmetic repairs. Structural fiberglass repairs, however, are best left to the experts.

If for any reason you desire to apply paint to areas of the boat other than to the bottom or boot top, seek the advice of qualified personnel at a boat yard in your area for information about the latest development in chemically-based paints for fiberglass, and the recommended surface preparation procedure.

### 2.1-3 Bottom Paints

Your Intrepid Yacht was painted with Dolphinite #9303 Dark Blue anti-fouling bottom paint before it left the factory. The area under the cradle bulkheads and keel supports may require additional painting prior to launching. These areas should be well sanded with 50 grit paper and washed with solvent to remove wax prior to painting.

In certain geographical areas some bottom paints work much better than others. If you intend to repaint the bottom of your boat, seek the advice of your dealer or knowledgeable local boat owners on what brand of bottom paint works well in your area. Caution: not all bottom paints are chemically compatible. Be sure to tell your paint dealer what paint is currently on the bottom of your boat to be certain that you purchase compatible anti-fouling paint. The Dolphinite bottom paint is a vinyl-resin based vehicle.

### 2.1-4 Hardware

The deck hardware items on your Intrepid Yacht were engineered for their intended purposes.

Since many deck hardware items are expected to withstand considerable strains, they are bolted through the deck and through a back-up reinforcement where required. The bolts securing these items should be checked frequently to be certain that they are still tight. Be careful not to over tighten any fastener thereby causing it to fail or be reduced in strength.

The judicious use of a silicone-type product on sail, genoa, and traveler tracks works well to keep these running free in a salt air environment. Sheaves should be disassembled occasionally, washed and well lubricated with a thin oil.

Turnbuckles, stanchions, rails, and other stainless steel hardware will discolor in a salt air environment. Keeping stainless steel cleaned and polished using a marine



wax provides protection and keeps it free of rust stains. Frequent cleaning and washing with fresh water will keep your spars and hardware in good condition, and will help to keep your sails clean.

Lubrication on a regular basis is essential to keep winches operating freely. The roller bearings of these winches should be cleaned and regreased (using light grease) about every three months. Caution should be exercised in the quantity of grease used, as excessive amounts may clog the ratchet mechanism. All winches should be dismantled, cleaned, and inspected at least once a year. It is recommended that winches be covered when not in use.

#### 2.1-5 Mast Step

The mast step areas of Intrepid Yachts are carefully engineered to transmit the loads set up by the rigging evenly to the hull with no local stress concentrations. For boats supplied with deck stepped masts, a compression member transmits the load directly to the keel area of the hull. For boats with keel stepped masts, localized reinforcement is provided to distribute the load over a large area of the hull. All mast step castings are drilled and tapped into a metal plate bedded solidly into the glass laminate.

### 2.2 Spars and Rigging

#### 2.2-1 Spars

Masts, booms, and optional spinnaker poles on all Intrepid Yachts are made of high-grade extruded aluminum. All spars are anodized; unfortunately anodizing is a semi-permanent process, but still the best means of protecting aluminum. After several years of hard exposure to salt, spray and sun, the protective virtues may diminish and a protective paint or film may be applied to the mast. However, anodized spars have been used for many years untreated with no apparent harm.

As a general rule, aluminum masts require minimal care and maintenance. When they are removed from the boat for the winter, they should be thoroughly washed with plenty of fresh water, and after all halyards and lifts have been neatly tied-off to prevent tangling and fouling, a thorough inspection should commence. Start at the base of the mast. Water will collect here if the drain hole in the mast step has not been kept clear. This may hasten the breakdown of the anodizing and start the corrosion process. If water has collected and caused corrosion, clear the mast step drain hole and refinish the mast base or heel. Waxing will help preserve anodizing.

Proceed up the mast noting any areas that are scratch or abraded. If these are small they may be covered with a clear lacquer of a mastkote type product to keep corrosion from starting or spreading. Sometimes it is recommended that you apply to the mast a good hard wax as this helps to protect it further. As you proceed up the mast, check every cleat and fitting for tightness, and for corrosion which may have begun in the screw holes. Make certain that no bronze, brass, or

iron fastenings are used on the aluminum as these metals are incompatible and electrolytic decomposition will start at once.

Check the tang fittings for lower shrouds and mounts for the spreaders as you proceed up the mast. Carefully check all tangs, straps and fittings at the masthead.

Examine the main and jib halyard sheaves for signs of wear or jamming. If you see anything that looks at all unusual, ask your dealer or local boatyard for assistance. Be certain that the boom is inspected carefully, with particular attention to the gooseneck fittings, sheet blocks and bales. The combination bow and deck light should also be checked. It is good practice to change the bulbs every year as a mid-season failure is very difficult to correct. Record bulb sizes and carry spares aboard your boat.

The spreaders that support the upper shrouds should be inspected. They are designed to angle slightly upward to best support the mast in column. The inboard and outboard ends should be covered with chafe tape or spreader boots to prevent tearing sails or halyards. If any damage is sustained during mast stepping or winter storage, replace the spreader. DO NOT sail with defective spreaders, spar or hardware.

## 2.2-2 Rigging

Standing rigging consists of shrouds and stays which support the mast in an upright position. Running rigging is used to hoist or trim sails. Standing rigging requires attention, as a failure could result in the loss of a mast. Most failures occur from lack of attention, poor tuning or improper maintenance rather than a structural failure.

Before stepping your mast each season inspect all standing rigging thoroughly. Starting at the top of the mast, systematically check each upper shroud and stay tang and be certain that each clevis pin is secured with a cotter pin properly in place and bent over. Wipe down each shroud and stay with bronze wool dipped in a solution of water and mild detergent. The bronze wool will catch any broken wire in the rigging, calling attention to potential trouble; it will not leave steel particles to rust and soil your sails. Follow the bronze wool with a piece of terrycloth sprayed with a water-dispersing agent, such as CRC or WD-40.

Next, see that the spreaders are firmly fastened in place, and that the upper shrouds are locked in place on the grooved end of the spreader with a short length of stainless steel wire. You should use a spreader boot or some other form of chafing gear to protect your sails from the spreader tip. Check the mast tangs, clevis pins and cotter pins for the lower shrouds and stays. The tangs for the lower shrouds are designed to allow for some movement in them, so do not overtighten the tang bolt.

Prior to stepping the mast, be sure the halyards are properly reeved. Tradition dictates that the main halyard's hauling part is always secured to the starboard side of the mast, and the jib halyard is secured on the port side.

After checking each piece of standing rigging for broken wires, rust spots, and for secure clevis and cotter pins, inspect the swaged terminal fittings at the ends of each shroud and stay. These fittings should all be examined, using a magnifying glass, for any hairline cracks. These cracks sometimes develop after water has entered the body of the fitting (by following the lay of the wires) causing the wire to corrode and expand. Although this problem is more prevalent in the southern latitudes, many owners seal the space between the wire and the swages with bees wax. Turnbuckle boots are also quite popular, but are not recommended by Intrepid Yachts as they cover the turnbuckles which should be inspected frequently. We do not recommend oiling or greasing the swage fittings as a means of preventing water running inside them.

Report to your dealer any fittings that you find to be defective. Wire and fittings with any of the following defects require replacement: kinked wire, wire with broken strands, cracked swage fittings, bent turnbuckles, turnbuckles with stripped threads, clevis pins with grooves worn in them, and tangs or other fittings with distorted holes. The existence of any of the aforementioned conditions should be investigated, the reasons for them determined, and corrective action taken.

After completing the above inspection, the mast may be stepped and the standing rigging secured to the chainplate. In all Intrepid Yachts the upper shrouds are attached to the chainplate in direct line athwart from the mast step. Lower shrouds are attached fore and aft of the upper.

All running rigging on Intrepid Yachts is Dacron. It requires only protection from chafe and the ultraviolet rays of the sun. Stow in neat seamanlike coils when not in use so that it will run freely without kinks or hockles when it is needed. A rinsing in fresh water at the end of the sailing season is recommended.

### 2.2-3 Turnbuckles

The Intrepid 9 Meter is equipped with closed-body integral-toggle stainless steel turnbuckles. Prior to every sail, all turnbuckles should be checked to see that they are properly adjusted (see section 2.2-4, Tuning) and above all, locked, so that they will not loosen. The two lock nuts should be tight against the barrel. The threaded sections above and below the barrels may be taped once the turnbuckles are adjusted and locked in place. This tape serves as an immediate indicator if the turnbuckles are loosening. Engine vibration and even wave action at a mooring or slip are enough to allow an improperly locked turnbuckle to work loose. Some skippers thread stainless steel seizing wire through the hole in the center of the barrel to the toggle as a back-up to the lock nuts. The threads on the studs and barrel of all turnbuckles are both left and right handed. This is required for the turnbuckle to serve its tightening function. Spare locking nuts should be carried aboard in both left hand and right hand configurations. Occasionally, during the

season, you should completely disassemble and inspect all turnbuckles. Do not attempt to do this when sea or wind conditions are placing strain on the mast. The shroud turnbuckles (upper and lower sidestays) may be disconnected and inspected one at a time. The remaining shrouds will provide adequate mast support.

The Intrepid 35 is equipped with open body integral turnbuckles. The two cotter pins should be inserted and spread open. The threaded sections above and below the barrels as well as the cotter pins should be taped once the final adjustments have been made.

Prior to disconnecting headstay and backstay turnbuckles for inspection, special measures to support the mast are necessary. This can be accomplished by using the halyards as temporary stays. Attach the jib halyard to the jib tack shackle; haul it in tight, cleat it. This will temporarily replace the headstay, so that you may disassemble the turnbuckles for inspection. Lead the main halyard aft to a stern cleat and follow the above procedure to check the backstay turnbuckle.

The pipe or barrel section of the turnbuckle should be backed off entirely from the top and bottom sections. All threads should be carefully inspected both for broken or worn threads as well as rust, corrosion or breakdown of the metal itself. The threads in the “pipe” should be inspected as well as those on the long, threaded ends. The locking nut should also rotate freely. Prior to assembly, lightly lubricate the ends, barrel and locking nuts with waterproof grease.

The enclosed insert from Spartan Marine Products, Inc. indicates the maximum distance turnbuckles should be opened. The “Y” dimensions listed apply only to turnbuckles with properly centered barrels. Turnbuckle barrels can be centered by measuring the threads exposed above and below the barrel and adjusting accordingly prior to securing the turnbuckle to the chainplate.

#### 2.2-4 Tuning

The purpose of tuning the rig is to adjust the center of effort of the sail plan fore or aft to obtain a slight weather helm in moderate winds, and to keep it straight without “hooks” to port, starboard, fore or aft. Properly trimming the rig is an important process which should be attempted only by qualified personnel; consult your Intrepid dealer.

The fore and aft alignment of your mast can be checked by comparing it to a vertical structure such as a radio tower, chimney, etc. Before checking the mast alignment in this manner, be certain that the boat is resting on her design water line. If the mast is leaning for or aft, ease the turnbuckle toward which the mast is leaning and take up a corresponding number of turns on the opposite turnbuckle. (Note: When adjusting turnbuckles, never use excessive force or the turnbuckle may be contorted.) Always prevent the upper threaded turnbuckle stud from turning. Headstays and backstays should never be taken up so tightly that they will not “give” an inch or so if you pull on them with moderate force.

Upper shrouds should also be tightened equally and have about an inch of “give” to them. Forward lower shrouds should have one to two inches of “give”, and the aft lowers slightly more.

Under no circumstances take up the rigging to bar tight tension. Both the mast and the boat can be severely damaged by excessive tension.

Fine tuning of the rig can be completed after the boat has been sailed, and may have to be done again after the boat has been out in strong winds. When sailing, it is important that the mast remain straight and as nearly in column as possible at all times. While sailing close hauled, sight up the mast track and note any mast curve. Does the mast appear to be falling off to leeward at the top, or does it look to windward? Repeat this procedure on the opposite tack.

If the masthead is falling off on both tacks, the forward lower shrouds are too tight and the upper shrouds are too loose. If the masthead hooks to windward, the upper shroud is too tight in relation to the lower on the same side. When sailing to windward, the forward lower shrouds bear a greater load than the after lower shrouds; however, the after lower shrouds on the windward side should never be loose. All shroud tuning should be done from the leeward side. If the rig seems to be equally balanced when you begin, duplicate every half turn from side to side.

Be sure that every locknut is tightened after adjusting turnbuckles. Check to see that all cotter pins or rings are in place and that all sharp edges are taped.

## 2.2-5 Sheets

Swapping sheets end for end will extend the useful life of a sheet that has started to chafe where it passes a sheave or engages a cam cleat.



## 2.3 Sails

### 2.3-1 Sail Attachment

The mainsail luff has plastic slugs which are inserted into the track on the after side of the mast. After the sail slugs are inserted in the track, close the gate and install the cotter pin. Insert plastic slugs at foot of main into boom sail track.

**Diagram A** – Illustrates an Adjustable Outhaul System (9 Meter only)

A single block with a becket is attached to the boom end. The outhaul line is attached to the becket and led through the clew grommet, then back through the single block. This establishes a stronger and tighter outhaul with less effort.

The adjustable outhaul should be utilized in trimming the foot of the sail.

Intrepid 35 Outhaul System:

The Intrepid 35 has a four-part internal outhaul system installed at the factory. To service or maintain the system both a 3/8” bolt through the boom and the outhaul casting must be removed.

**Diagram B** – Illustrates and Adjustable Boom Topping Lift (9 Meter only)

A 1/4” bolt is run through the eyesplice attaching the topping lift to the aft portion of the masthead. The topping lift adjuster is knotted or spliced to the boom end and run through the single block which is spliced at the end of the topping lift. Leading back to a cheek block on the starboard side of the boom, it adjusts the boom to your desired height and cleats fast on the starboard side of the boom.

Intrepid 35 Topping Lift:

The Intrepid 35 topping lift system is similar to the Intrepid 9 Meter except that the becket block is attached to the topping lift and both a single block and a cheek block are attached to the boom giving greater mechanical advantage.

### 2.3-2 Reefing Mainsail

“Jiffy Reefing” is used on Intrepid Yachts. Remember: IF YOU ARE THINKING ABOUT WHETHER OR NOT TO REEF, IT’S TIME TO DO IT. Being over –canvassed is hard on crew and boat, potentially dangerous, and will not make the boat go any faster.

“Jiffy Reefing” is the more traditional method of shortening sail. You do not have to raise the main to its full height on the mast to properly reef, but it is somewhat easier if you do as it keeps the sail out of your way.

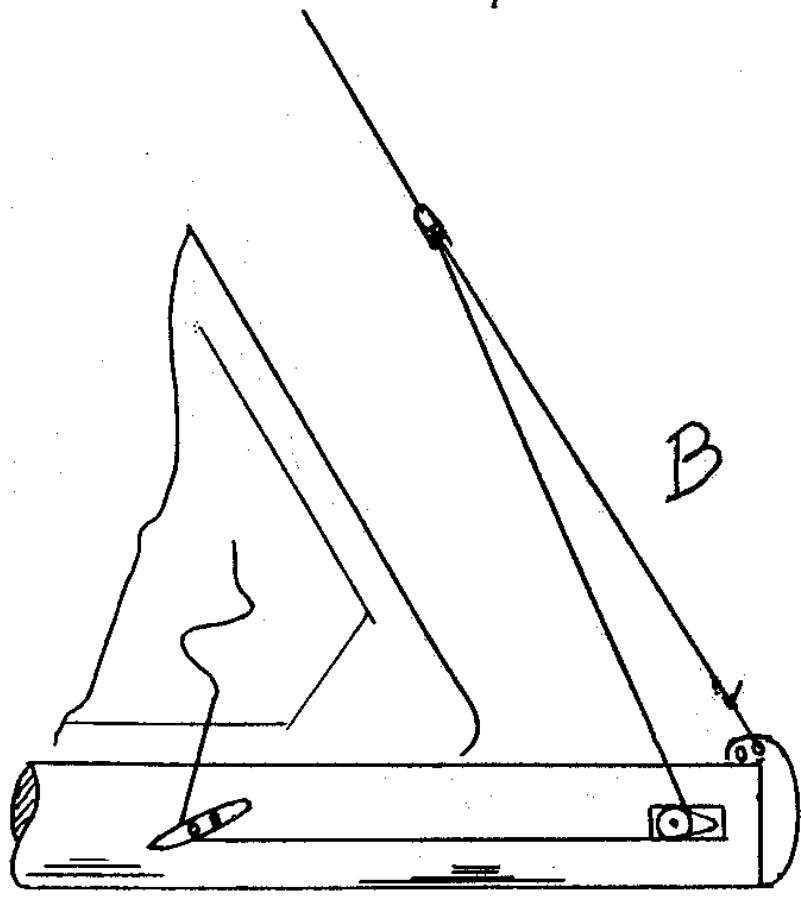
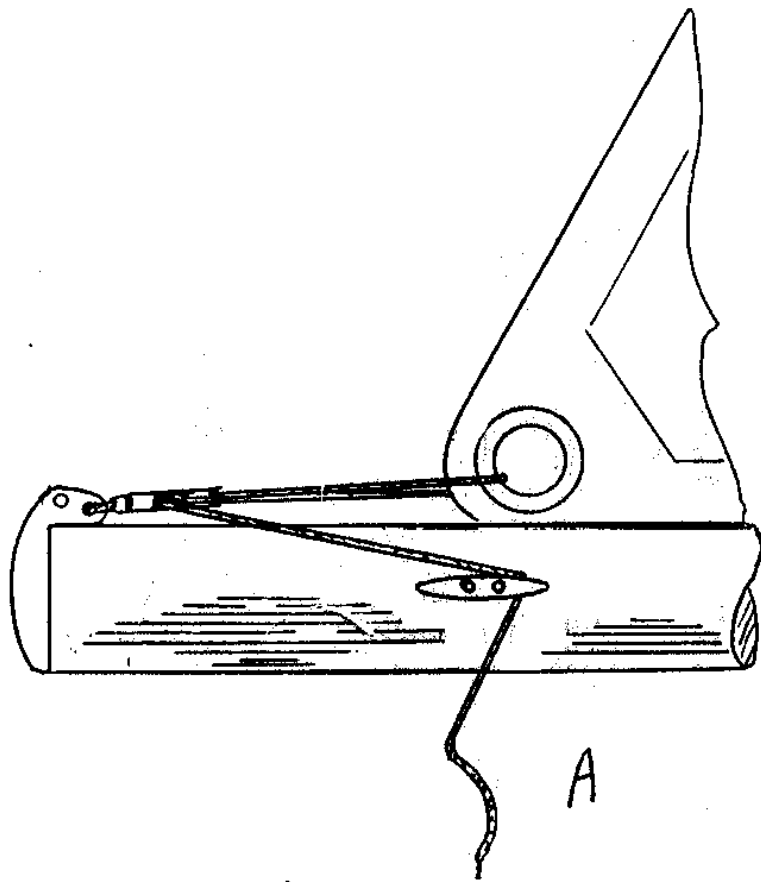



# QUICK REEFING\*

As the modern offshore racing yacht rapidly becomes more sophisticated, and offshore racing itself becomes more challenging, hardware and sail handling systems are refined and developed to make yachts faster and easier to operate. Perhaps the most important development in the area of sail handling has been Quick Reefing.

Time was when the call to reef meant a sacrifice of speed, time and lots of crewmen on deck. Quick Reefing has changed all this. It is very fast, requires few hands and retains proper sail shape.

Although sophisticated refinements have been developed, the basic system is simple and effective. Installation or conversion is easy, and the benefits of this fine system are appealing to racer and cruiser alike.

\*Also known as California Reefing, Slab Reefing or Jiffy Reefing.

## Method A

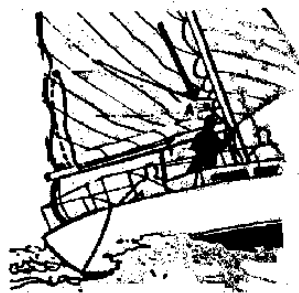
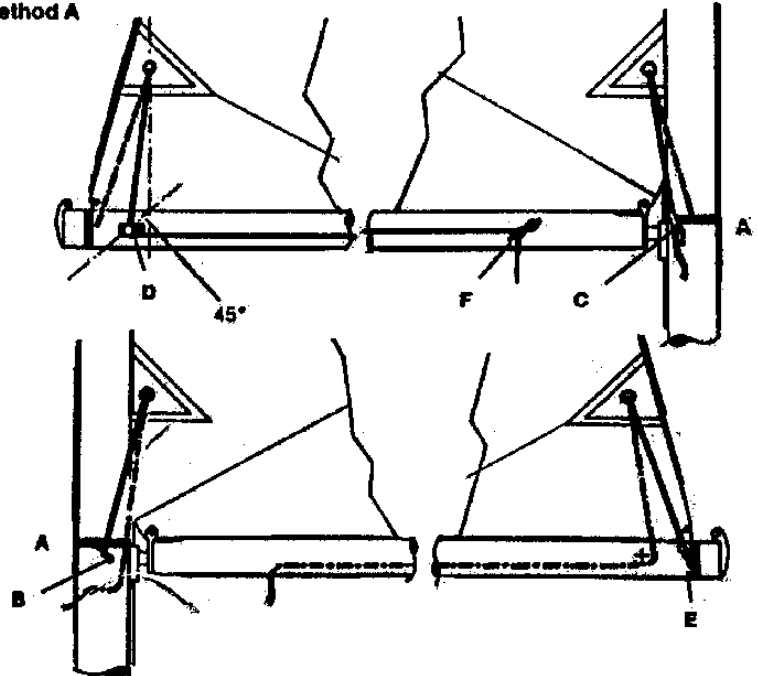

1. The halyard is released and the reef tack downhaul (A) is tightened until the reef cringle is drawn down to the gooseneck, then cleated. (Pre-marking the halyard provides a good reference when releasing)

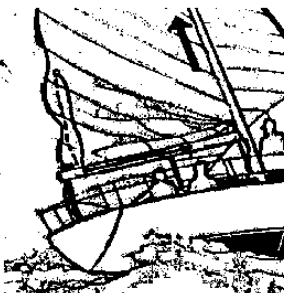

2. The main halyard is tightened up. Note: The mainsheet should be slacked only if necessary. (Usually when reaching)

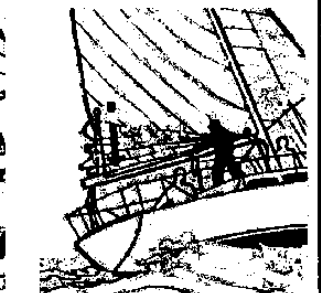

3. The reef clew outhaul (B) is tightened up to the reef cringle and cleated. With practice, a Quick Reef can be executed in between 15 and 30 seconds on a boat of 40ft. in length!

## Method B

A simplification of the basic quick-reefing system has been developed recently. A gooseneck hook replaces the reef tack downhaul and a single ended cheek block and sliding loop arrangement holds the clew. A production boom and gooseneck featuring this arrangement is available from Schaefer Spars.

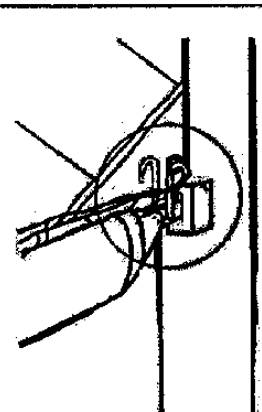
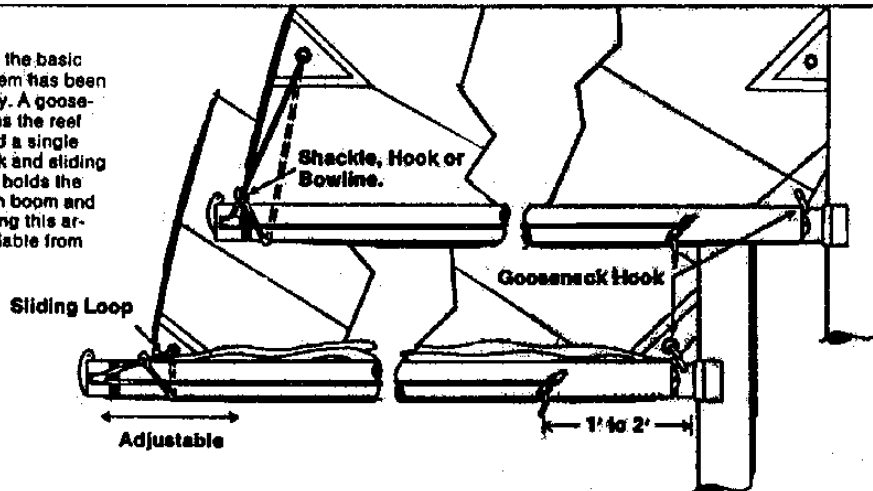

The reef tack cringle can be hooked quickly onto the gooseneck hook as the halyard is released.

Reeve the reefing lines through the reefing cringles – the grommets on the luff and leech that will become your new tack and clew. Pull the tack down to the top of the boom. Make the line fast to the cleat on the mast. Next, haul on the clew line, pulling the clew down aft. The clew line runs from a padeye up through the grommet, down to a cheek block and forward to a cleat. The key to this type of reefing is to have sufficient tension on the foot of the sail. When the clew has been pulled out and the foot is tight, make the line fast around the cleat on the boom.

There are reef “points” in the mainsail of Intrepid Yachts fitted with “Jiffy Reefing”. Use 18” lengths of 1/4” line and run them through each reef point. Lead the line through the reef point, under the foot of the sail and tie the reef lines in a reef knot. This will keep the unused sail out of the way and reduce windage. It is also the seamanlike procedure.

To shake out the reef, release the lines through the reef points, stow them, and release the reef line through the reefing cringle that is serving as your clew. Then release the reef line on the reefing cringle for the tack, and hoist the mainsail so that the luff is tight.

During the reefing exercise, the topping lift may need to be adjusted. It should always have some play in it under normal sailing conditions, but during reefing, some prefer to take up on the topping lift prior to beginning to reef. If this is done, be sure to slacken it when the reef is completed.

Generally speaking, reefing is desirable when you find yourself heeling more than 20° or wish to slow the boat down to keep it manageable in heavy airs. When going off the wind, the boat will probably sail as well running under headsails alone, since the reefed main will usually blanket the headsail. You may wish to leave the mainsail reefed, furled and ready to hoist when you change direction to windward.

The following explanation of “Quick Reefing” is out of the catalogue of Schaefer Marine Products of New Bedford, Massachusetts, and is reprinted here with their permission.

### 2.3-3 Sailcare

Sails should be protected from chafe by padding spreaders and other gear or by installing chafe patches on the sails themselves. Spreader and shrouds can chafe genoas and other overlapping jibs when those sails are sheeted in tightly and can chafe the mainsail when running before the wind. Topping lifts frequently chafe the leach of mainsails.

Inspect your sails frequently and take care of chafed stitching or small tears before they become a major problem. A small ditty bag with some thread and a few sail maker’s tools on board can come in handy and save you a few dollars.

Sails should also be protected from sunlight as much as is practical. Ultra violet light can break down the dacron in the sail cloth and the stitching. Sails that are left furled on booms and forestays without suitable covers are most susceptible to this problem. Suitable sail covers are available through your dealer.

Mildew is no longer a major concern that it was in the days of natural fiber sails. Your new sails should be dry before folding if for no other reason than to prevent the unsightly growth of this dark mold.

In order to retain the shape of your sails they should be folded after each use. In the case of the mainsail, outhaul tension should be relieved before folding the sail on the boom.

After the season, sails should be inspected and, if necessary, serviced by a competent sail maker. For appearance's sake, stains should be removed and the sails gently washed with a mild soap and thoroughly rinsed.

#### 2.3-4 Battens

Battens are thin wooden or fiberglass stiffeners inserted in the trailing edge of your boomed sails to support the outward curved leach. When inserting the batten, the thin edge goes into the batten pocket first. Battens, particularly wooden battens, can twist and warp if they are not kept flat. Keep this in mind when storing them. Battens should always be removed when the mainsail is furled.

#### 2.3-5 Optional Sails

The first sail that you will probably want to add to your complement of working sails is a 150% genoa. This sail provides more power and speed in lighter wind conditions and is particularly effective going to windward. Intrepid Yachts has genoa and genoa gear packages available.

If you chose to add a spinnaker or other sails to your inventory, select your equipment carefully. Your dealer will assist your in selecting suitable equipment and will make you aware of the optional sails and equipment that the company has available.

### 2.4 Bilge Pump

Intrepid Yachts are equipped with a permanently installed diaphragm-type bilge pump. The pump itself is located in the cockpit area and is operated by inserting the (removable) handle into the through deck fitting. This arrangement allows the pumping of the bilge with all hatches closed; a safety precaution should you have to pump in severe conditions.

Water is carried from the bilge to the pump by a reinforced plastic hose with a strainer at the bilge end. This strainer should be checked frequently and cleaned as

needed. The pump discharges water overboard through a fitting located above the waterline near the transom.

The pump is designed to pump water containing a variety of debris, but can become clogged by excessive solid matter. If the pump should fail to prime itself after several strokes, check to see that the pick-up hose is positioned properly, then check the pump body for debris. The rubber diaphragm may be removed by loosening the screw which holds the stainless steel clamp. Inspect the pump body for foreign material and gently lift the intake and outlet flapper valves to determine that they are clear. Reassemble the pump and continue pumping.

It is wise to pump the bilge before casting off and again on returning to see if the boat is taking on unusual amounts of water.

Note: If you decide to have an electric bilge pump installed, be sure to consult an expert on the wiring and plumbing of that piece of equipment.

## 2.5 Plumbing Systems

The plumbing systems on your yacht are simple and functional. The fresh water system consists of water tank(s), hoses and foot pump(s). The scupper and drain system consists of cockpit and sink drains.

### 2.5-1 Fresh Water Tanks

The Intrepid 9 Meter is equipped with a 30 gallon water tank located under the port main cabin berth. The water fill is located amidships outboard of the hanging locker on deck.

The Intrepid 35 is equipped with two (2) 30 gallon polypropylene tanks located under the main cabin berths, port and starboard. The water fills for these tanks are deck mounted. All Intrepid installed water tanks have a vent hose that also serves as an overflow to the bilge. Water is fed from these tanks to manual pumps at the sinks through PVC hose.

If water is left standing in tanks for extended periods of time, it may adopt an unappetizing odor and appearance. If flushing the tanks does not eliminate this problem, a mild solution of baking soda may be used. After letting the baking soda stand for several hours, the tank and water system should be flushed thoroughly before refilling with fresh water.

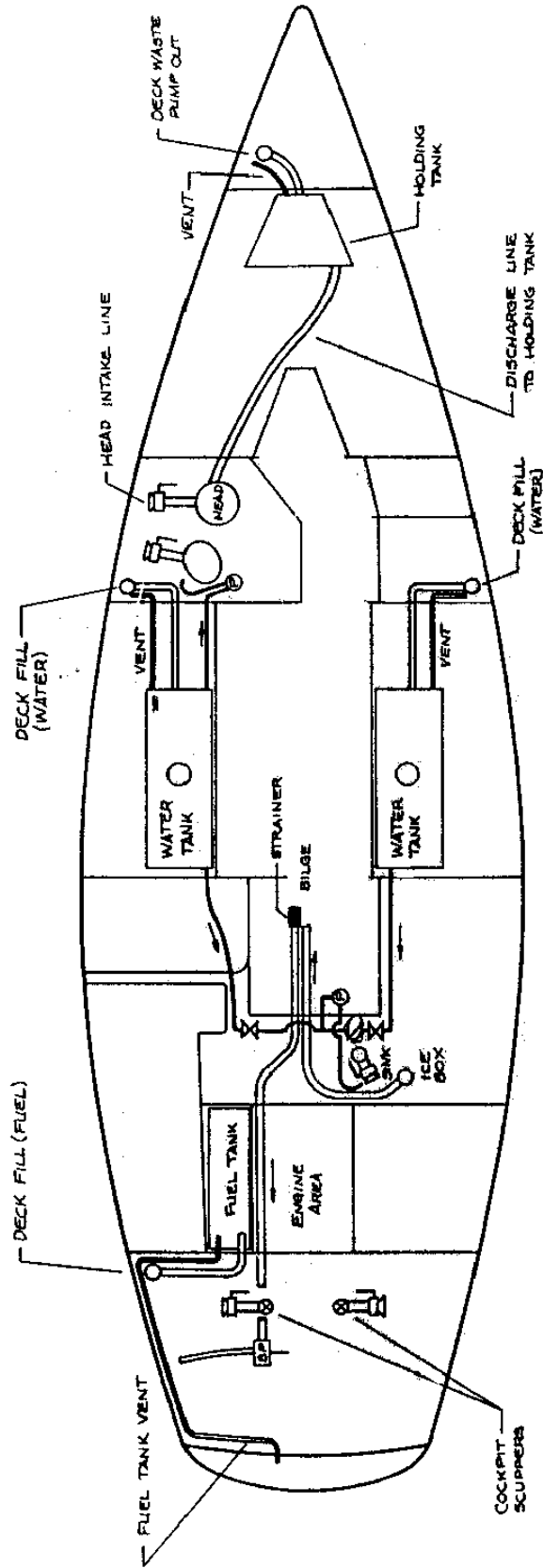

SYMBOLS

- ⌵ GATE VALVE
- ⊙ FOOT PUMP
- ⊞ SEACOCK
- BP BILGE PUMP

INTREPID 35 STANDARD PLUMBING SYSTEM

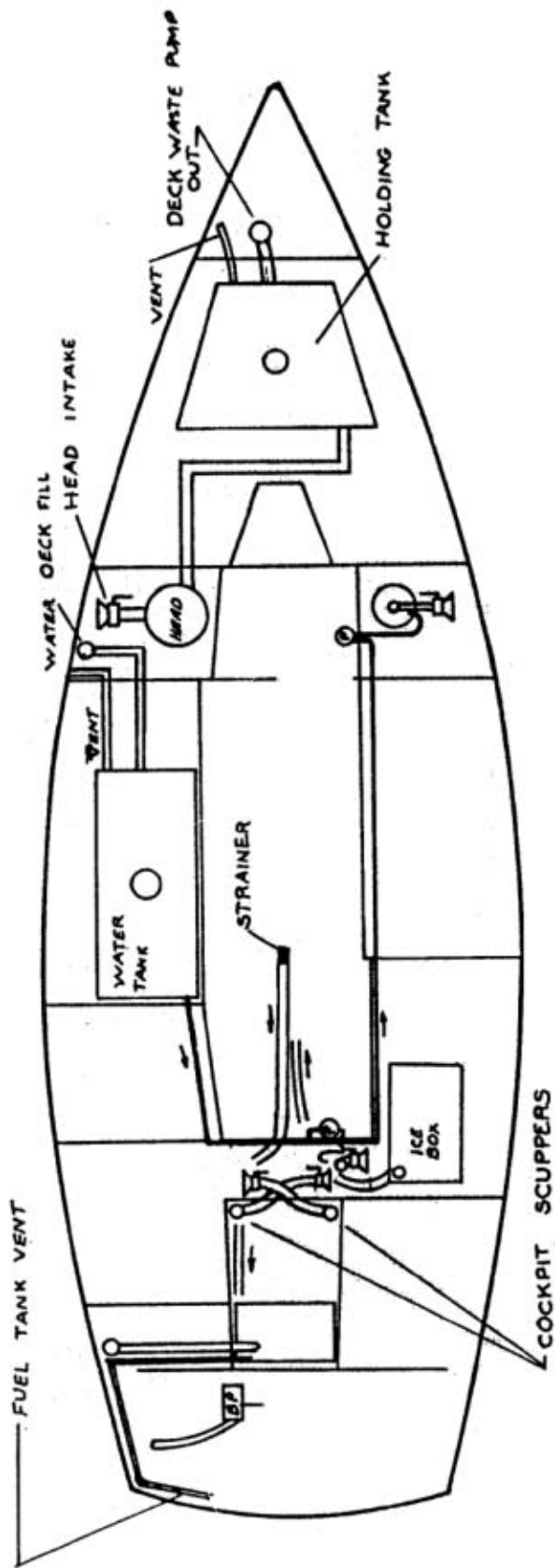

## INTREPID 9M PLUMBING SYSTEM

- ⊙ FOOT PUMP
- ⊞ GILGE PUMP
- ⊞ SEACOCK

## 2.5-2 Pumps

The foot operated fresh water pumps located in the galley and head areas are self-priming. If a pump fails to operate, check first to be certain that there is water in the tank, and then to see if the hose is kinked or being constricted by some heavy object. If the hose is clear and the pump still fails to operate, disassemble the pump and inspect the operation of the internal check valve.

## 2.5-3 Head

Both the Intrepid 9 Meter and the Intrepid 35 come standard with a marine head and a 24 gallon bow holding tank with provisions for dockside discharge. An overboard discharge capability is optional.

Included with the ship's papers are the operating and maintenance instructions for the head installed in your boat. Refer to these for any information needed.

## 2.6 Through-hulls, Valves and Seacocks

The Intrepid is equipped with bronze, flanged through-hull fittings. Valves are installed immediately adjacent to the through-hull to shut off the flow of water, should a hose fail.

Before each launching, and every time before the boat leaves its mooring or dock, you should check to see that the through-hull nuts are tight, that seacocks are working properly, and that all hose clamps are tight and in good condition. Seacocks are designed to provide a positive means of stopping the flow of water into the hull should a connection fail or a hose rupture.

These fittings are the single most important safety devices that affect the watertight integrity of your boat. Checking them for ease and effectiveness of operation means making certain that the handles move the full arc they were designed for, and that sinks, toilets and cockpits drain easily when filled.

### 2.6-1 Seacocks

Since some holes below the waterline are necessary, seacocks are designed to open and close these holes reliably. They have been in use for years aboard craft of all types, and have proven their value many times over.

The seacock is essentially a round tapered bronze shaft with a hole running along its diameter. It can be rotated from one end in a 90° arc within a pipe junction to the open or closed position. The seacock is least likely to jam open with seaweed or other foreign matter.

Routine maintenance of seacocks calls for disassembling them when the boat is out of the water, applying a waterproof grease to all friction-bearing parts and reassembling. When disassembling seacocks, do so one at a time as the

components are individually fitted to each other by their manufacturer. Your dealer or marina will suggest a good grease available in your locality.

Seacocks should be worked frequently to keep corrosion from forming, causing them to jam.

To disassemble your seacocks, follow these instructions:

There is a locknut on the outer end of the shaft – back it off and remove it. Next, back off the hexagonal end plate, removing it completely from the shaft. Then, from the opposite end, pull the shaft out of the housing. Do not use a hammer or hard object to force the shaft out of the barrel as you may damage the threads. After you have cleaned off the old grease – inside and out – and replaced with new, reverse the procedure and reassemble. Be sure that you tighten the end plate so the mechanism will not turn. A thin layer of lubricant between the end plate and locknut will facilitate tear-down next season. For obvious reasons, this procedure is to be carried out while the boat is out of the water.

The seacocks for the head, galley sink, and engine intake should normally be left in the closed position when you leave the boat. Be sure that you establish a routine of opening and closing seacocks so that you don't overheat your engine or burst hoses in the head.

Should water start to enter the boat, and for any reason a seacock is inoperable, a wooden plug (fitted for the purpose) or rags or clothing can be stuffed in the through-hull fitting to slow or stop the rush of water.

## 2.7 Steering Gear

Maintenance of the tiller steered Intrepid Yachts is simple: keep the bearing at the top of the rudder post lubricated with a good waterproof grease. Check the condition of the key and keyway on the rudder shaft and the tiller cap.

If the tiller cap is removed from the head of the rudder post, be certain to re-install the tiller cap properly. Both the rudder post and tiller cap have machined keyways in them. Be careful that the key is in the keyway and the tiller cap is installed correctly. The tiller cap should slide over the rudder shaft and key with only light pressure applied. Do not hit the cap with a hammer or other metallic object as you will dent the casting or chip off the chrome finish.

Owners of wheel steered boats should refer to the steerer manufacturers maintenance and usage information shipped with the boat.



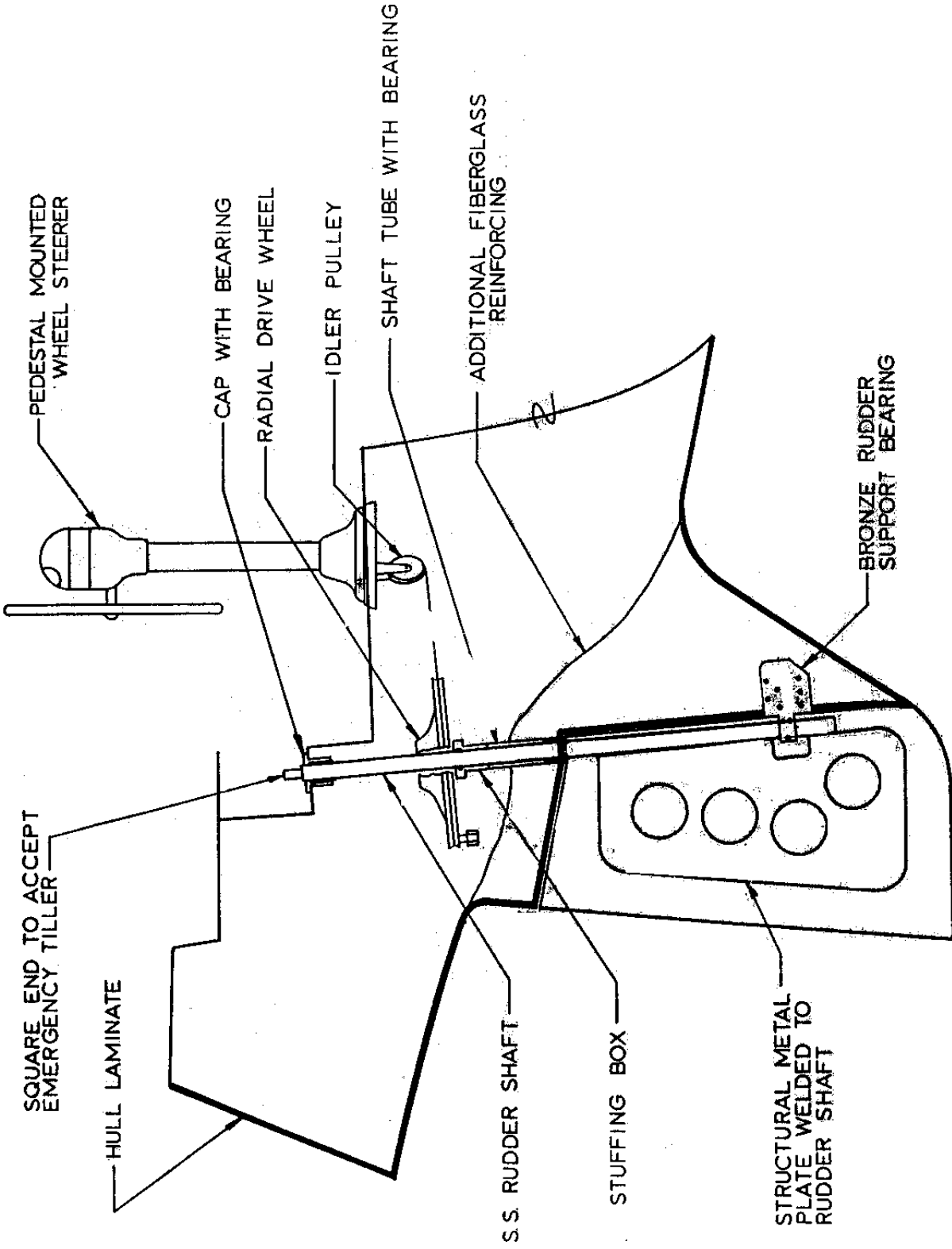

I35 RUDDER SHAFT DETAIL

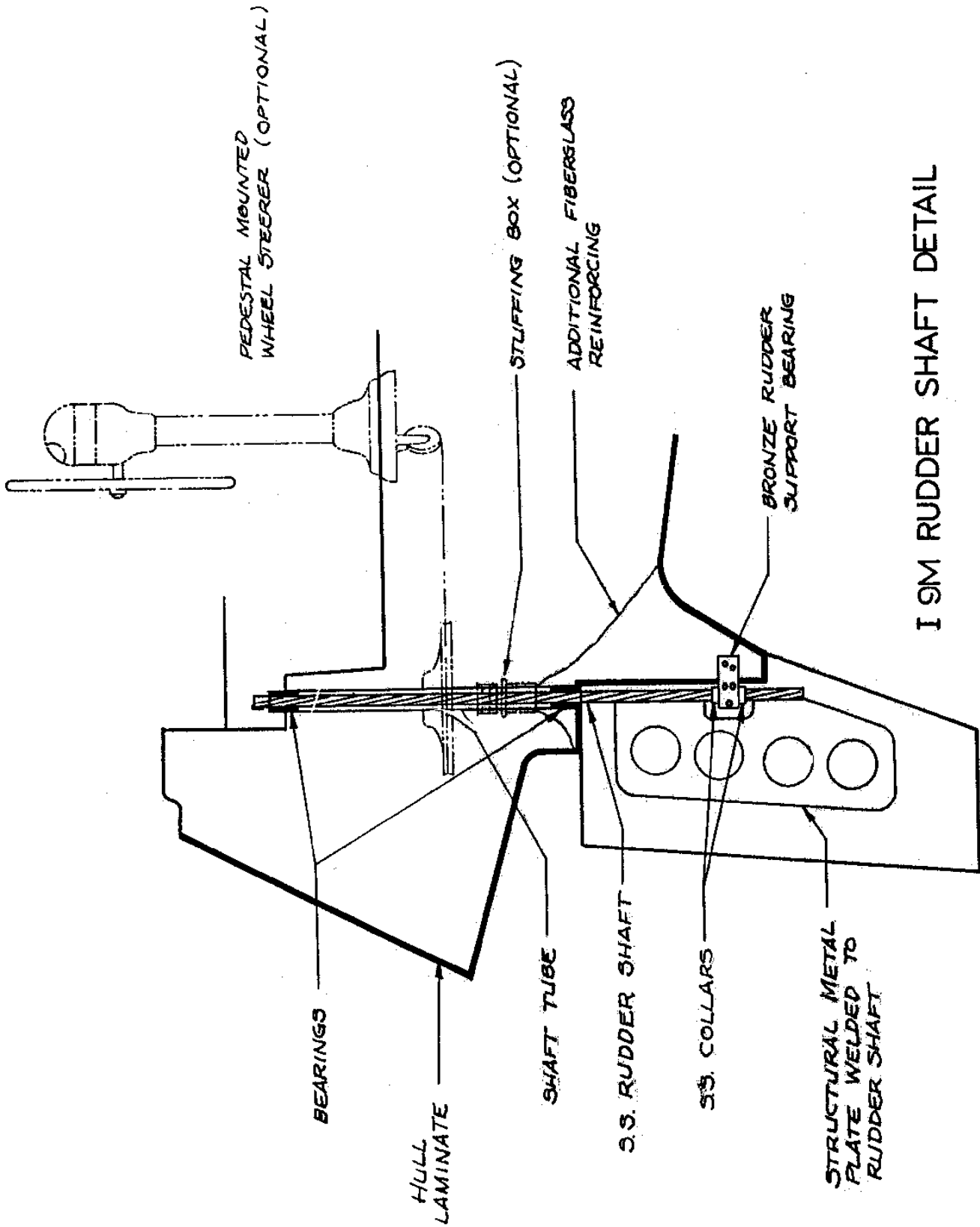

1.9M RUDDER SHAFT DETAIL

## 2.8 Electrical System

### 2.8-1 Battery

The Intrepid 9 Meter is equipped with a 65 amp-hour 12 volt marine type battery located in the engine compartment. The Intrepid 35 is equipped with two (2) 65 amp-hour 12 volt marine batteries located in the engine compartment. Each battery is enclosed in a break resistant non-conductive case. All Intrepid Yachts shipped with batteries are negative ground.

Batteries are relatively maintenance free. If you keep the battery and terminals clean and free from corrosion and if you keep the electrolyte at the proper level, they should give you trouble free service.

*Caution:* Avoid spilling battery electrolyte into the bilge and avoid getting any salt water in the battery. If this should occur, ventilate extremely well since poisonous gas will be given off.

### 2.8-2 Battery Switch

Since many skippers of cruising auxiliaries prefer a two battery system, Intrepid Yachts are equipped with a battery switch that will accommodate dual batteries.

This spare battery is commonly reserved for engine starting duty. Once the engine is started, the alternator is allowed to fully charge the starting battery, then the switch is thrown to the other battery for charging. **NEVER TURN THE BATTERY SWITCH TO THE OFF POSITION WHILE THE ENGINE IS RUNNING.** This can seriously damage the alternator or regulator.

### 2.8-3 Instrument Panel

Every Intrepid Yacht is equipped with an electrical distribution panel. Every toggle switch has a circuit breaker with its amperage rating labeled next to the breaker. Should a circuit breaker trip, you will be able to tell by seeing the breaker protruding out from the panel and showing a red band around its base. To reset the breaker, turn the circuit off with the toggle switch and push the circuit breaker back into the panel. The plastic central portion should stay in the breaker and the red band should not be visible.

Every panel is equipped with a sensitive volt meter to monitor the battery condition. It is activated by a toggle switch immediately adjacent to the meter. The scale on the meter is clearly marked and should aid you in not running your battery down to a level where you can't start your engine.

# INTREPID 9M ELECTRICAL SYSTEM

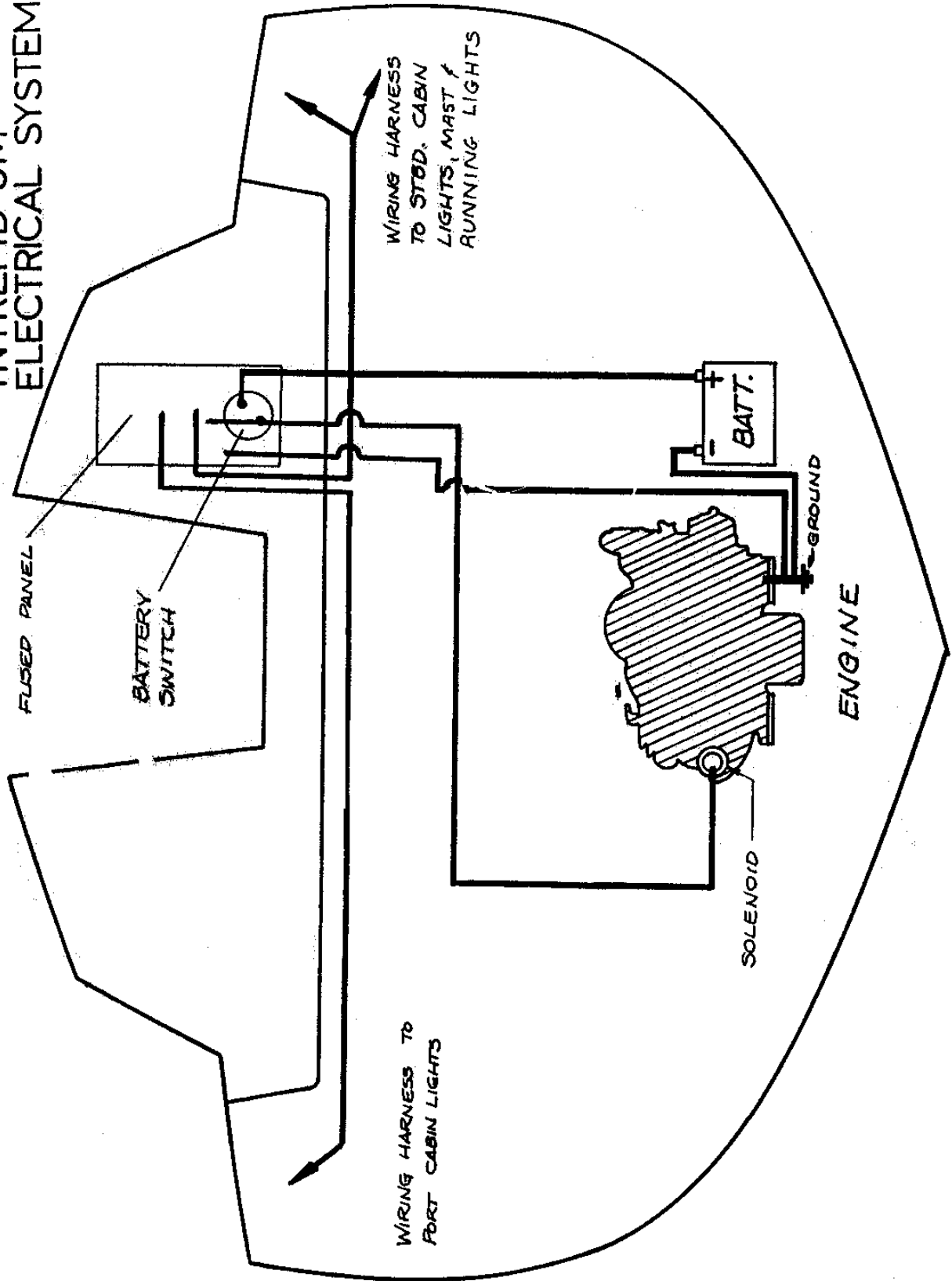

# INTREPID 35 ELECTRICAL SYSTEM

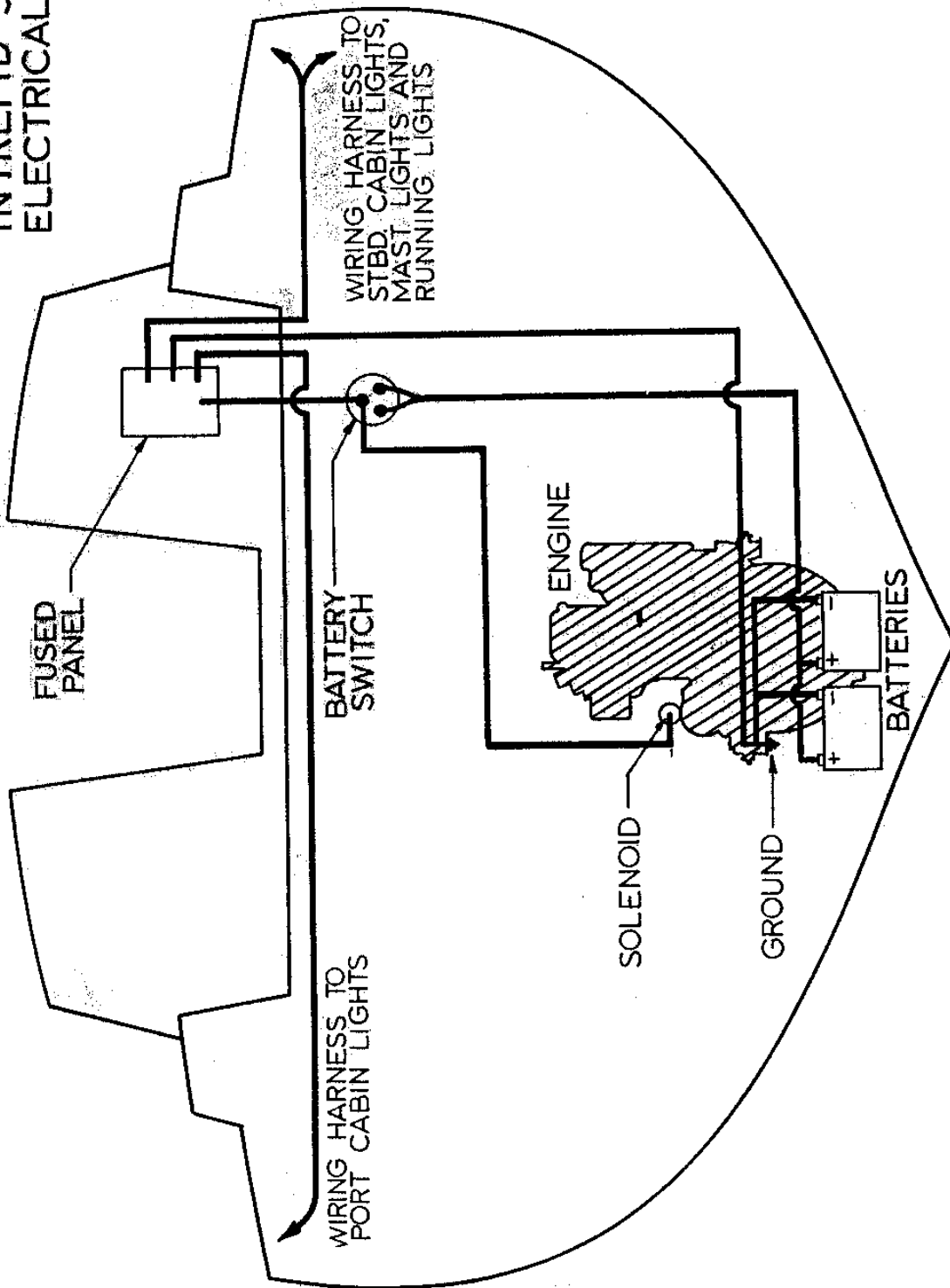

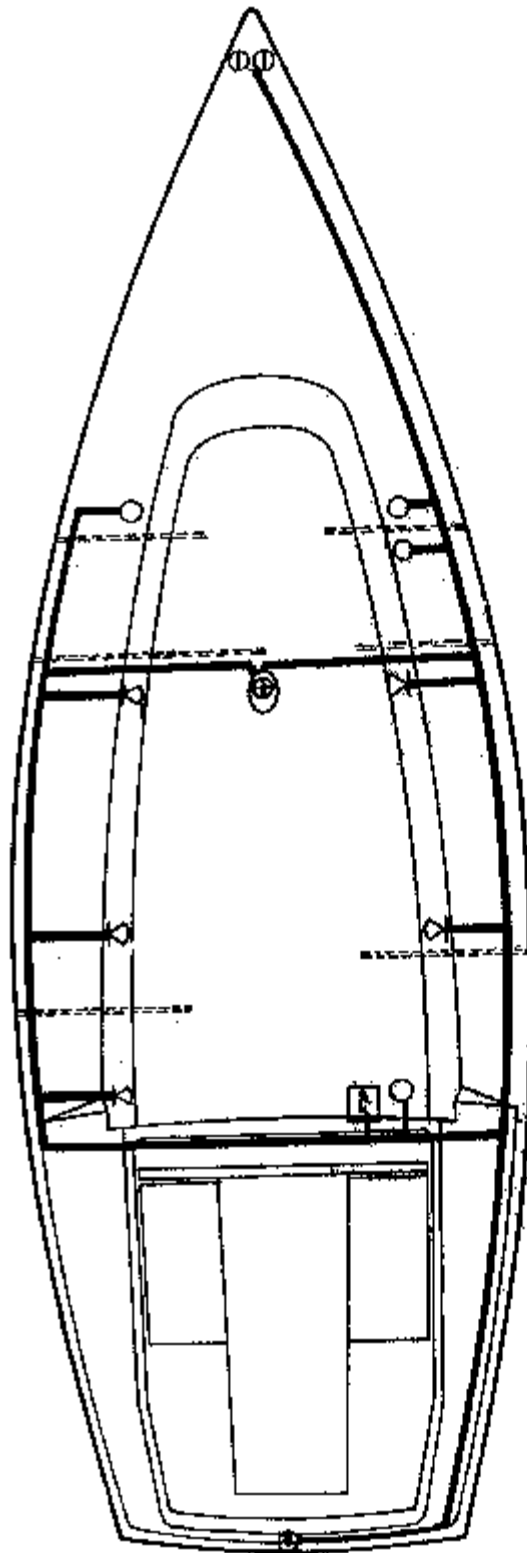

# I9M WIRING SYSTEM

## KEY

- ⊕ MAST LIGHT
- ⊙ BOW LIGHT
- ⊖ DOME CABIN LIGHT
- ⊘ STERN LIGHT
- △ SWIVEL MTD CABIN LIGHT
- FP FUSE PANEL
- ▬ WIRING HARNESS

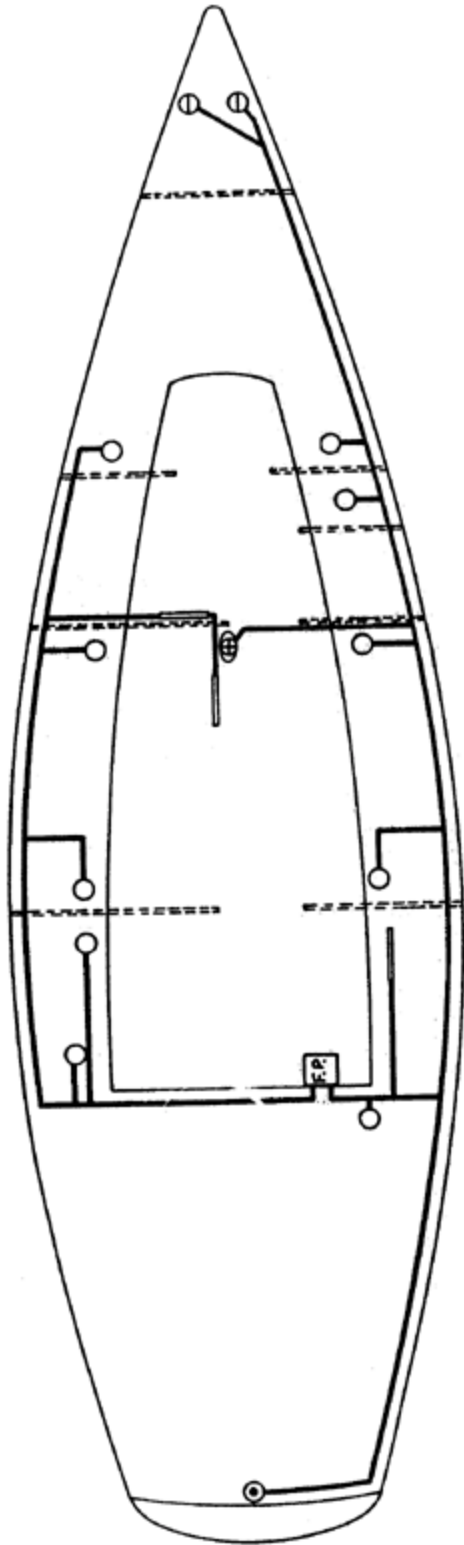

INTREPID 35 WIRING DIAGRAM

- KEY
- F.P. FUSED PANEL
  - ⊗ MAST LIGHTS
  - ⊙ DOME CABIN LIGHT
  - FLUORESCENT LIGHT
  - ⊖ BOW LIGHT
  - ⊘ STERN LIGHT
  - WIRING HARNESS

A red pilot light is wired directly to the battery switch. This light is always on any time the battery switch is not in the off position. This light provides you several services, among which is that it will make it easier for you to tell if you turned your battery switch off before you leave the boat and also provides illumination for reading the labels of the various circuits at night. The pilot light has an almost immeasurable drain on the battery so you needn't fear leaving its light glowing for long periods of time.

The panels are attached to the wiring harness by a multi-prong plug. Should you want to remove the panel you merely remove the screws holding it to the bulkhead, disconnect the battery wires, common, and ground (these are attached with threaded connections), and disconnect the multi-pronged connector.

Activate only those circuits required in order to conserve the battery charge. Switch all circuits to the off position when leaving the boat unless you have an electric bilge pump which you wish to leave on.

Wiring for lighting circuits is twisted AWG #16 with insulation. Engine starter motor wiring and ground wire is AWG #3 for the ground and #4 for positive. The lightning ground is AWG #8 wire.

Check engine wiring connections frequently and clean and tighten them if necessary.

#### 2.8-4 Lightning Ground

The Intrepid is equipped with a lightning ground system which connects the shroud and stay chainplates to an underwater metal plate mounted on the hull using AWG #8 wire. Since no one can predict where or how powerfully lightning may strike, exercise caution. During a lightning storm refrain from touching large metal objects such as shrouds, mast, stanchions, pulpit, etc. as these may attract lightning.

### 2.9 Engine and Propulsion System

You have been provided with an instructional manual for the engine in your Intrepid Yacht. We have just a few suggestions which will probably repeat what the owner's manual says regarding your diesel inboard:

1. Familiarize yourself thoroughly with the starting, running and stopping procedure before you leave the dock.
2. Be sure you are using clean, water-free fuel and that the filters are kept clean.
3. Diesel fuel is flammable. Treat it with respect.
4. Make sure that you do not put gasoline in your fuel tank in error. Marine, water-free diesel fuel oil is the only acceptable fuel.



5. Be sure you put fuel in the fuel tank and water in the water tank.
6. Be sure that cooling water is coming out of the transom exhaust port, that the cooling water seacock is open and that the screen is free of growth and debris.
7. Carefully follow the recommended winterization procedure included in the engine manufacturer's bulletin.
8. See section 3.3 for recommended fueling practice.
9. Read the engine owner's manual carefully.

#### 2.9-1 Propeller Shaft Alignment

Propeller shaft alignment is extremely important to the performance of your diesel auxiliary. Every Intrepid Yacht has its engine aligned on the bed before it leaves the factory. The engine may shift on its bed, however, during transport or launching. As part of the commissioning procedure, your dealer must recheck this alignment after the boat has been launched and prior to starting the engine. Alignment must also be checked and adjusted every year or whenever vibration seems to be a problem. Proper alignment will not eliminate all vibration but it is an important factor in reducing it.

Place the propeller shaft flange and the reverse gear flange together so that the guide locates properly. With the flanges pressed against each other, check the parallelism with a .002" feeler gauge. The gauge must not enter between the flanges at any point. Turn the flanges through 360 checking constantly with the feeler gauge. Be certain that the flanges are pressed firmly against each other throughout the whole procedure. If there is a gap of more than .002" between the flanges at any point, the engine must be repositioned on the mounts.

Care must be taken when reassembling the coupling to see that the key is properly inserted and that the set screws are wired in place.

#### 2.10 Interior Maintenance

Periodic cleaning is essential to keep the interior of your boat clean and bright. Choose sunny, breezy days for your boatkeeping chores as sun and fresh air are great help in drying and airing the interior cushions, etc. while you continue with chores below.

I 9M VOLVO MD 7A  
TOP VIEW

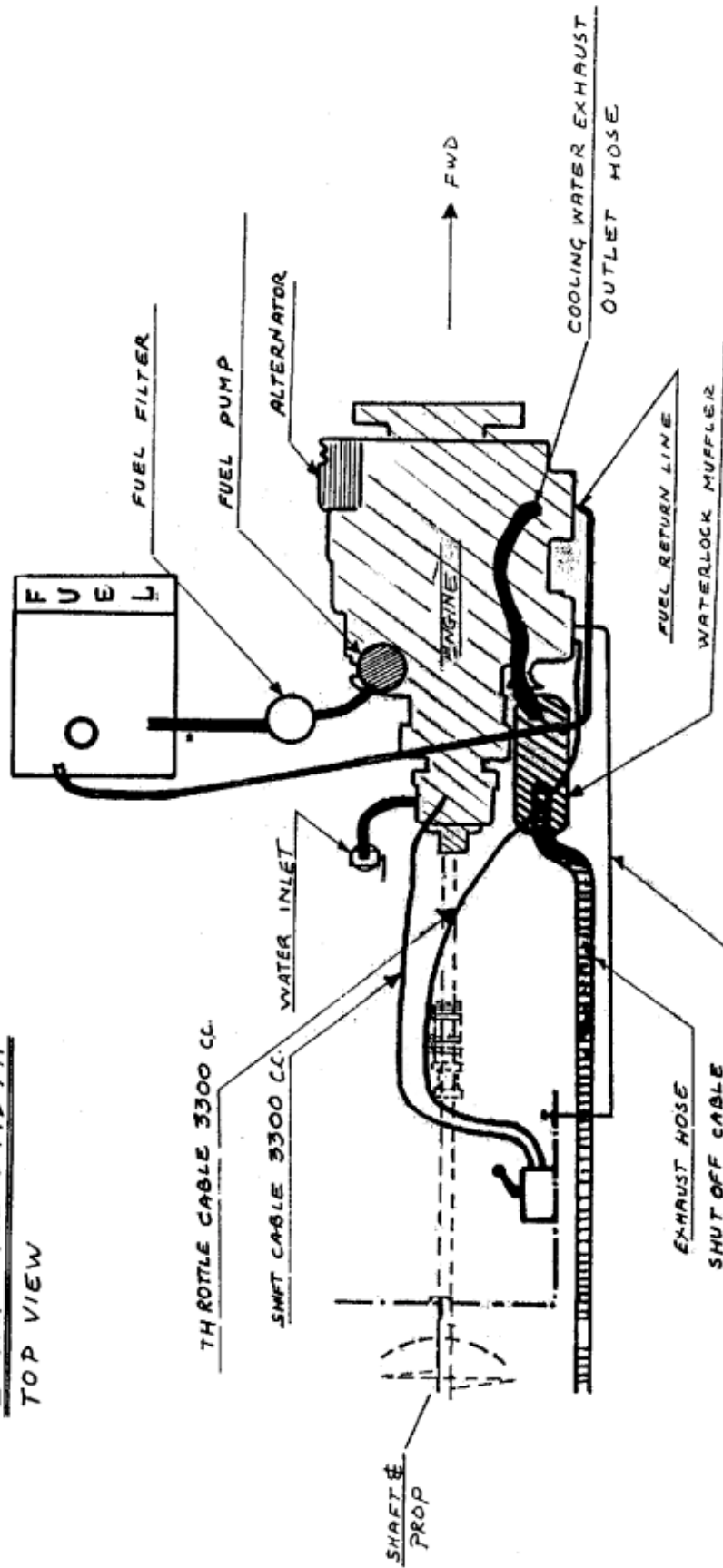

INTREPID 35 ENGINE AREA DETAIL

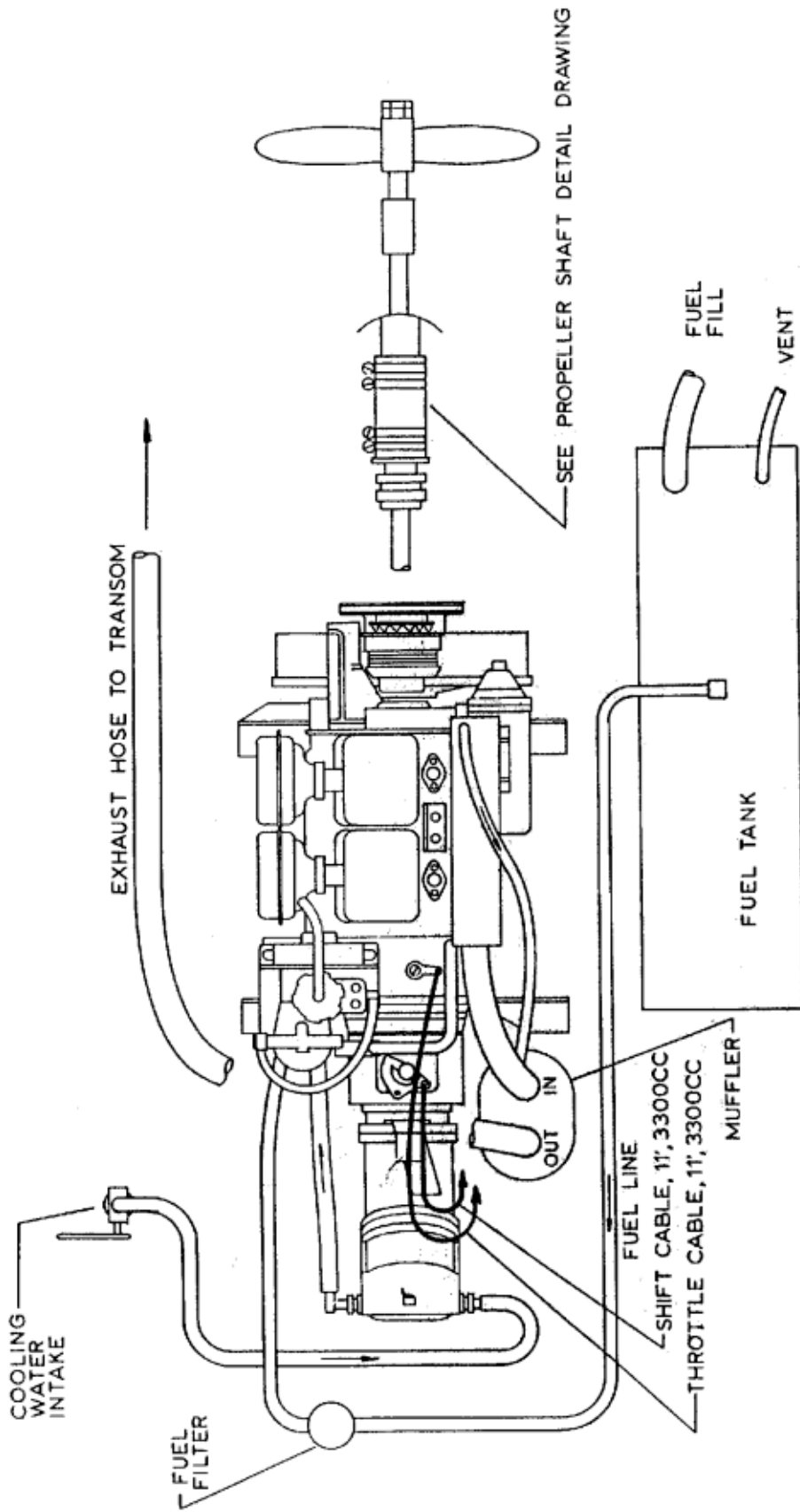

# INTREPID MOTORMOUNT

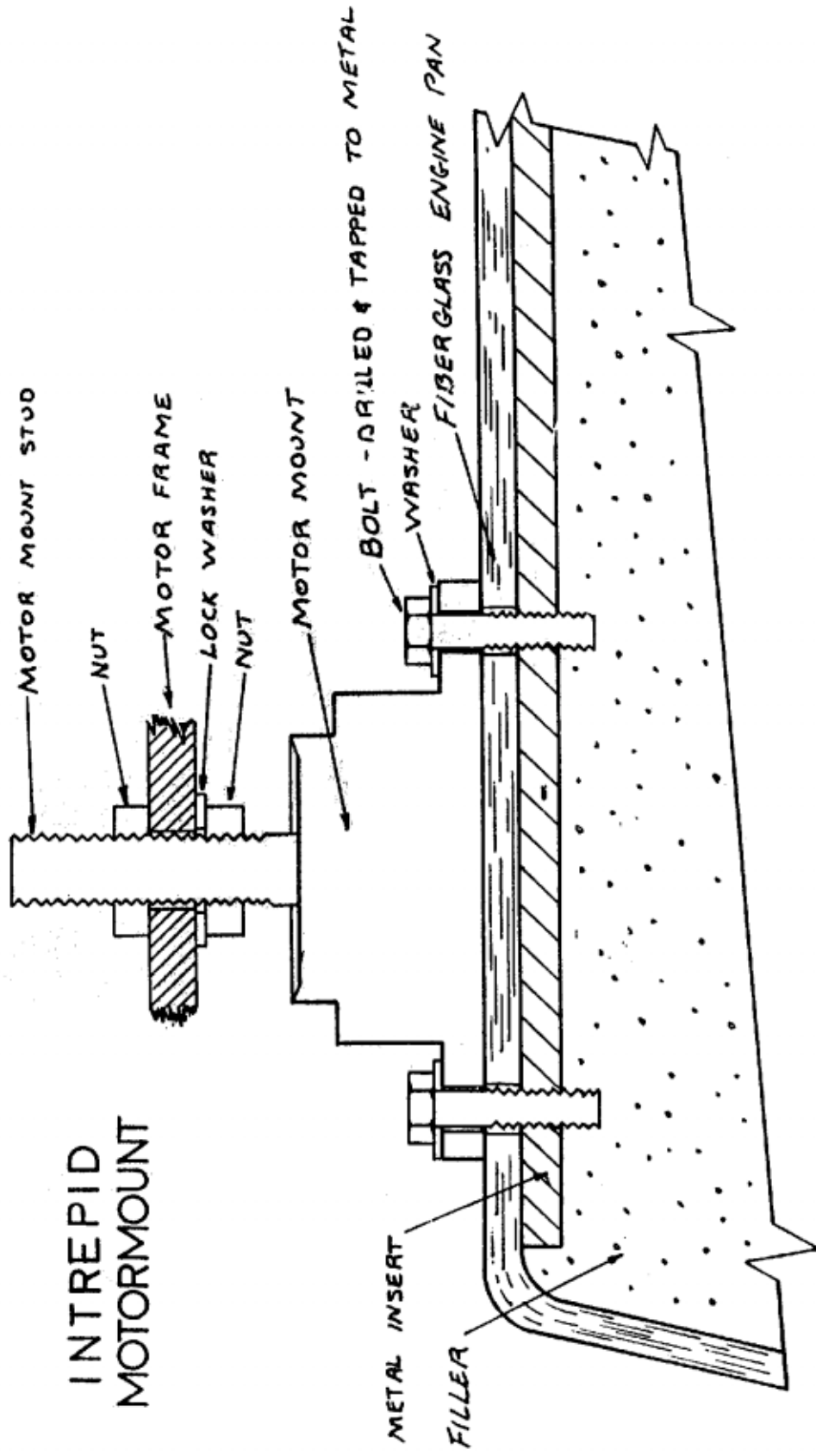

PROPELLER SHAFT DETAIL

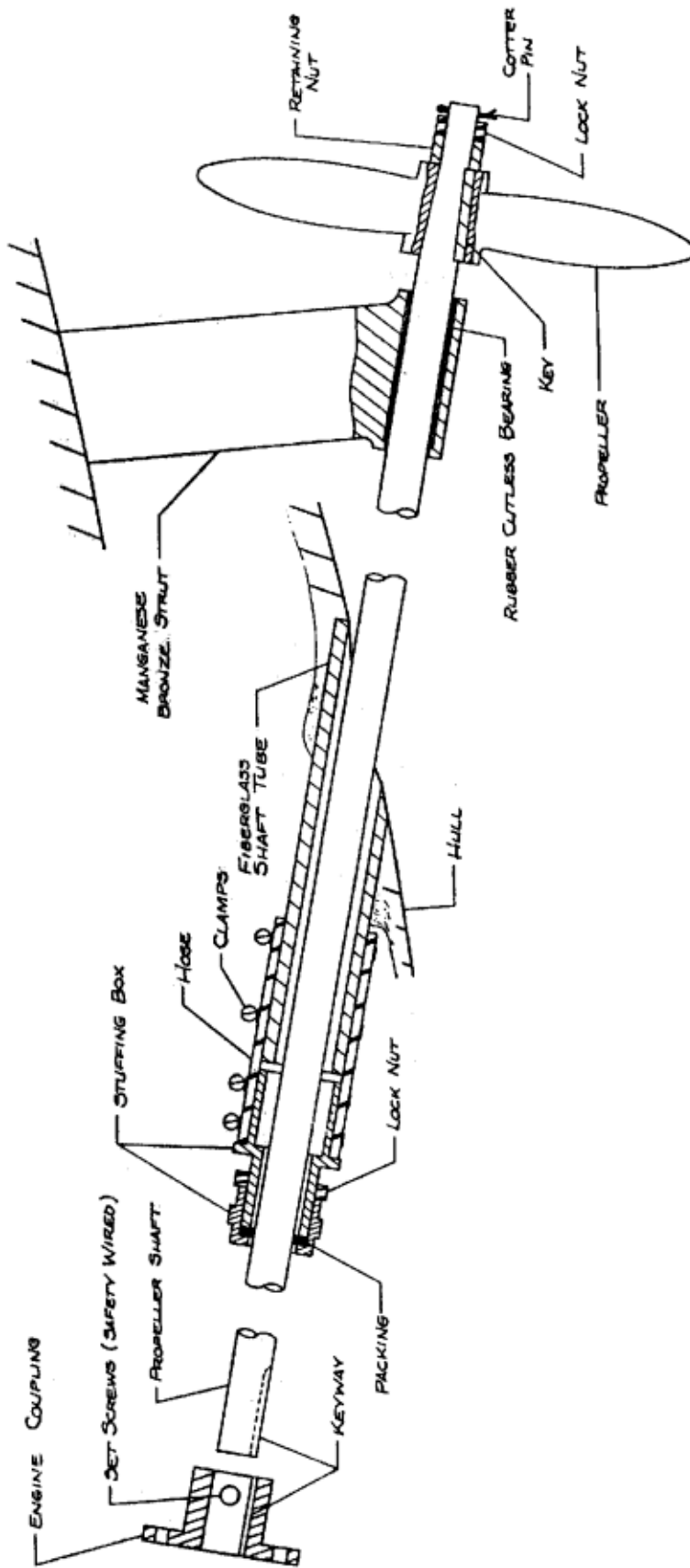

### 2.10-1 Cushions

Cloth covered interior cushions on the Intrepid are made of nylon fabric. These cushions may be kept clean by washing with a 50/50 solution of Lestoil and water. Sponge this solution into the cushions as you would shampoo upholstered furniture. Rinse with clear water in a similar fashion and blot excess moisture remaining with a clean cloth or towel. Cushions must be dried thoroughly after cleaning. Do this type of cleaning on warm, sunny days when cushions may be thoroughly dried outside in the sun.

### 2.10-2 Ice Box

The ice box on your Intrepid is designed to drain water from melted ice through scuppers into the bilge. Because small food particles, juices from meats, etc. may also drain into the bilge, it is wise to use a name brand bilge cleaner in the bilge as needed or every three to four weeks (depending on how frequently you are using the ice box). Follow the directions for use which accompany the cleaner which you select.

Another alternative is to fit a plastic gallon jug on the end of the ice box drain hose. Periodically dump the melted ice out into the sink.

Food items should not be left for long periods of time in a closed ice box without ice. Spoilage, odors, mold and mildew will result. Plan to clean out your ice box (both ice and food items) at the end of each sail or cruise when you are leaving the boat for an extended period of time. Remove the ice box cover to permit thorough drying. Clean up any spillage of food in the ice box, etc. to prevent blocking of the scuppers and the drainage of this material into the bilge.

Clean the fiberglass interior of your ice box periodically with a sponge dampened with water and bleach solution (this will help to prevent mildew and odors in the ice box).

### 2.10-3 Ports

Ports may be cleaned with any household window cleaner and a soft cloth. Do not use strong solvents on Plexiglas ports.

### 2.10-4 Stainless Steel Sinks

Stainless steel sinks may be cleaned with any stainless steel cleaner according to the manufacturer's instructions or with a non-abrasive cleaner or soft cloth and sponge.

### 2.10-5 Head

The plastic seat and vitreous china bowl of your head should be cleaned with a non-abrasive cleanser and sponge or soft cloth.

#### 2.10-6 Interior Wood Surfaces

Interior wood trim and paneling should be oiled periodically to maintain its beautiful new appearance. Use a good quality teak oil.

#### 2.10-7 General

Dirt, hair, etc. should not be washed into the bilge during any cleaning process as these may plug the bilge pump strainer and prevent it from functioning when needed. Use a dust pan to collect dirt, etc. when cleaning the cabin sole of your boat.

Raise covers of lockers when leaving the boat to permit adequate ventilation and prevent mildew should these contain moisture. There are scuppers in all lockers for drainage of moisture. Be certain that these are not clogged and remove excess moisture which may be collected in lockers with a sponge.

#### 2.10-8 Stoves

The Intrepid comes equipped with a galley stove as standard equipment. The manufacturer of the stove includes owner's manuals with the appliance. Read it carefully and make sure that everyone who uses the stove understands its operation. Remember alcohol fires can be extinguished with water or Type B fire extinguishers.

The following precautions refer to all types of stoves. Refer to owner's manual for specific instructions.

1. Never leave lighted stove unattended.
2. Never leave a stove when it is still hot. Remember alcohol can burn with an almost invisible flame.
3. Always release pressure in the fuel tank when leaving.
4. Close fuel valve (if applicable) in case of emergency.
5. Exercise caution when priming burners. Improper priming is one of the most common causes of galley fires.

#### 2.11 Maintaining Teak

Teak above deck on the Intrepid has been sanded and oiled to a full golden hue before it leaves the assembly area. As it gets exposed to sunlight and drying conditions, the wood begins to take on a grey appearance that will eventually lead to surface deterioration of the wood. Teak which is ignored will eventually begin to split and the grain will lift.

Contrary to what you may have heard, teak is not a miracle wood that is totally maintenance free. It is easy to maintain. There are a number of excellent teak cleaning and sealing preparations on the market. We suggest that you ask your sailing friends (who have teak you admire) for their suggestions. (Many excellent teak cleaning and sealing products are not available nationwide, so use the best available in your area.)

The teak may also be varnished; put three to six coats on initially. Plan to apply another coat at midseason, and the final coat prior to winter layup. Follow the manufacturer's directions for the varnish which you purchase (use only quality marine varnish).

### 3.0 SAFETY AND EQUIPMENT

Federal regulations require certain safety equipment to be aboard your boat (personal) and throwable flotation devices, fire extinguishers, horn, whistle, etc.). Know what equipment is required and have it aboard and properly stowed before you cast off for the first time.

In addition to the equipment requirements outlined here, the U.S. Coast Guard can provide additional information and answer your questions. It is highly recommended that, although not required, certain additional items be kept aboard:

1. An anchor of appropriate size and design and rode of good quality, appropriate size and length
2. First-aid kit
3. Compass
4. Paddle
5. Flashlight
6. Up-to-date charts of the waters to be sailed

#### 3.1 Fire Extinguishers

Fire extinguishers are not standard equipment on your Intrepid; they are to be provided by you, the owner. Fire aboard any boat is a real and serious hazard. It is important to take adequate precautions against fire and be well prepared to extinguish one quickly and thoroughly should it occur. For this reason, U.S. Coast Guard approved fire extinguishers of the appropriate type and size (check U.S.C.G. regulations) should be installed immediately.

The permanent location of fire extinguishers where they are easily accessible (near areas where fires are most likely to occur – engine, fuel tanks, and galley) is important. They should not be located where fire may prevent their use. At least one extinguisher in a cockpit locker (reachable from outside the cabin) is an excellent precaution.

#### 3.2 Fueling



Appropriate safety precautions are important before, during, and after fueling. Before fueling the first time, be familiar with the instructions provided by the engine manufacturer.

1. Fuel docks should be approached at reasonable speed without wake. Observe posted speed limits and instructions. Be considerate of others using the docks, and watch for a dockmaster or hand who might give you instructions. Maintain control of your boat at all times and have dock lines ready for use before your approach in the event that these are unavailable at the dock.
2. Use bow, stern and spring lines to properly secure your boat.
3. Close and secure all hatches and ports.
4. **FORBID SMOKING** while taking on fuel on or near fuel docks. Completely extinguish all smoking materials well in advance of approaching the docks; do not recommence until you are well clear of it after fueling and conditions aboard are safe to do so.
5. Extinguish any other open flames aboard and see that all equipment (e.g., engine, stove, cabin heater, radios, and lights – both lanterns and electrical lights, etc.) which may generate heat or sparks of any kind are turned **OFF**... Turn off all switches for branch circuits so that there are no live electrical circuits. Main switch should also be turned off **AFTER** engine is stopped (to prevent alternator damage).
6. If possible, crew members not involved in fueling should leave the boat.
7. An adequate fire extinguisher (U.S.C.G. approved for Class B fires) should be readily available in case of emergency.
8. Remove fill fitting. Be certain that you are putting fuel into the fuel tank. Note the approximate amount required to fill the tank by either looking at the level gauge or use a clean stick to determine the level of fuel in the tank.
9. Be certain (double check) that you are taking on the appropriate fuel. Errors of this type do occur and will result in serious engine damage if not immediately detected and corrected.
10. Maintain contact between the nozzle of the fuel hose and the fill pipe rim to prevent generation of static electricity sparks.
11. Fill slowly to about 85% of capacity. Do not overfill (allowance must be made for thermal expansion of fuel without overflow).
12. Replace and secure fill fitting after fueling. Carefully clean any spillage. Check fuel tank vents at stern for overflow. Check below decks and in bilge for fumes or leakage. If fumes or leakage are present, adequately ventilate and clean areas completely before proceeding.

13. Open all ports and hatches fully for ventilation.
14. Do not fuel during electrical storms. Avoid fueling at night or in rough water, except in emergencies when extreme caution should be exercised.
15. Note that diesel fuel is flammable. Handle it accordingly in a cautious manner.

### 3.3 Weather Forecasts

The U.S. Coast Guard is in the process of discontinuing the display of weather signals at its stations and other locations along all coasts in favor of the NOAA weather broadcasts which are continuously broadcast on weather channels WX-1 and WX-2 (162.40 MHz and 162.55 MHz).

Good seamanship requires attention to the weather forecast before leaving port, and while you are sailing. Tune in to VHF weather, and make it a practice to check the broadcast on a regular basis in case there are changes in the forecast. (Radio not supplied as standard equipment.)

### 3.4 Boating Safety Organizations

Every sailor was once a beginner. Very few were born into sailing families and learned at their parents' knees. Therefore, it is to everyone's benefit that there are several fine non-profit organizations that are ready to teach interested persons everything from basic seamanship and piloting to celestial navigation.

Two of these organizations are:

United States Power Squadron (U.S.P.S.)  
United States Coast Guard Auxiliary

### 3.5 Charts

There is not substitute for complete and up-to-date charts.

The Coast Guard is constantly making improvements on the aids to navigation which change buoy locations, numbers, configurations, etc. These changes are reported in the responsible Coast Guard District's Local Notice to Mariners, and are on display at all NOAA Chart Distributors. Before embarking on any trip outside your home port, make certain that you have the latest editions of the chart, and that they are fully corrected.

## 4.0 WINTERIZING

Winterizing is a relatively simple procedure on the Intrepid. We are assuming that the boat will be dry stored in the following instructions. If you should decide to wet store your boat, be sure to take adequate precautions against water freezing in the engine and plumbing systems on your boat.

#### 4.1 Blocking the Hull

A good boatyard is, no doubt, expert at properly supporting the hull. Check to make sure that the weight of the hull is resting on the keel. The purpose of cradle bulkheads is to balance the boat in an upright position, not to bear the weight of the boat.

Before hoisting out, show the boatyard the profile of the hull so that they will know how to position crane or straddle hoist straps.

#### 4.2 Ice Box

Clean ice box thoroughly and leave open.

#### 4.3 Stove

Clean stove thoroughly including burners. Release pressure in fuel tank and leave tank empty.

#### 4.4 Electrical System

Remove battery(s) from boat and store in a warm dry location off a cement or stone floor. They should be completely charged before storing or left on trickle charge.

The balance of the electrical system requires little maintenance. If you wish, each bulb can be removed and the light fixture given a spray of water dispersant such as “WD40”, “CRC” or similar products. The main switch and fuse panel can also be treated this way to minimize corrosion.

#### 4.5 Propeller and Shaft

Examine the propeller for any damage or nicks. If evidence of either is apparent have the propeller removed and trued.

The shaft coupling should be separated from the engine and stored in this manner. This eliminates any possible strain being placed on the shaft should the hull shape alter while in the cradle. It also reminds you to re-align the shaft every spring.

#### 4.6 Head

Follow manufacturer’s directions closely. Remove any water to prevent from freezing.

#### 4.7 Water Tanks

Pump tank(s) as dry as possible, then add a non-toxic water system winterizer that your local marine hardware store will recommend. (Caution: Do not use anti-freeze or other poisonous substances). Pump this solution through the entire fresh water and drain system.

#### 4.8 Engine

Follow the instructions in the engine owner's manual supplied by the manufacturer.

Disconnect engine cooling water intake to make sure that no water remains in the line. Reconnect line and secure hose clamps.

#### 4.9 Fuel Tanks

The best way to store a fuel tank is empty. Partially filled tanks invite condensation. Completely filled tanks leave you with old fuel in the spring with its possible gum deposits. Much has been written lately on this subject and new products are being developed to prevent gum deposits. Keep informed and consult your dealer or shipyard for recommendations.

#### 4.10 Covering

It is far better to store a boat under cover than to leave it open to the elements. The teak trim will fare better during the winter and the boat will not be subjected to the pressure of freezing water, a common cause of gel coat stress cracks. If your boat cover is durable, open a couple of ports to allow air to circulate below decks.