

CHAPTER 1  
**GENERAL**

1. Exterior Views .....	1-1
2. Specifications .....	1-2
3. Principal Construction .....	1-3
4. Performance Curves .....	1-4
5. Features .....	1-6
6. Engine Cross-Section .....	1-7
7. Exterior Views .....	1-8
8. System Diagrams .....	1-12
9. Accessories .....	1-19

# 1. Exterior Views

## 1-1 Starboard

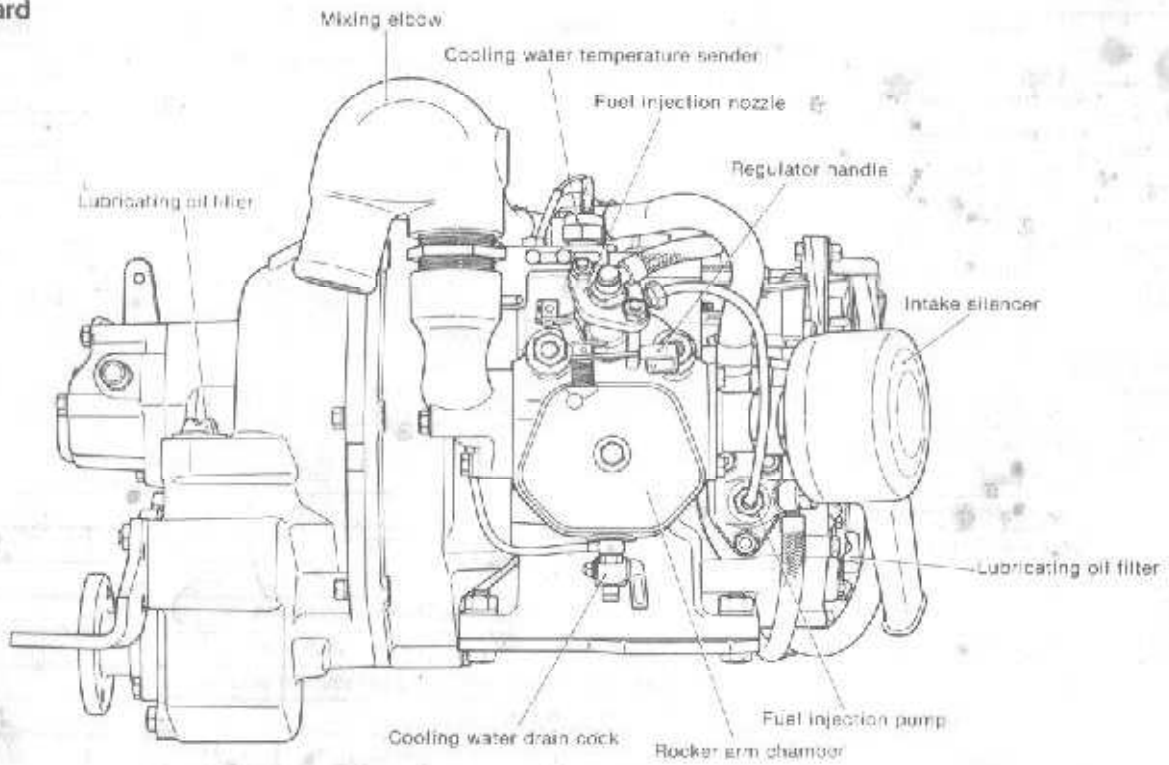

## 1-2 Port

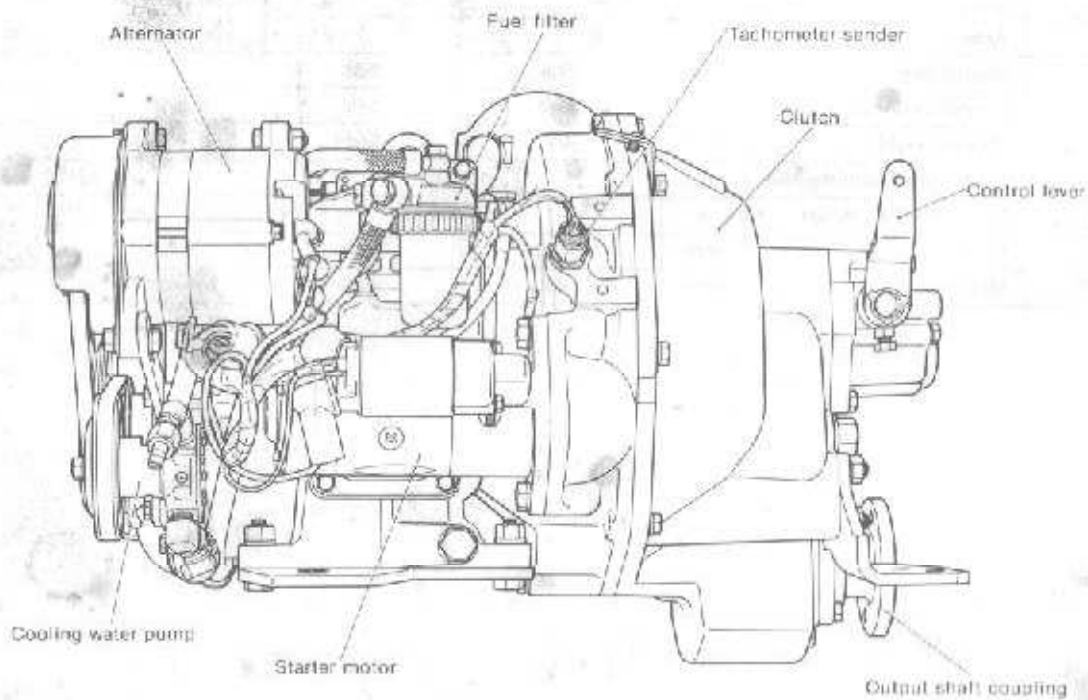

## 2. Specifications

Model			YSM8-R		YSM8-Y		YSM12-R		YSM12-Y	
Type			Horizontal 4-cycle water-cooled diesel engine							
Combustion chamber			Precombustion type							
Number of cylinders			4							
Bore × stroke		mm	75 × 75				85 × 90			
Displacement		l	0.331				0.510			
Continuous rated output (DIN 6270A)	Output/crankshaft speed	HP/rpm	7/3200				10/3000			
	Mean piston speed	m/s	8.0				9.0			
	Propeller speed	rpm	1639	1093	1639	1093	1518	980	1518	980
One hour rating (DIN 6270B)	Output/crankshaft speed	HP/rpm	8/3200				12/3000			
	Mean piston speed	m/s	8.0				9.0			
	Propeller speed	rpm	1639	1093	1639	1093	1518	980	1518	980
Compression ratio			23:1				21:1			
Fuel injection timing		deg	bTDC 25							
Fuel injection pressure		kg/cm <sup>2</sup>	160 ± 10							
Engine weight (dry)		kg	102		92		130		120	
Power takeoff position			Flywheel side							
Direction of rotation	Crankshaft		Counterclockwise (viewed from clutch side)							
	Propeller shaft		Counterclockwise (viewed from clutch side)							
Cooling system			Sea water forced cooling (rubber impeller water pump)							
Lubrication system			Closed forced lubrication							
Starting system			Electric with manual		Manual		Electric with manual		Manual	
Reduction gear system			Spur gear constant-mesh system							
Clutch			Wet single-disc mechanical type							
Reduction ratio	Ahead		1.95	2.93	1.95	2.93	1.98	3.06	1.98	3.06
	Astern		1.95	2.93	1.95	2.93	1.98	3.06	1.98	3.06
Engine size	Overall length	mm	606		598		638		628	
	Overall width	mm	602		576		673		647	
	Overall height	mm	436		544		485		591	
Lubricating oil capacity (rake angle 8°)	Crankcase Total/Effective	l	1.9/0.8				3.0/1.0			
	Clutch Total/Effective	l	0.7/0.2				0.7/0.2			
No-load engine speed	Maximum	rpm	3400		3400		3150		3150	
	Minimum	rpm	650		600		650		600	

## 3. Principal Construction

Group	Part	Construction
Engine block	Cylinder block	Integrally-cast water jacket and crankcase
	Cylinder liner	Wet type coated with anticorrosion paint
	Main bearing	Metal housing type
Intake and exhaust systems and valve mechanism	Cylinder head	Gasket separate valve guide
	Intake and exhaust valves	Poppet type, seat angle 90°
	Intake pipe	Intake inertia type steel pipe
	Exhaust silencer	Water-cooled mixing elbow type (optional)
	Valve mechanism	Overhead valve push rod, rocker arm system
	Intake silencer	Round polyurethane sound absorbing type
Main moving elements	Crankshaft	Stamped forging
	Flywheel	Attached to crankshaft by tapered
	Piston	Oval type
	Piston pin	Floating type
	Piston rings	3 compression rings, 1 oil ring
Lubrication system	Oil pump	Trochoid pump
	Oil filter	Full-flow type, steel plate element
	Oil level gauge	Dipstick
Cooling system	Water pump	Rubber impeller type
	Thermostat	Wax pellet type
Bilge system	Bilge pump	Rubber impeller (tandem type) combined with C.W. pump (optional)
Fuel system	Fuel injection pump	Bosch PFR type
	Fuel injection valve	Semi-throttle valve
	Fuel strainer	Paper element
Governor	Governor	Centrifugal all-speed mechanical type
Starting system	Electric	Pinion ring gear type starter motor
	Manual	Over-driven chain starting
Electrical system	Charger	Alternator (with built-in IC regulator)
Reduction reversing	Reduction gear	Sour gear constant-mesh system
Clutch system	Clutch	Wet single disc mechanical type

# 4. Performance Curves

## 1. YSM8-R, YSM8-Y

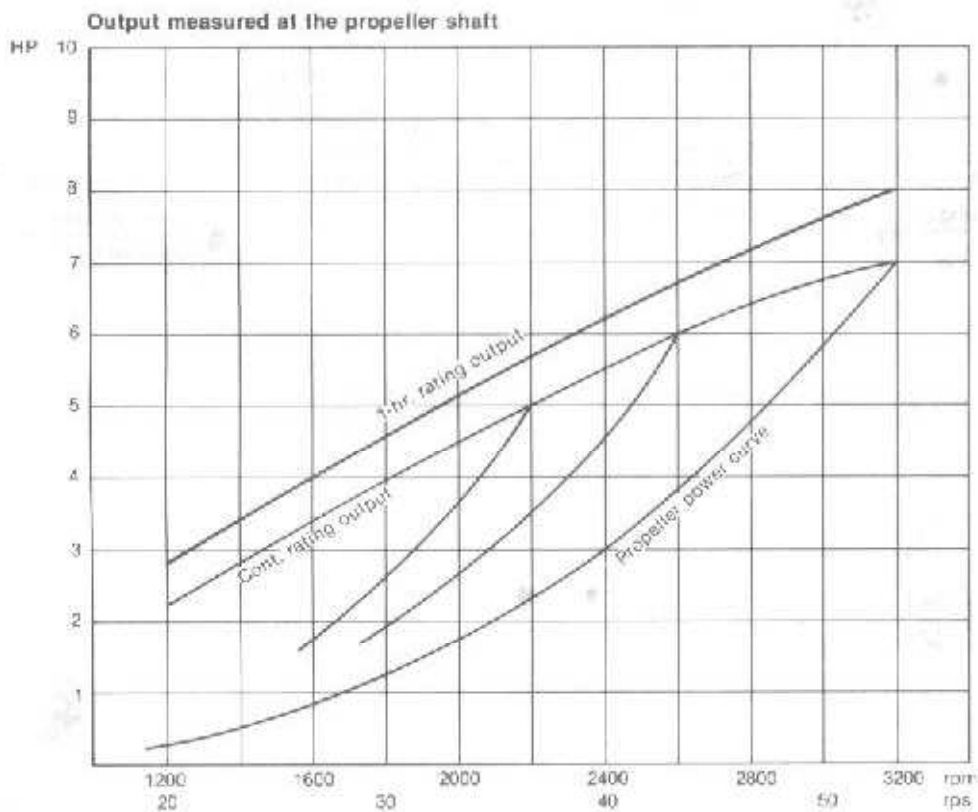
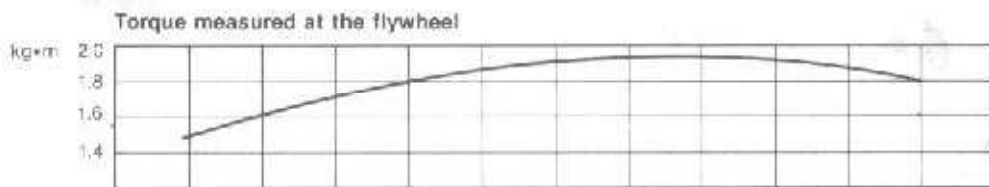
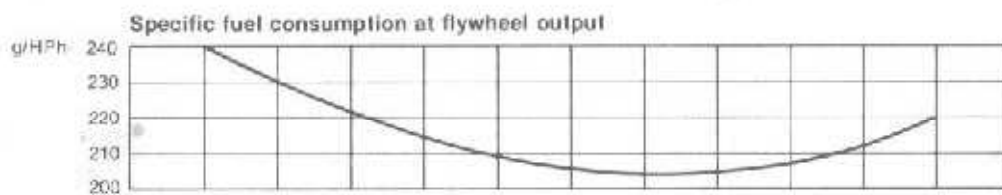
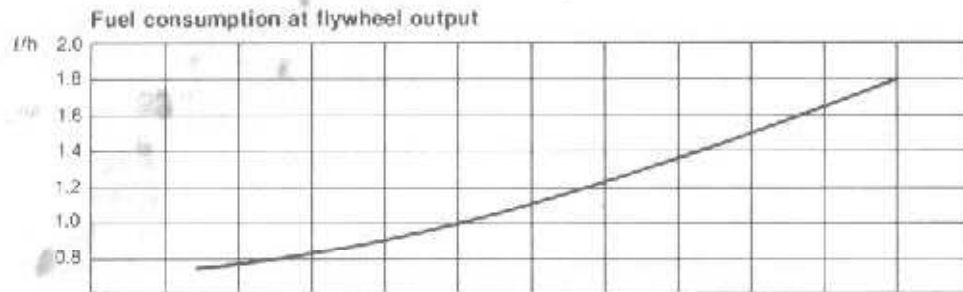

The Engine Flywheel Output is Approx. 5% Higher.

Note: These curves show the average performance of respective engines in test operation at our plant.

2. YSM12-R, YSM12-Y

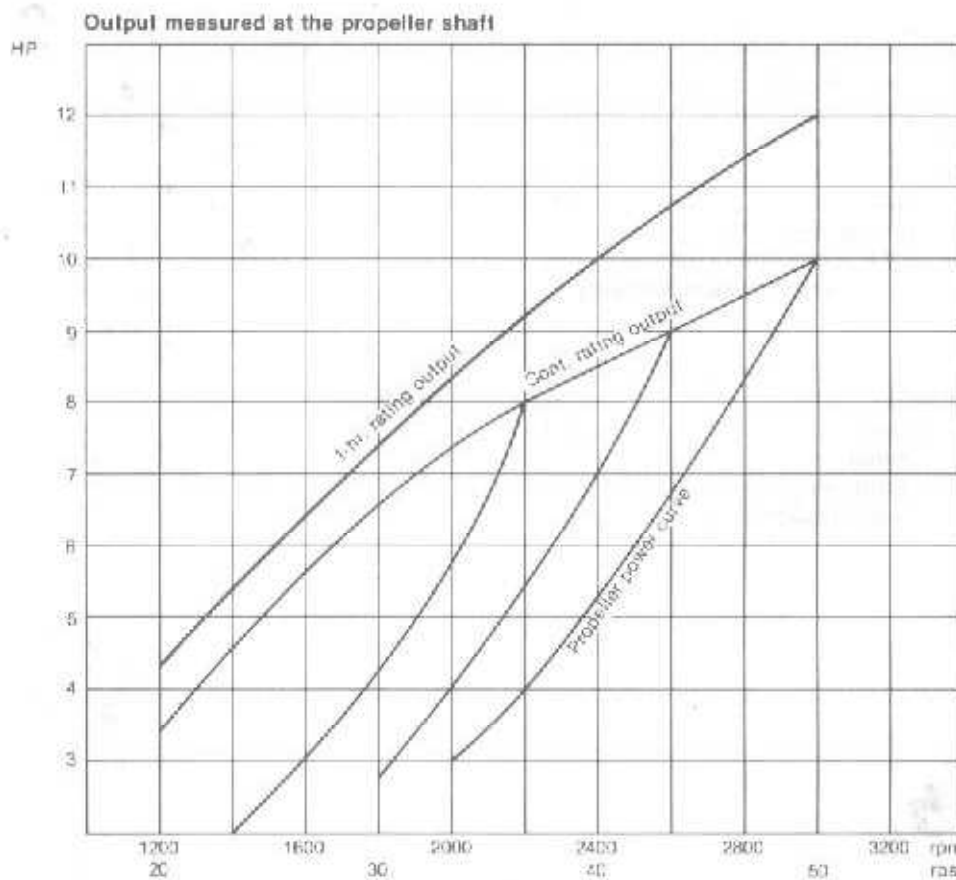
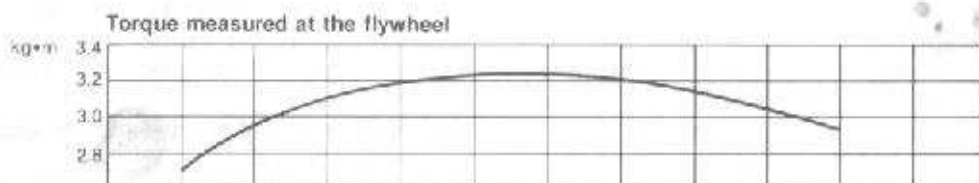
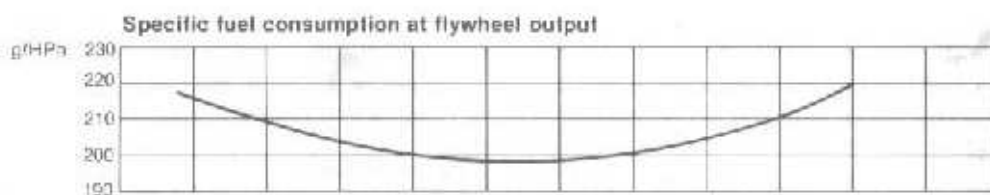
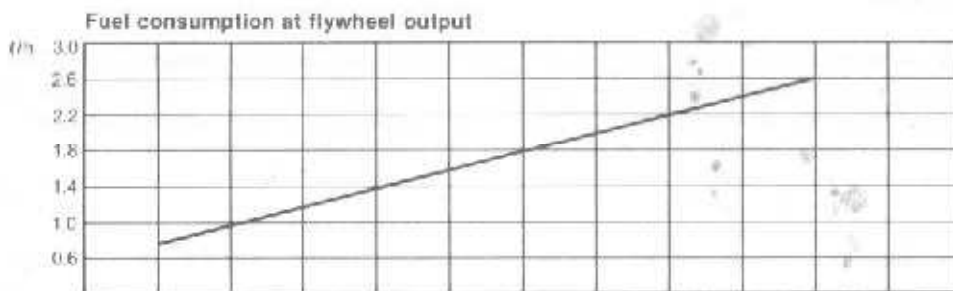

The Engine Flywheel Output is Approx. 5% Higher.  
Note: These curves show the average performance of respective engines in fast operation at our plant.

## 5. Features

### 1. Superior combustion performance

The unique Yanmar swirl precombustion chamber combustion system and new cooling system display superior combustion performance in all types of operation. Low-speed, low-load combustion performance, especially demanded for marine applications, is also superb, and stable performance is maintained over a wide range of speeds. Since starting characteristics are also excellent and warm-up is fast, full engine performance can be obtained within a short time.

### 2. Low operating costs

Excellent combustion and low friction reduce fuel costs, while the optimized piston shape and ring configuration and improved cooling system reduce oil consumption. Continuous operating time has been extended and operating costs reduced through improved durability.

### 3. Reduced weight and size

Reduction of the overall length and weight of the engine has been achieved by forging the clutch case and mounting of an aluminum alloy, and by adopting a new-type, small-size reduction and reversing gear, which is coupled direction to the flywheel. Moreover, since this is a horizontal type engine, its height has been significantly reduced, leaving much more space for cargo, etc.

### 4. Hundreds of hours of operation without an overhaul

The main moving parts, valve mechanism and combustion chamber have adopted designs and engineering materials which are ideally suited for high-speed engines. And since the cooling water is always kept at a constant high temperature by the thermostat, liner/ring wear is limited and the heat load around the combustion chamber is low, thereby ensuring lasting quality and increased durability.

### 5. Quiet operation

All the machine parts which produce reciprocating motions and are the source of vibrations in the engine, have been reduced in weight and perfectly balanced, cutting vibrations to a minimum. Also, because of the adoption of an intake silencer and mixing exhaust, noise has been greatly reduced without sacrificing engine speed.

### 6. Easy handling and simplified operation

- (1) The slope of the breather has been increased to withstand violent rollings, even up to 30°, thereby eliminating lubricating oil worries.
- (2) A bracket has been mounted on the clutch so that speed-clutch control can be performed with Morse remote control device.
- (3) By taking account of cabin electric power consumption, the capacity of the alternator has been increased.
- (4) Because of the adoption of alarm lamps which light up when there is a rise in the temperature of the cooling water or a drop in the pressure of the lubricating oil, engine troubles are prevented.

### 7. Easy installation

- (1) The four-point support type engine installing leg has greatly facilitated engine installation.
- (2) Since the instrument panel can be installed separately it can be placed anywhere on board for easy monitoring.
- (3) Rubber hoses are employed for the easy installation of on-board piping.
- (4) Electrical wiring can be connected quickly and easily with connectors.

# 6. Engine Cross-section

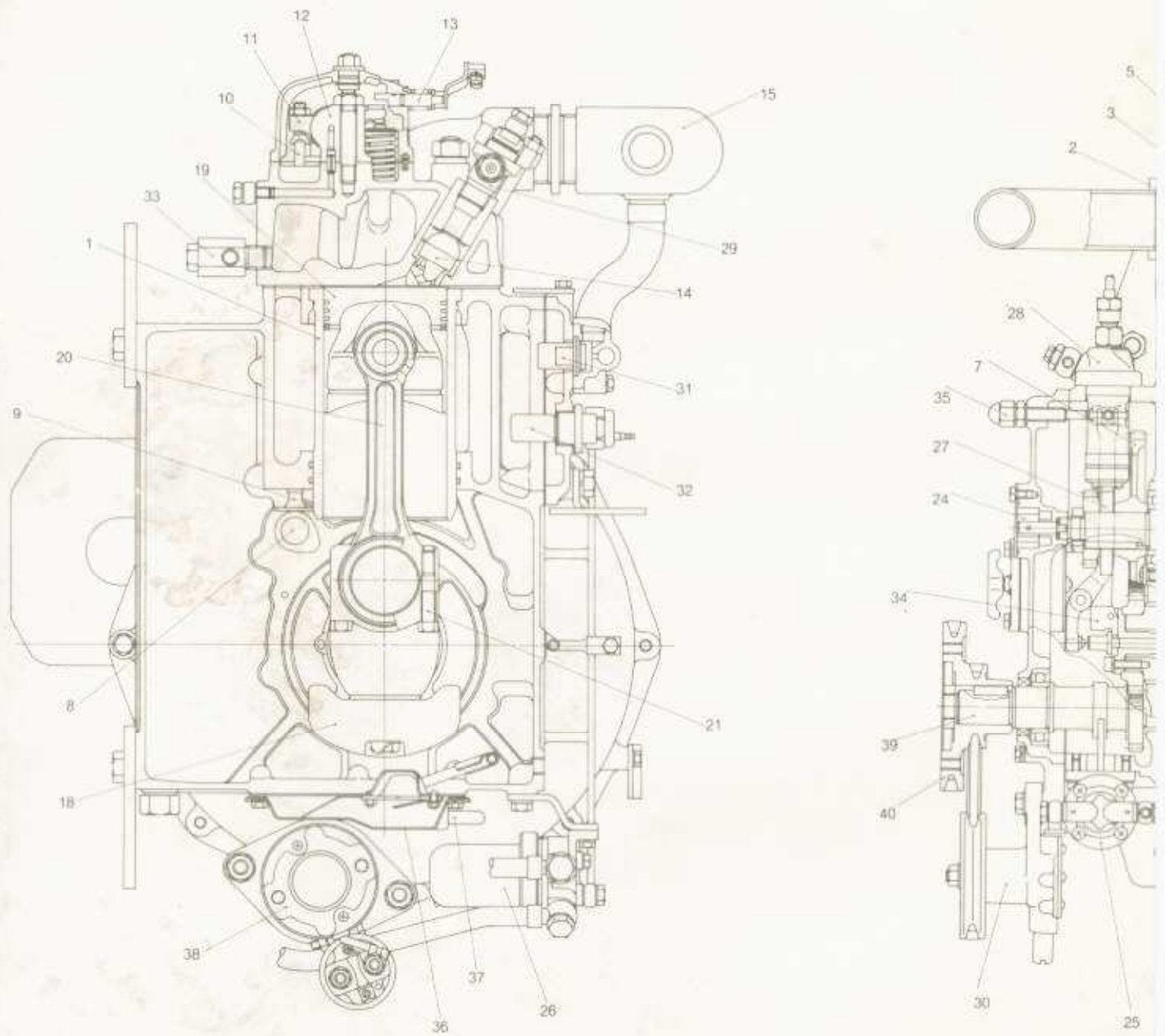



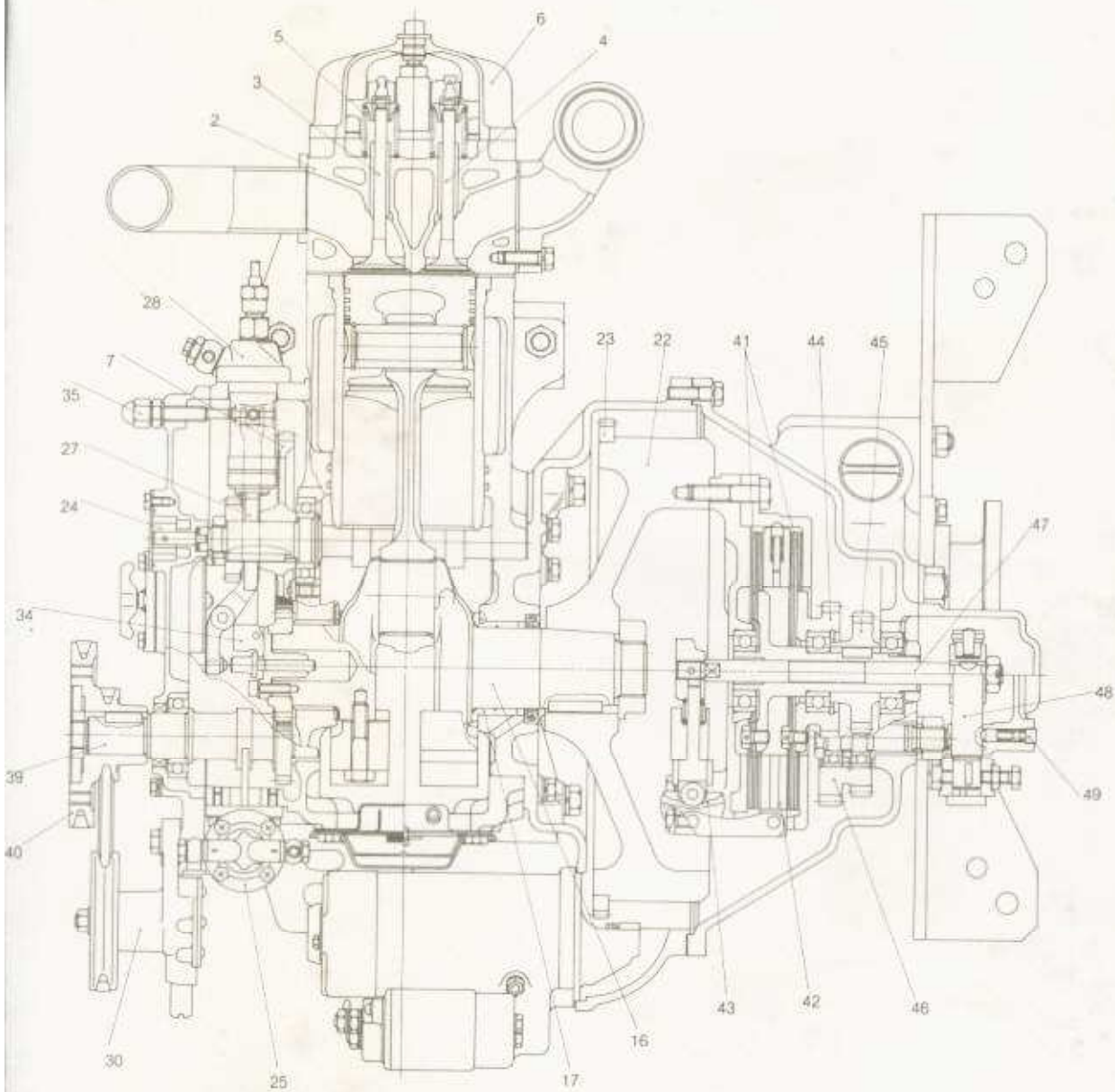

- 1 Cylinder liner
- 2 Cylinder head
- 3 Intake valve
- 4 Exhaust valve
- 5 Valve spring
- 6 Valve rocker arm
- 7 Camshaft gear
- 8 Camshaft
- 9 Tappet
- 10 Push rod
- 11 Valve rocker arm
- 12 Valve rocker arm
- 13 Decompression
- 14 Precompression
- 15 Mixing elbow
- 16 Crankshaft
- 17 Main bearing
- 18 Balance weight
- 19 Piston
- 20 Connecting rod
- 21 Connecting rod
- 22 Flywheel
- 23 Ring gear
- 24 Lubricating oil
- 25 Fuel feed pump
- 26 Fuel filter
- 27 Fuel cam
- 28 Fuel pump
- 29 Fuel injection nozzle
- 30 Cooling water pump
- 31 Thermostat
- 32 Anticorrosion zinc
- 33 Cooling water distributor
- 34 Governor weight
- 35 Fuel injection line
- 36 Cylinder rear cover
- 37 Breather pipe
- 38 Starter motor
- 39 P.T.O. shaft
- 40 P.T.O. shaft pull
- 41 Friction disc
- 42 Friction plate
- 43 V-lever
- 44 Reverse gear
- 45 Forward gear
- 46 Idle gear
- 47 Shifting shaft
- 48 Fork shaft
- 49 Neutral point sensor

# 7. Exterior Views

## 7-1 YSM8-R

mm (in.)

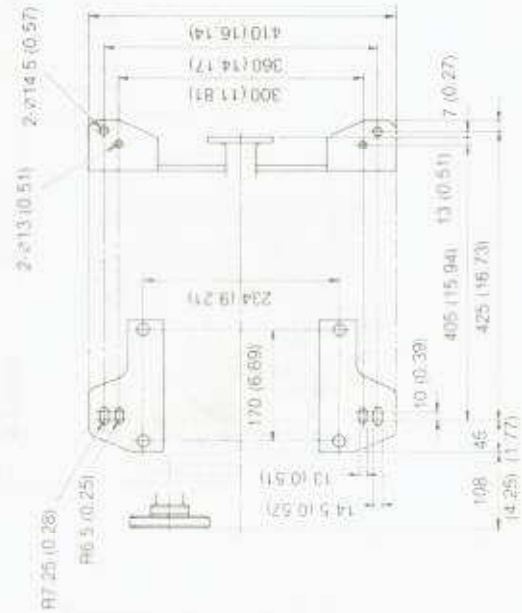
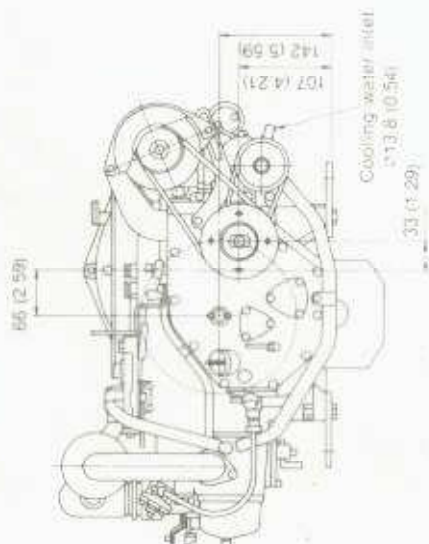
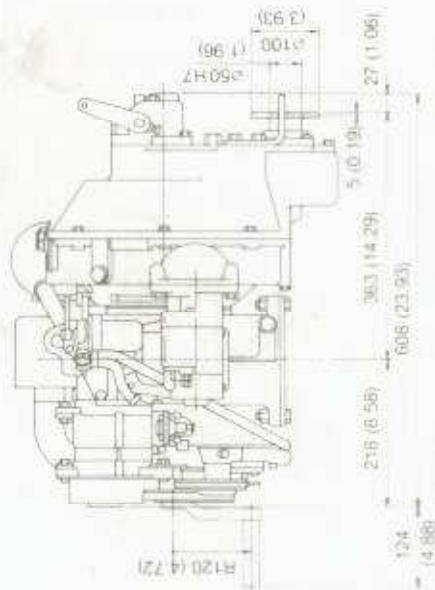
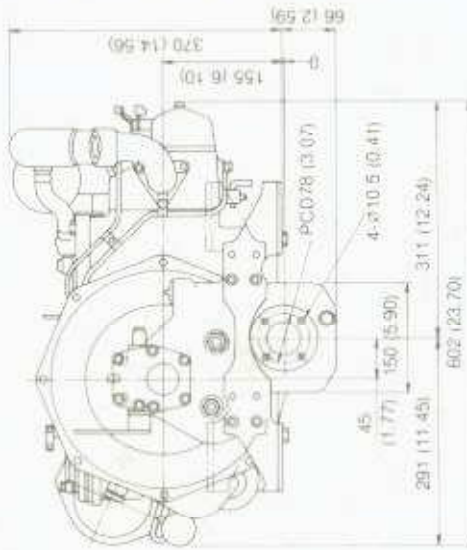







## 8. System Diagrams

### 8-1 Cooling system

#### 8-1.1 YSM8-R, YSM12-R

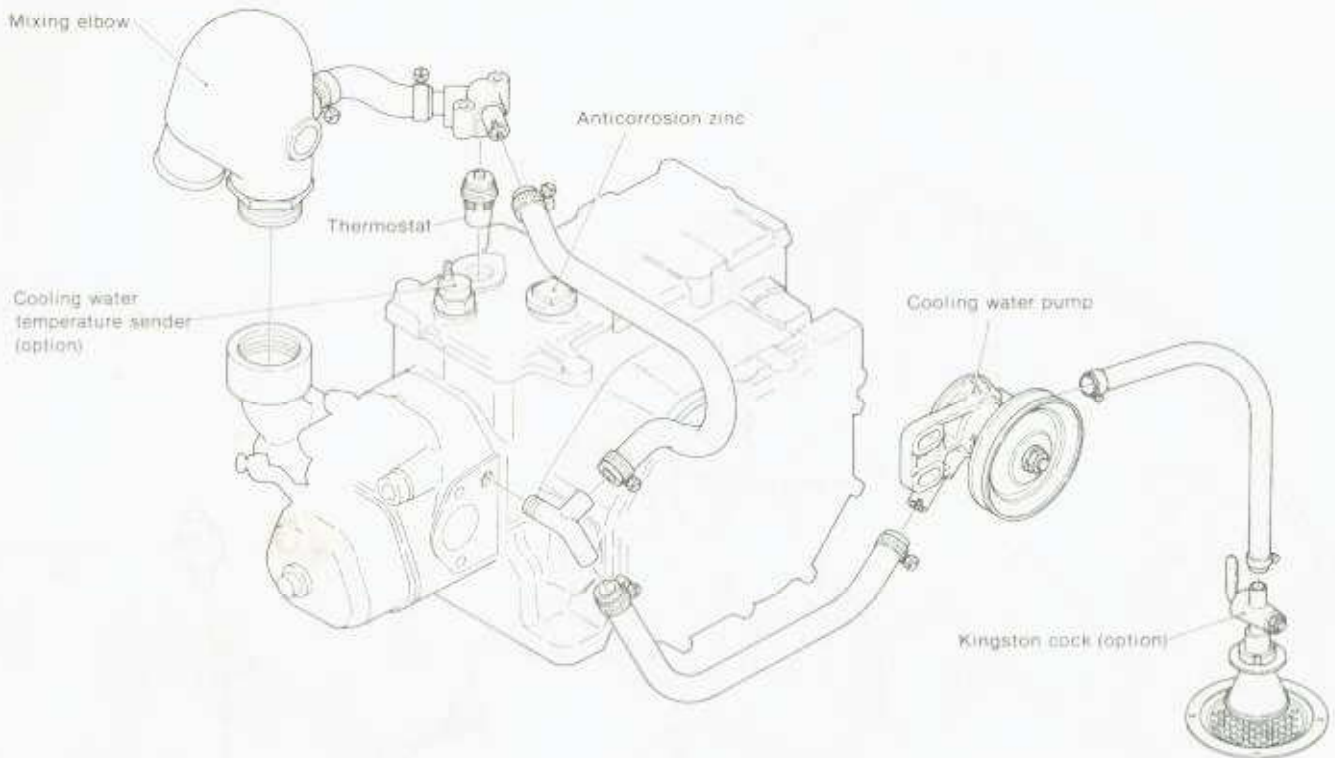

#### 8-1.2 YSM8-Y, YSM12-Y

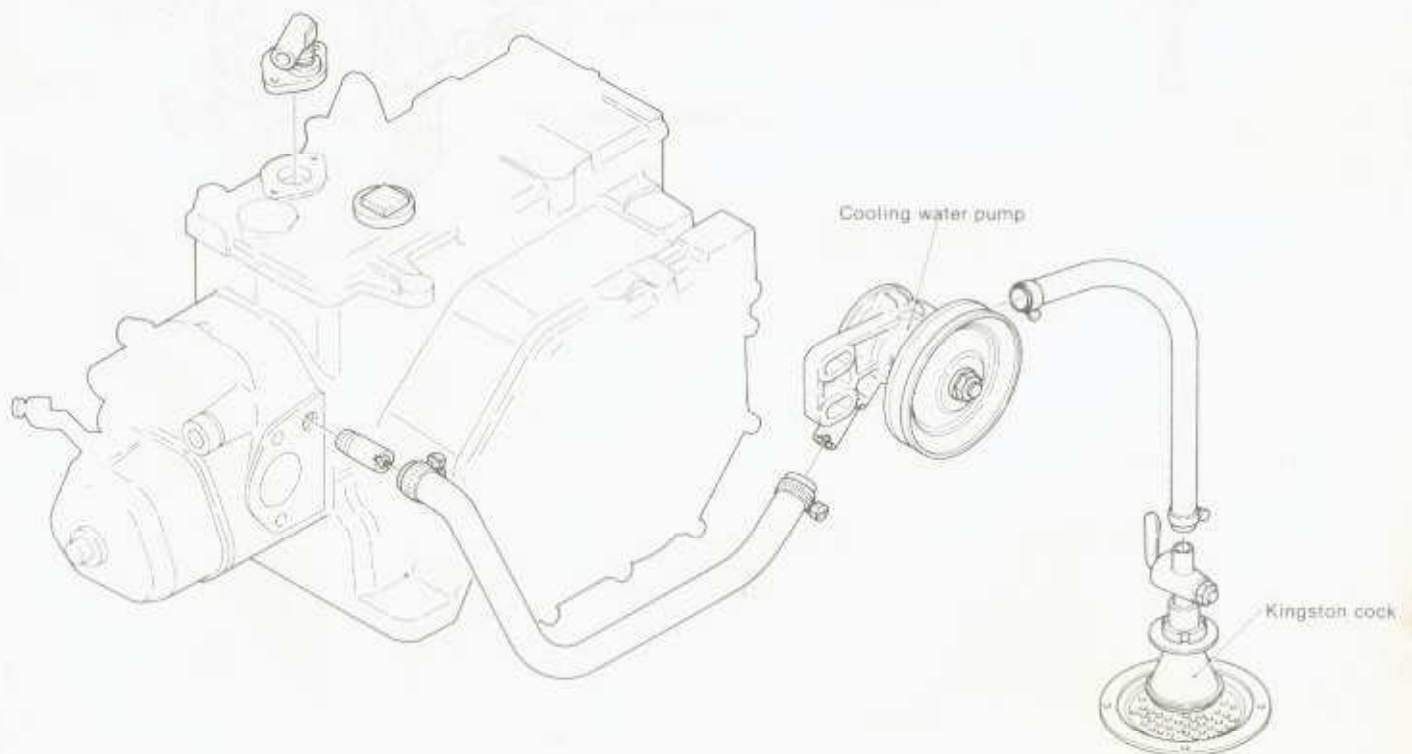

8-2 Lubrication system

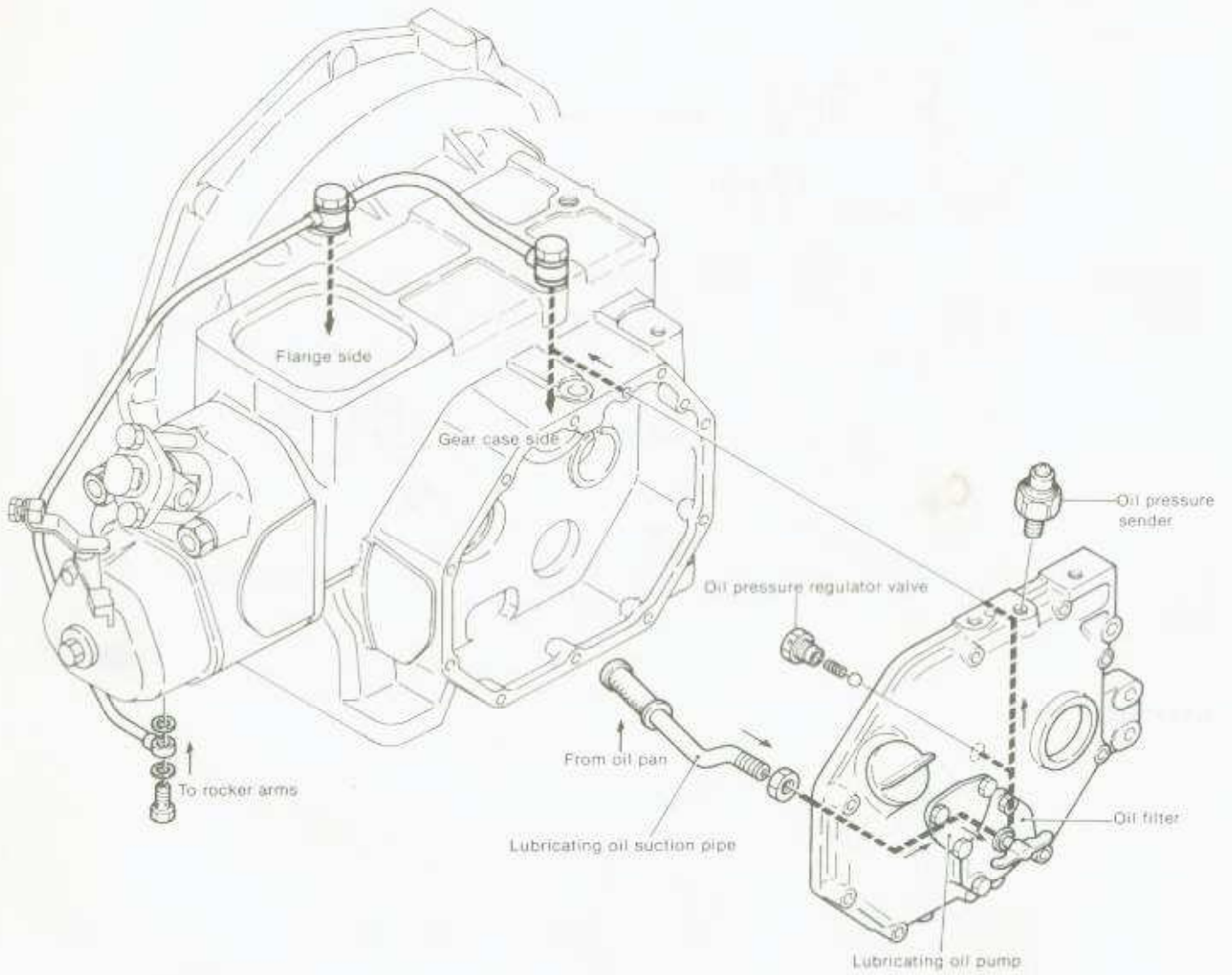

8-3 Fuel system

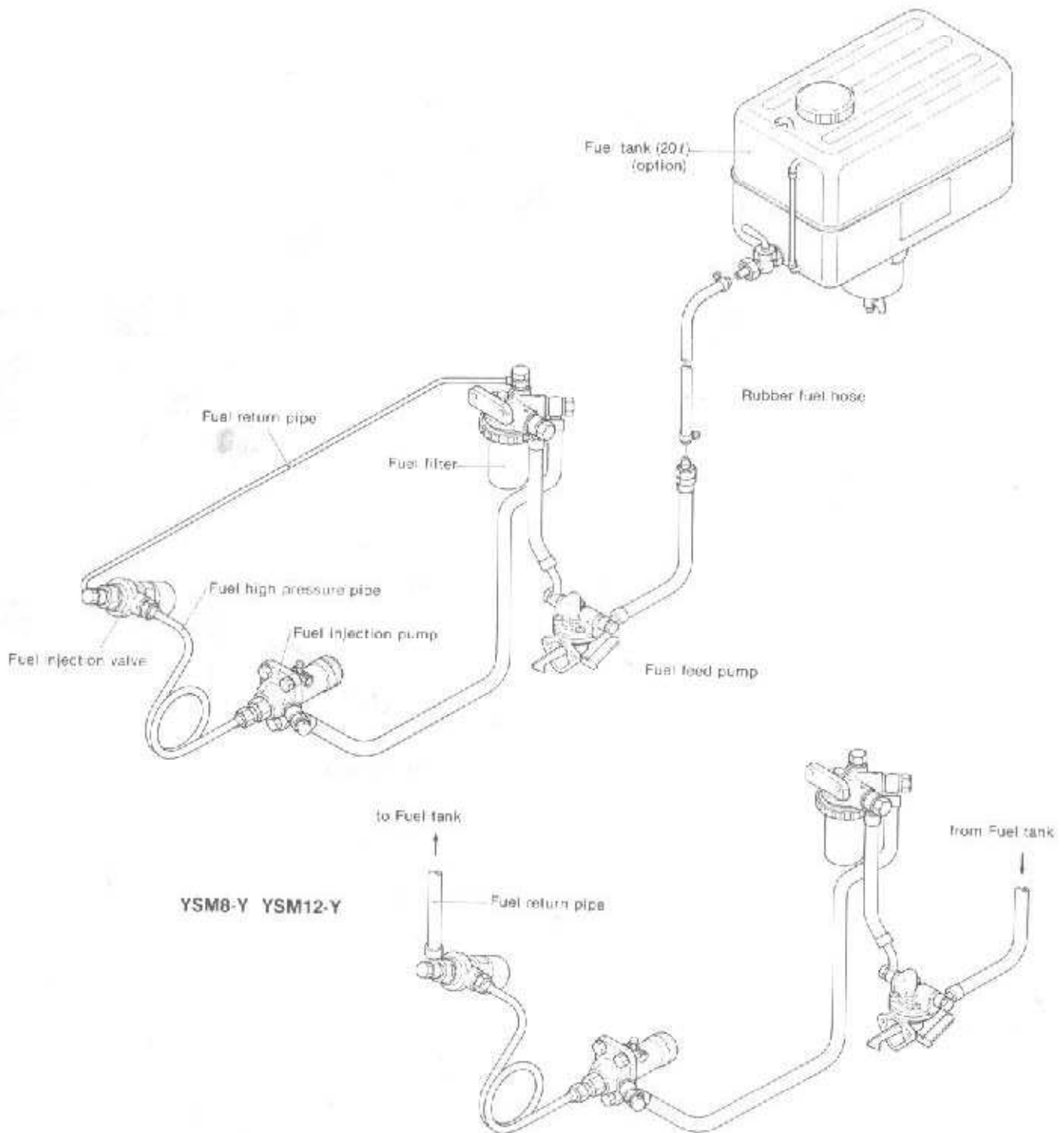



8-4 Electrical system

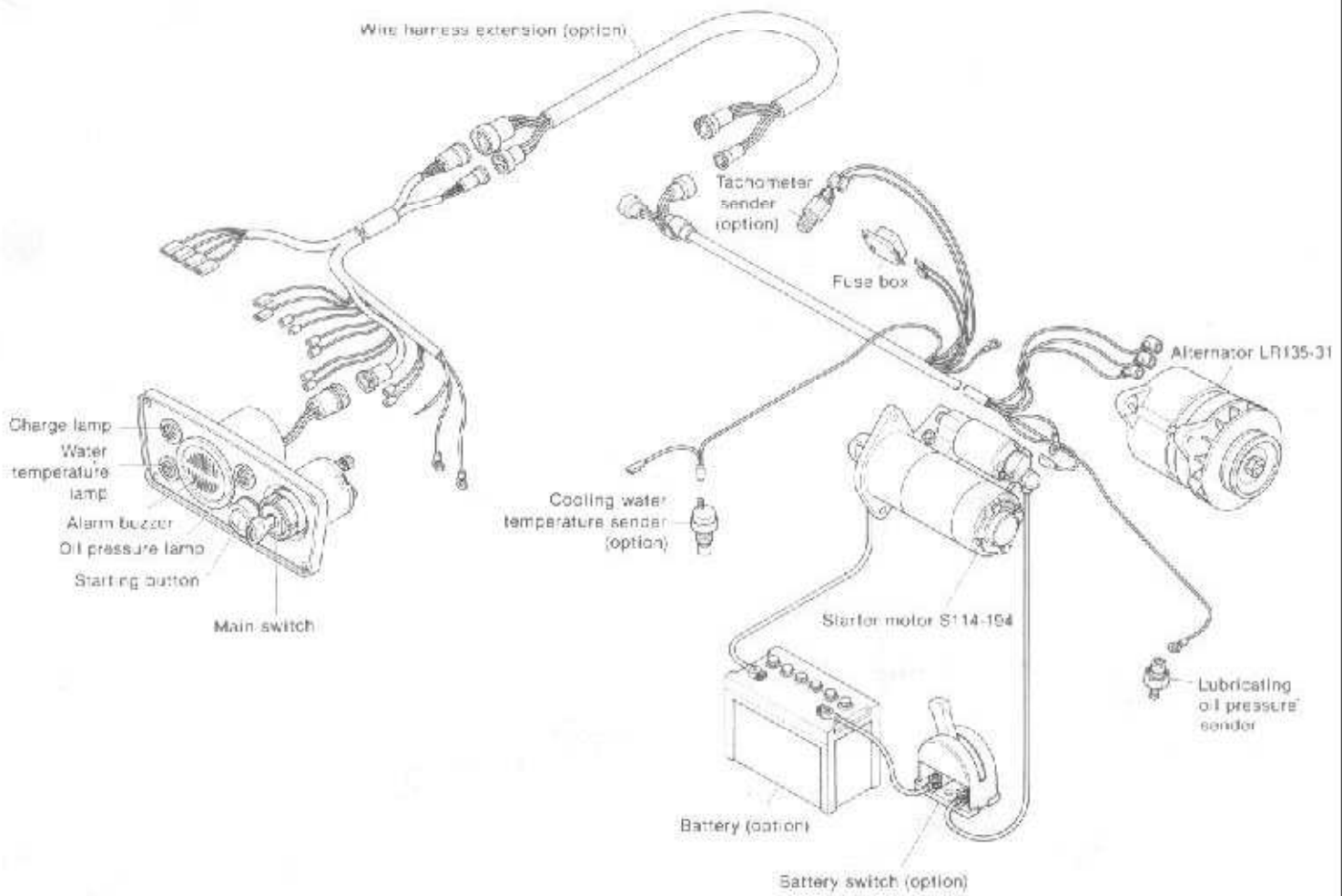

8-5 Timing gear train

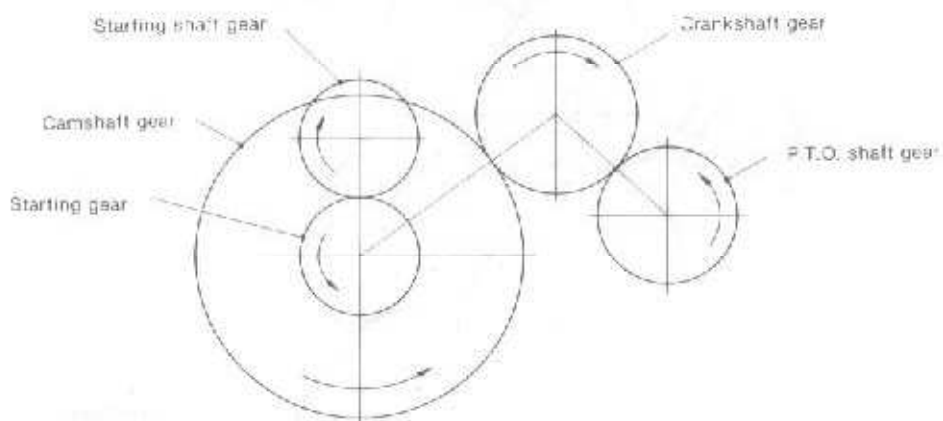
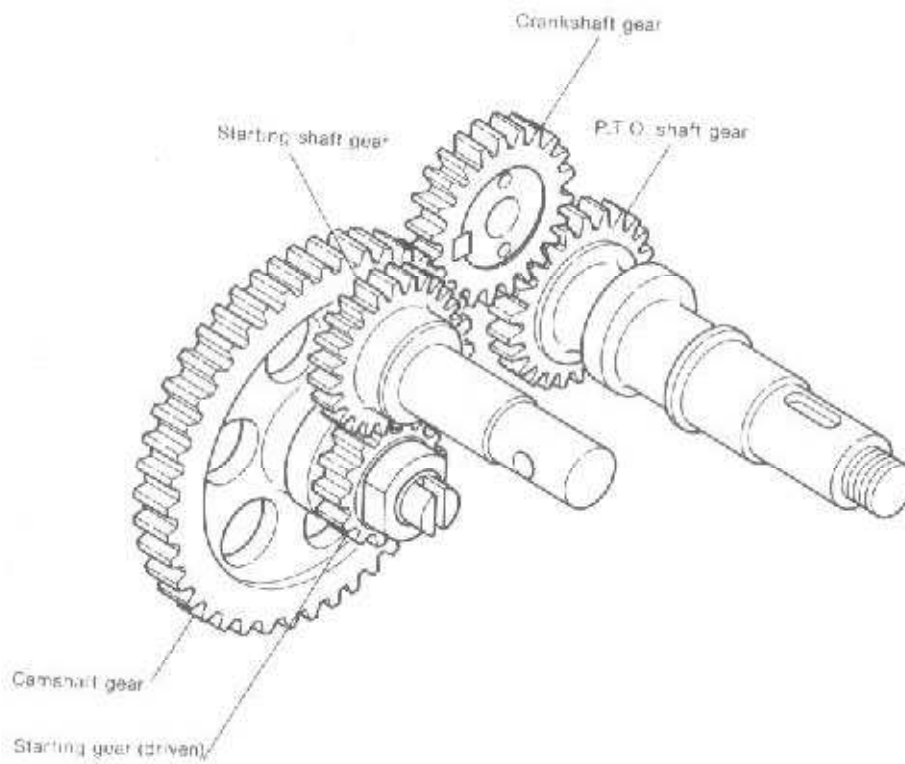

8-6 Reduction reversing power transmission system

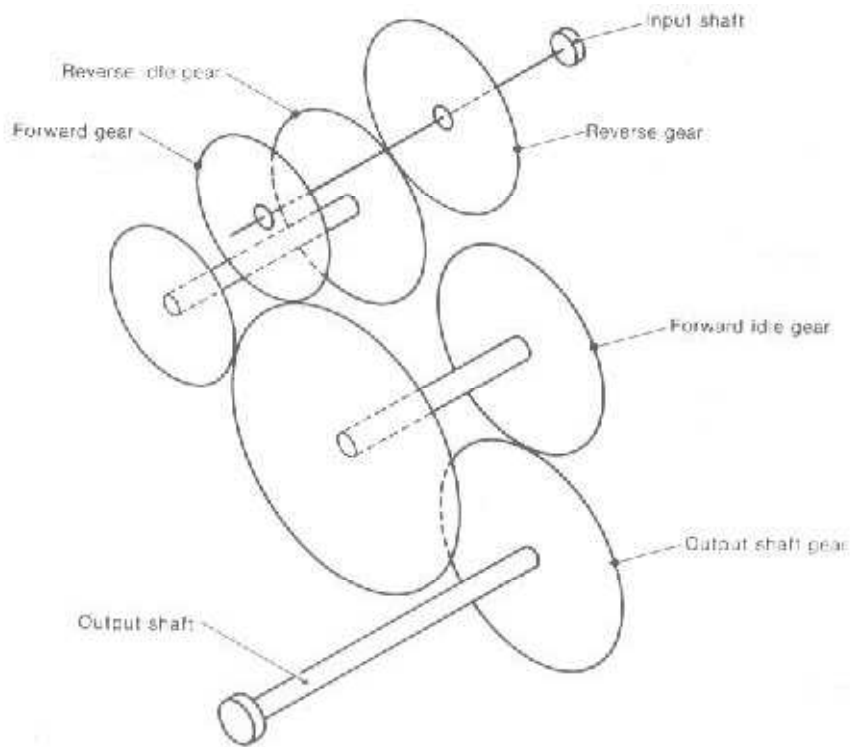
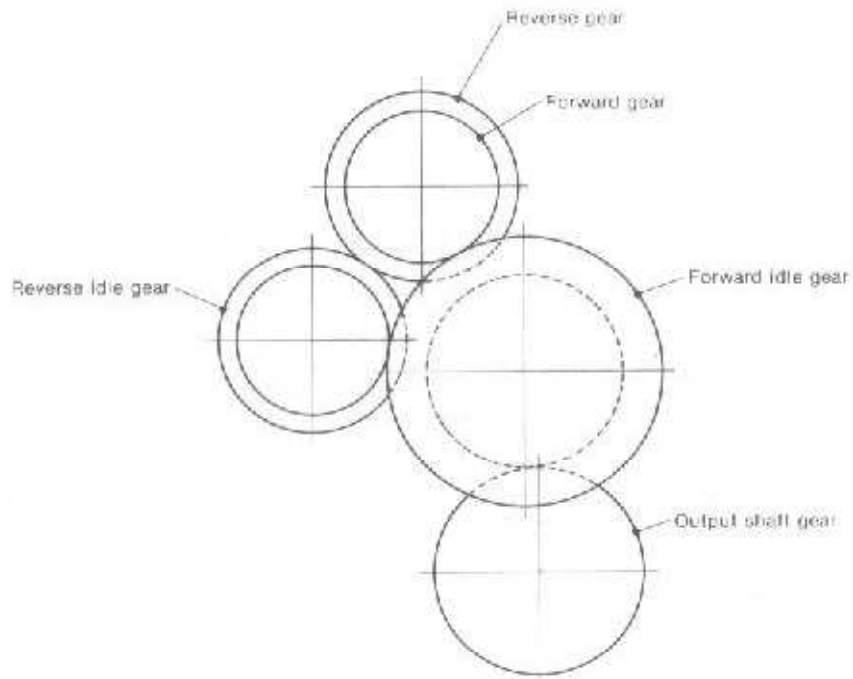

8-7 Remote control system

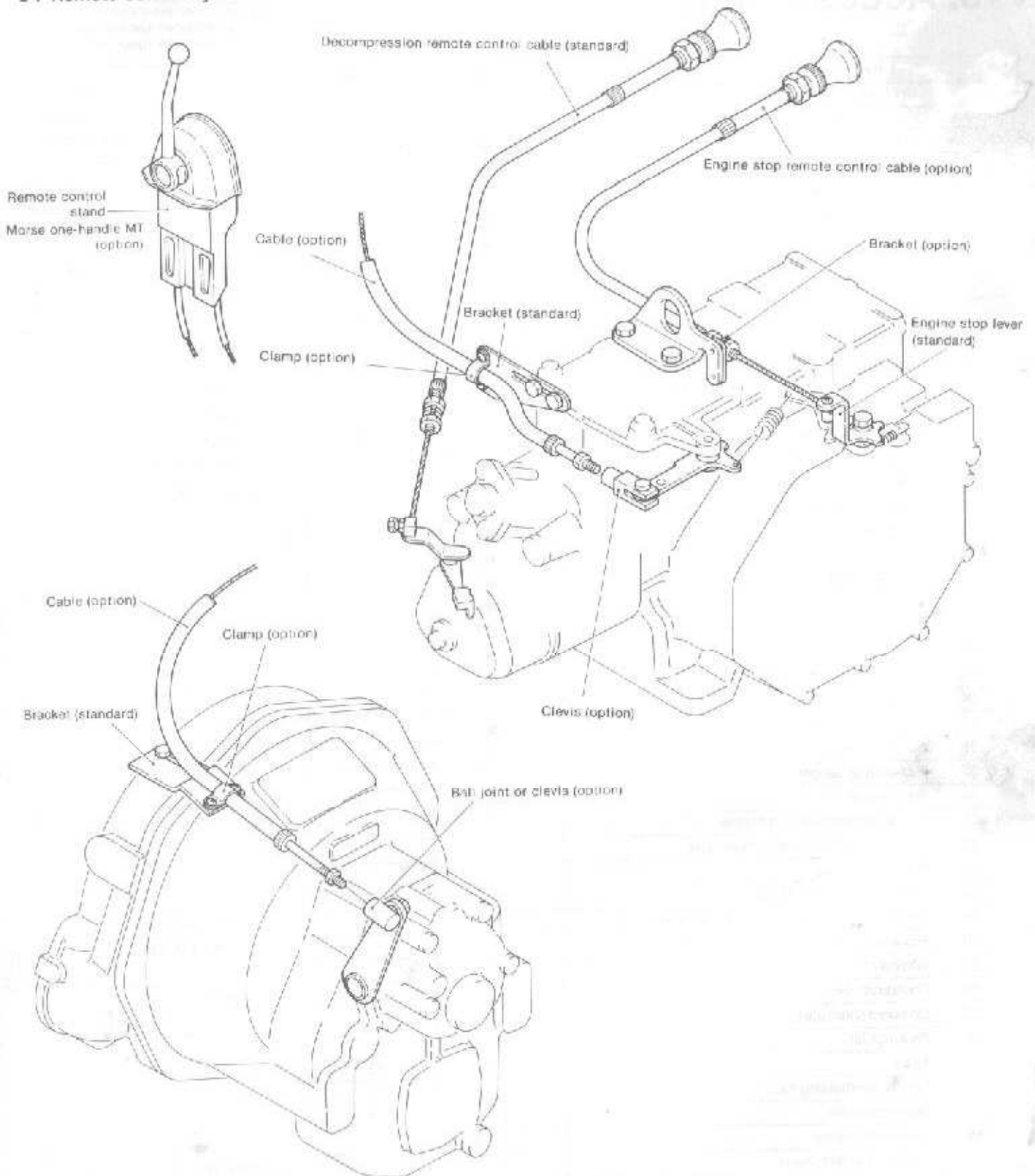

## 9. Accessories

- Standard accessories packed with engine  
● Standard accessories mounted on engine  
△ Optional accessories packed with engine  
▲ Optional accessories mounted on engine

	Part name	R-type	Y-type	Remarks
1	Dry type exhaust silencer	—	○	
2	Exhaust pipe	—	○	
3	Water mixing elbow	●	—	U-type
4	Thermostat for cooling water	●	—	
5	Fuel oil tank with rubber hose	△	△	2-meter fuel hose
6	Fuel oil feed pump (mechanical type)	●	●	
7	Fuel oil strainer	●	●	
8	Chain starting device (stern side)	▲	▲	with stern side decomp. lever
9	Lube oil evacuation pump	△	△	
10	Bilge pump (mechanical type)	▲	▲	
11	Bilge hose and strainer	△	△	
12	Kingston cock with cooling water hose	△	○	
13	Remote control cable for decompression	○	—	3-meter
14	Cable for engine stop device	△	—	3-meter
15	Speed control lever with cable	—	●	1.5-meter
16	Single lever control (Morse MT-type)	△	—	with two 4-meter cables
17	Bracket for clutch remote control cable	●	—	
18	Bracket for speed remote control cable	●	—	
19	Flywheel ring gear	●	—	
20	Starting motor	●	—	
21	A.C. generator	●	—	
22	Wireharness	●	—	
23	Dash board (with 3-meter wireharness)	○	—	
24	Fuse box	●	—	
25	Lube oil pressure sender	●	—	
26	Lube oil indicator	—	●	
27	Cooling water temperature sender	●	—	
28	Battery switch	△	—	with screws
29	Tachometer sender	△	—	
30	Tachometer	△	—	
31	Flexible mountings (fixed type)	△	—	4pcs/unit
32	Flexible mountings (adjustable type)	△	—	4pcs/unit
33	Flexible coupling	△	—	with nuts
34	Exhaust flange and elbow	△	—	
35	Propeller shaft half coupling (solid, taper bored)	△	○	with bolts and nuts
36	Propeller shaft half coupling (slit type)	△	—	with bolts and nuts
37	Wireharness coupler for open board	△	—	
38	Foundation bolts	—	○	4pcs/unit
39	On board spare parts kit	△	○	
40	Packings kit	△	△	
41	Tools	○	○	
42	Special overhauling tools	△	△	
43	Starting handle	○	○	
44	Operation manual	○	○	
45	Wireharness extension	△	—	3-meter or 6-meter
46	Intake silencer	●	—	