

CHAPTER 14

# DISASSEMBLY AND REASSEMBLY

1. Disassembly and Reassembly Precautions .....	14-1
2. Disassembly and Reassembly Tools .....	14-2
3. Other .....	14-11
4. Disassembly .....	14-12
5. Reassembly .....	14-16
6. Tightening Torque .....	14-21
7. Packing Supplement and Adhesives .....	14-22

## DISASSEMBLY AND REASSEMBLY

This chapter covers the most efficient method of disassembling and reassembling the engine. Some parts may not have to be removed depending on the maintenance and inspection objective. In this case, removal is unnecessary and disassembling in accordance with this section is not required.

However, if you follow the disassembly and reassembly procedures, adjustment methods, and precautions described in this chapter, you should be able to prevent subsequent troubles and a loss in engine performance after reassembly. The engine must be test-run to confirm that the engine is functioning properly and delivering full performance. Since this chapter does not cover detailed disassembly and reassembly procedures for each part, refer to pertinent chapters for details.

### 1. Disassembly and Reassembly Precautions

- (1) Record the parts that require replacement, and replace them with new parts during reassembly.  
Be careful not to reassemble with the old parts.
- (2) Do not forget adhesives and packing agents for sealing during reassembly.  
Packing of the specified quality and packing agents matched to the packing material must be used.
- (3) The prescribed tightening torque must be observed when tightening bolts and nuts. Moreover, since the strength of the bolts and nuts depends on their material, be sure to use the correct bolts and nuts at their proper places.

Special bolts, nuts . . . Head cover, rod bolts, flywheel, etc.

Strong bolts . . . . . Bolts marked (7) (JIS. 7T)



Common bolts, nuts . . . Unmarked (JIS. 4T)

In addition, check the disassembly and reassembly precautions for each engine model.

## 2. Disassembly and Reassembly Tools

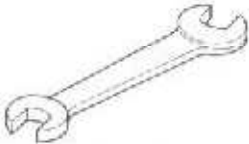
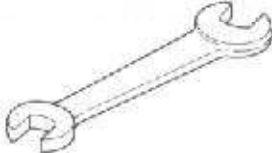
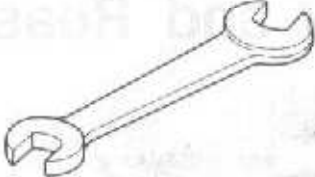

The following tools are necessary when disassembling and reassembling the engine. These tools must be used according to disassembly process and location.

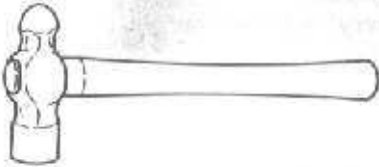
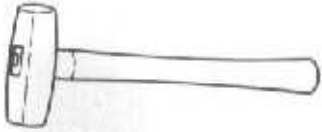

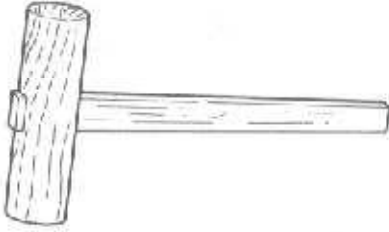
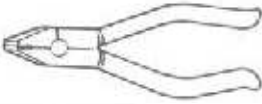

### 2-1 General handtools

Name of tool	Shape	Remarks
Spanner		10 × 13
Spanner		17 × 19
Spanner		22 × 24
Screwdriver for + (cross recessed head) screws		
Screwdriver for - (Phillips head) screws		
Steel hammer		
Copper hammer		

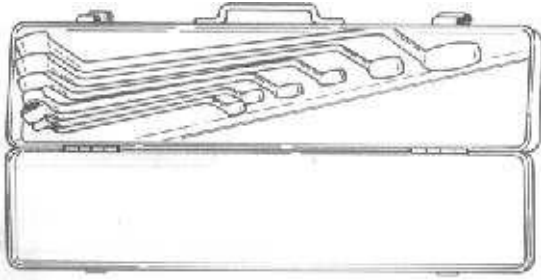
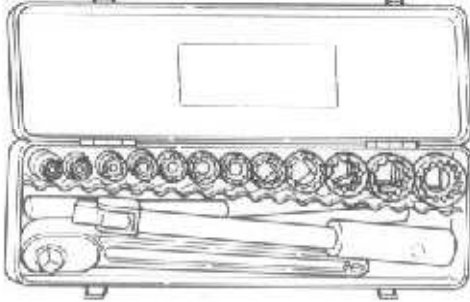
Chapter 14 Disassembly and Reassembly  
 2. Disassembly and Reassembly Tools

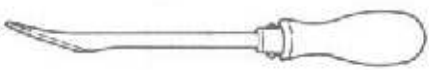

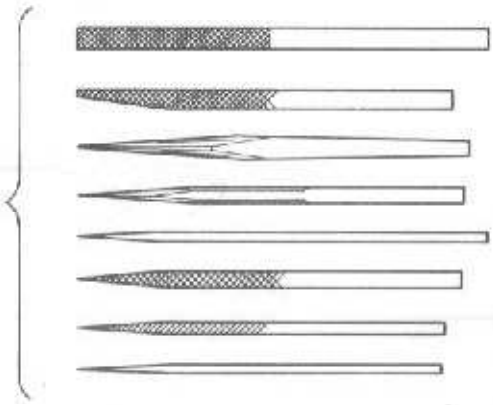
SM/YSM

Name of tool	Shape	Remarks
Mallet		
Nipper		
Plier		
Offset wrench		1 set
Box spanner		1 set

Name of tool	Shape	Remarks
Scraper		
Lead rod		
File		1 set
Rod spanner for hexagon socket head screws		5 mm

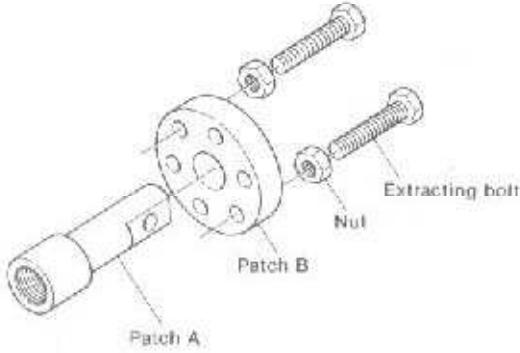
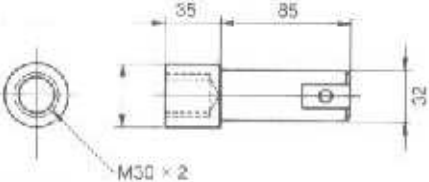
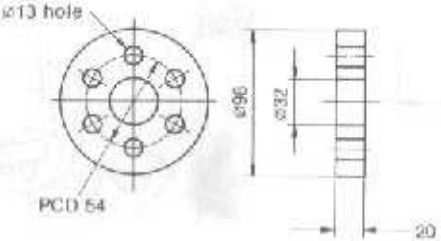
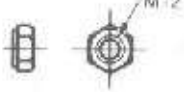
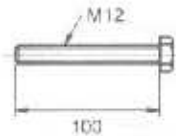

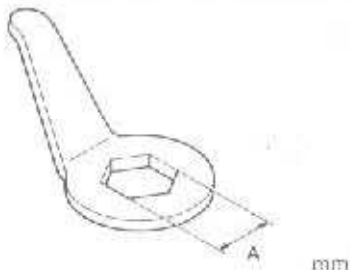
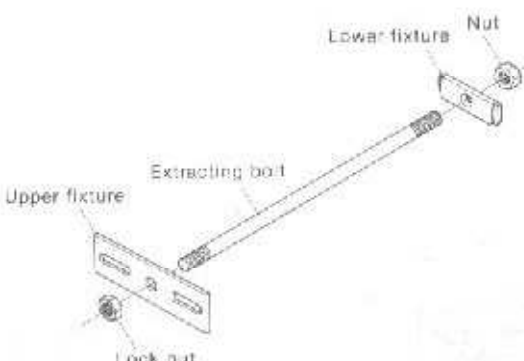
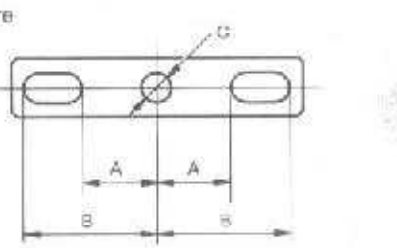
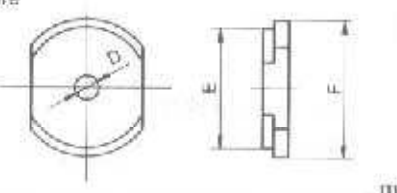

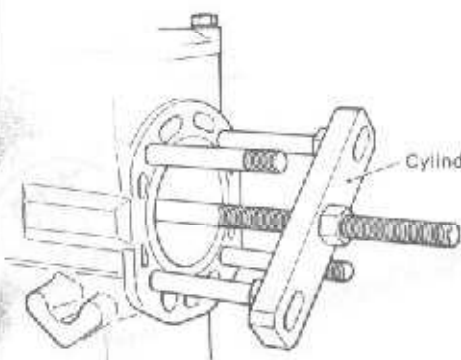
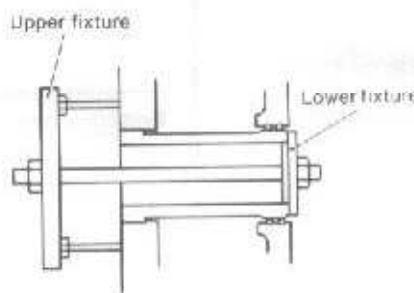
2-2 Special handtools

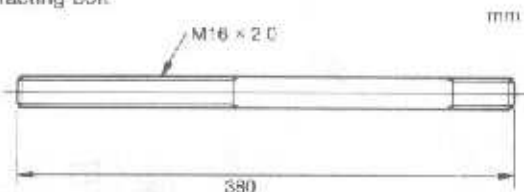
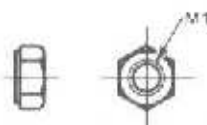
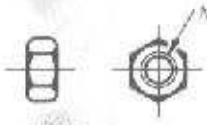
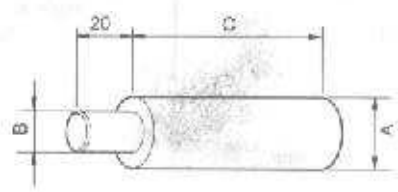
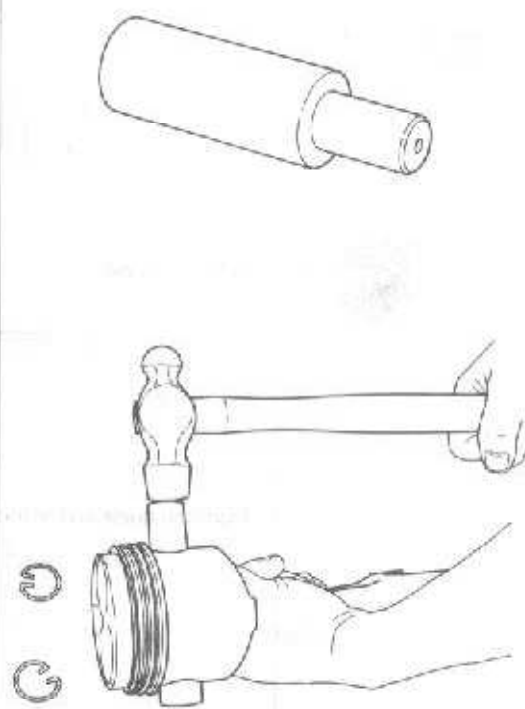
Name of hand tool	Shape and size	Application
Flywheel extractor (made to special order)		<p><b>CAUTION:</b> In the case of engines which use rolling bearings, be sure to employ the extracting tool so that no shock is applied in the direction of the crankshaft.</p>
	<p>Patch A</p>  <p>mm</p> <p>Code no. 104200-92110</p>	
	<p>Patch B</p>  <p>mm</p> <p>Code no. 104200-92120</p>	
	<p>Hexagon nut</p>  <p>Code no. 26716-120002</p>	
	<p>Extracting bolt</p>  <p>mm</p> <p>Code no. 104200-92130</p>	

Name of hand tool	Shape and size	Application																																				
End nut spanner (made to special order)	 <table border="1" data-bbox="430 616 893 716"> <thead> <tr> <th>Model</th> <th>Size</th> <th>Code No.</th> </tr> </thead> <tbody> <tr> <td>YSM8</td> <td>47</td> <td>104211~92100</td> </tr> <tr> <td>YSM12</td> <td>57</td> <td>104511~92100</td> </tr> </tbody> </table>	Model	Size	Code No.	YSM8	47	104211~92100	YSM12	57	104511~92100																												
Model	Size	Code No.																																				
YSM8	47	104211~92100																																				
YSM12	57	104511~92100																																				
Liner extractor (made to special order)	  <table border="1" data-bbox="430 1467 893 1624"> <thead> <tr> <th rowspan="2">Model</th> <th colspan="3">Size</th> <th rowspan="2">Code No.</th> </tr> <tr> <th>A</th> <th>B</th> <th>C</th> </tr> </thead> <tbody> <tr> <td>YSM8</td> <td>59</td> <td>85</td> <td>∅18</td> <td>103336~92020</td> </tr> <tr> <td>YSM12</td> <td>43</td> <td>74</td> <td>∅18</td> <td>172200~92020</td> </tr> </tbody> </table>  <table border="1" data-bbox="430 1870 893 2016"> <thead> <tr> <th rowspan="2">Model</th> <th colspan="3">Size</th> <th rowspan="2">Code No.</th> </tr> <tr> <th>D</th> <th>E</th> <th>F</th> </tr> </thead> <tbody> <tr> <td>YSM8</td> <td>∅18</td> <td>∅64.5</td> <td>∅94</td> <td>101400~92010</td> </tr> <tr> <td>YSM12</td> <td>∅18</td> <td>∅74.5</td> <td>∅84</td> <td>101300~92010</td> </tr> </tbody> </table>	Model	Size			Code No.	A	B	C	YSM8	59	85	∅18	103336~92020	YSM12	43	74	∅18	172200~92020	Model	Size			Code No.	D	E	F	YSM8	∅18	∅64.5	∅94	101400~92010	YSM12	∅18	∅74.5	∅84	101300~92010	 <p>Liner extractor</p>  <p>Cylinder liner puller</p>  <p>Upper fixture Lower fixture</p>
Model	Size			Code No.																																		
	A	B	C																																			
YSM8	59	85	∅18	103336~92020																																		
YSM12	43	74	∅18	172200~92020																																		
Model	Size			Code No.																																		
	D	E	F																																			
YSM8	∅18	∅64.5	∅94	101400~92010																																		
YSM12	∅18	∅74.5	∅84	101300~92010																																		

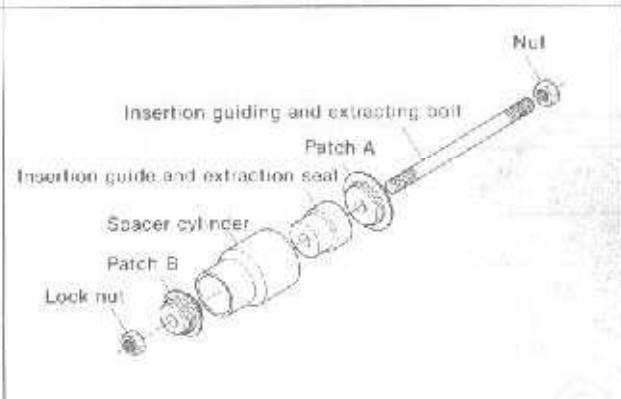
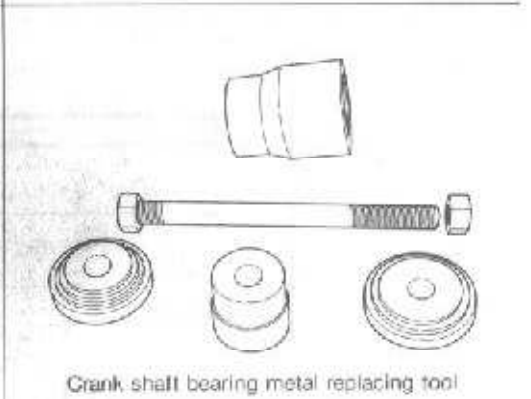
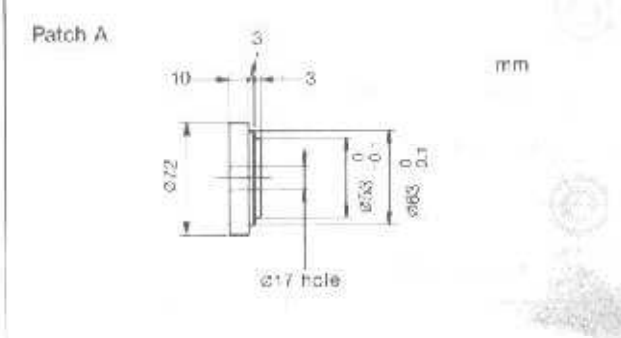
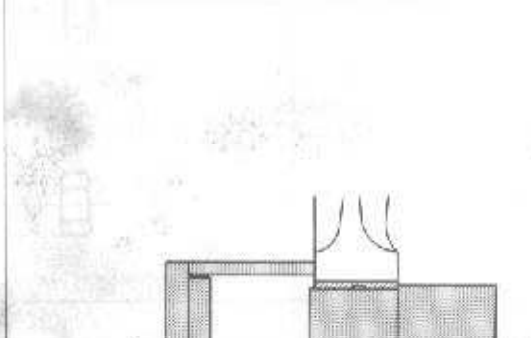
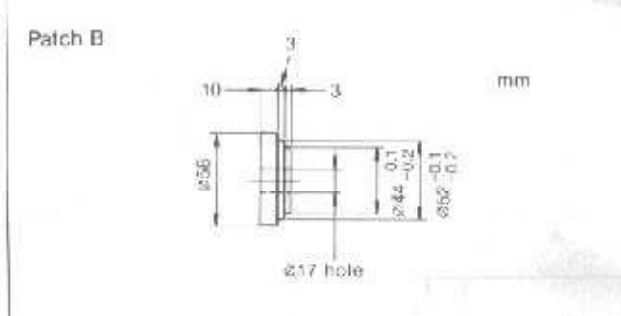
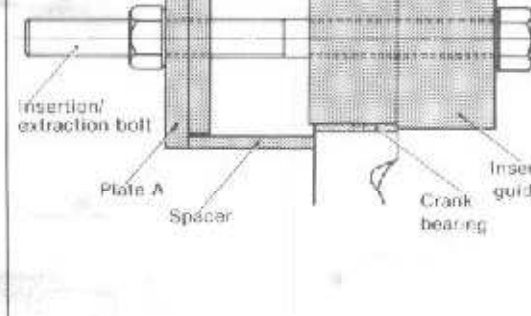
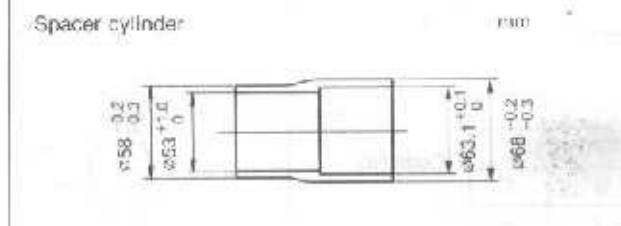
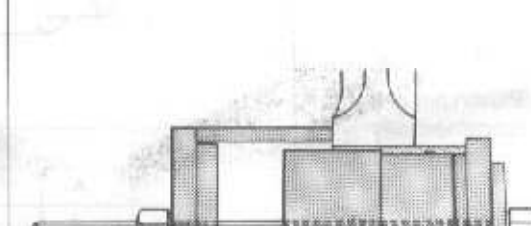
Name of hand tool	Shape and size	Application																		
Liner extractor (made to special order)	Extracting bolt  <p style="text-align: right;">mm</p> <p style="text-align: right;">Code no. 103338-02030</p>																			
	Hexagon nut  <p style="text-align: right;">Code no. 26716-160002</p>  <p style="text-align: right;">Code no. 28756-160002</p>																			
Piston pin extractor (commercially available product)	 <p style="text-align: right;">mm</p> <table border="1" data-bbox="391 1456 933 1635"> <thead> <tr> <th rowspan="2">Model</th> <th colspan="3">Size</th> <th rowspan="2">Code No.</th> </tr> <tr> <th>A</th> <th>B</th> <th>C</th> </tr> </thead> <tbody> <tr> <td>YSM8</td> <td><math>\varnothing 22_{-0.5}^0</math></td> <td><math>\varnothing 12_{-0.5}^0</math></td> <td>85</td> <td></td> </tr> <tr> <td>YSM12</td> <td><math>\varnothing 27_{-0.5}^0</math></td> <td><math>\varnothing 17.5_{-0.5}^0</math></td> <td>95</td> <td></td> </tr> </tbody> </table>	Model	Size			Code No.	A	B	C	YSM8	$\varnothing 22_{-0.5}^0$	$\varnothing 12_{-0.5}^0$	85		YSM12	$\varnothing 27_{-0.5}^0$	$\varnothing 17.5_{-0.5}^0$	95		
Model	Size			Code No.																
	A	B	C																	
YSM8	$\varnothing 22_{-0.5}^0$	$\varnothing 12_{-0.5}^0$	85																	
YSM12	$\varnothing 27_{-0.5}^0$	$\varnothing 17.5_{-0.5}^0$	95																	

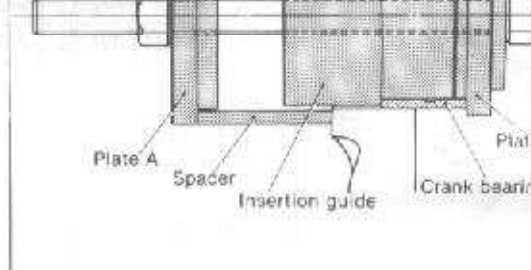

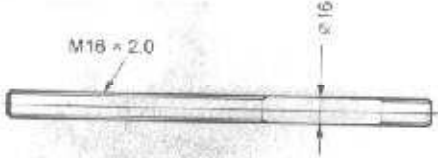
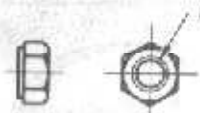
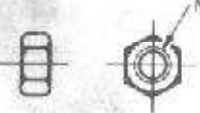

Name of hand tool	Shape and size	Application																					
Crankshaft bearing metal replacing tool (made to special order)		 <p>Crank shaft bearing metal replacing tool</p>																					
	<p>Patch A</p> 																						
	<p>Patch B</p> 																						
	<p>Spacer cylinder</p> 																						
<p>Insertion guide and extraction seal</p> 																							
<table border="1" data-bbox="430 1836 925 2016"> <thead> <tr> <th rowspan="2">Model</th> <th colspan="4">Size</th> <th rowspan="2">Code No.</th> </tr> <tr> <th>A</th> <th>B</th> <th>C</th> <th>D</th> </tr> </thead> <tbody> <tr> <td>YSM8</td> <td>44</td> <td>48</td> <td>21</td> <td>21</td> <td>104100~92410</td> </tr> <tr> <td>YSM12</td> <td>52</td> <td>57</td> <td>23.5</td> <td>25.5</td> <td>103338~92410</td> </tr> </tbody> </table>	Model	Size				Code No.	A	B	C	D	YSM8	44	48	21	21	104100~92410	YSM12	52	57	23.5	25.5	103338~92410	
Model		Size					Code No.																
	A	B	C	D																			
YSM8	44	48	21	21	104100~92410																		
YSM12	52	57	23.5	25.5	103338~92410																		

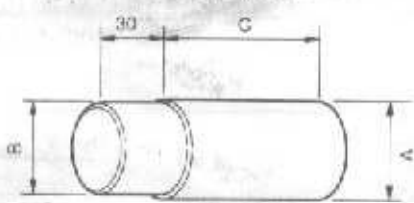
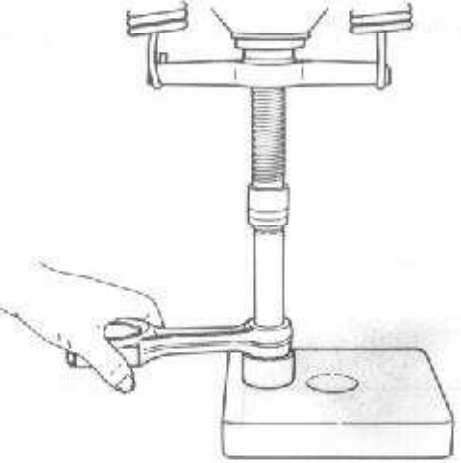
Name of hand tool	Shape and size	Application
Crankshaft bearing metal replacing tool (made to special order)	<p>Insertion guiding and extracting bolt</p>  <p>Hexagon nut</p>  <p>Code no. 26716-16002</p>  <p>Code no. 26756-16002</p>	

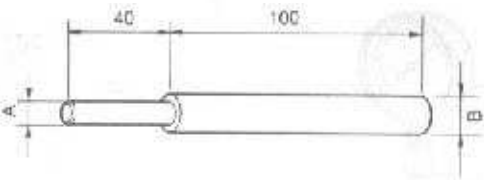
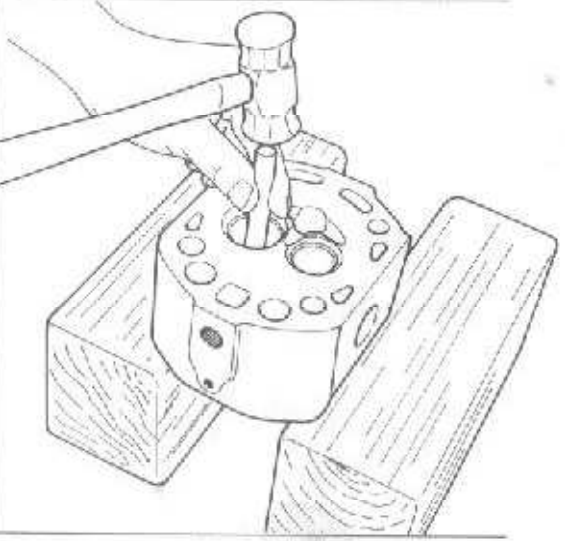
Inserting and extracting tool for bush of small end of connecting rod (commercially available product)	 <table border="1" data-bbox="391 1310 933 1467"> <thead> <tr> <th rowspan="2">Model</th> <th colspan="3">Size</th> <th rowspan="2">Code No.</th> </tr> <tr> <th>A</th> <th>B</th> <th>C</th> </tr> </thead> <tbody> <tr> <td>YSM8</td> <td><math>\phi 25_{-0.5}^{0.2}</math></td> <td><math>\phi 23_{-0.1}^0</math></td> <td>85</td> </tr> <tr> <td>YSM12</td> <td><math>\phi 31_{-0.5}^{0.2}</math></td> <td><math>\phi 28_{-0.1}^0</math></td> <td>60</td> </tr> </tbody> </table> <p style="text-align: right;">mm</p>	Model	Size			Code No.	A	B	C	YSM8	$\phi 25_{-0.5}^{0.2}$	$\phi 23_{-0.1}^0$	85	YSM12	$\phi 31_{-0.5}^{0.2}$	$\phi 28_{-0.1}^0$	60	
Model	Size			Code No.														
	A	B	C															
YSM8	$\phi 25_{-0.5}^{0.2}$	$\phi 23_{-0.1}^0$	85															
YSM12	$\phi 31_{-0.5}^{0.2}$	$\phi 28_{-0.1}^0$	60															

Inserting and extracting tool for intake and exhaust valve guide (commercially available product)	 <table border="1" data-bbox="391 1848 933 2004"> <thead> <tr> <th rowspan="2">Model</th> <th colspan="2">Size</th> <th rowspan="2">Code No.</th> </tr> <tr> <th>A</th> <th>B</th> </tr> </thead> <tbody> <tr> <td></td> <td><math>\phi 7_{-0.2}^{0.1}</math></td> <td><math>\phi 11.5_{-0.05}^0</math></td> </tr> <tr> <td>YSM12</td> <td><math>\phi 8_{-0.2}^{0.1}</math></td> <td><math>\phi 12.5_{-0.05}^0</math></td> </tr> </tbody> </table> <p style="text-align: right;">mm</p>	Model	Size		Code No.	A	B		$\phi 7_{-0.2}^{0.1}$	$\phi 11.5_{-0.05}^0$	YSM12	$\phi 8_{-0.2}^{0.1}$	$\phi 12.5_{-0.05}^0$	
Model	Size		Code No.											
	A	B												
	$\phi 7_{-0.2}^{0.1}$	$\phi 11.5_{-0.05}^0$												
YSM12	$\phi 8_{-0.2}^{0.1}$	$\phi 12.5_{-0.05}^0$												

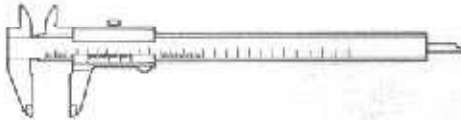
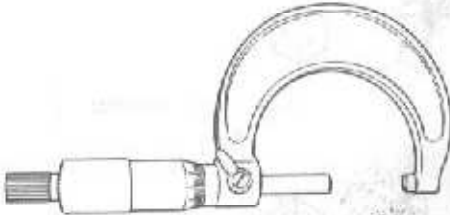
2-3 Measuring instruments

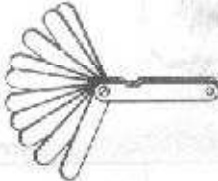
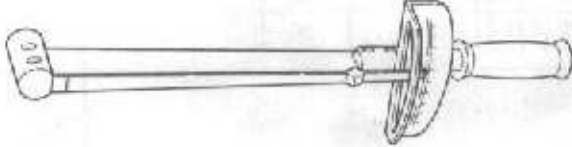
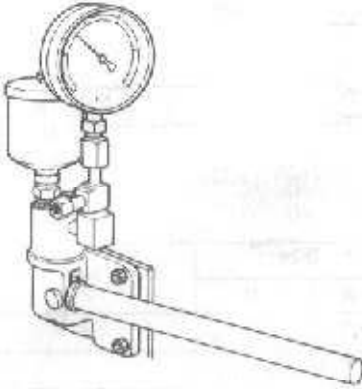
Nomenclature		Accuracy and range
Vernier calipers		1/20 mm, 0 ~ 150 mm,
Micrometer		1/100 mm, 0 ~ 25 mm, 25 ~ 50 mm, 50 ~ 75 mm, 75 ~ 100 mm,
Cylinder gauge		1/100 mm, 18 ~ 35 mm, 35 ~ 60 mm, 50 ~ 100 mm,
Thickness gauge		0.05 ~ 2 mm,
Torque wrench		0 ~ 13 kg-m.
Nozzle tester		0 ~ 500 kg/cm <sup>2</sup> .

### 3. Other

#### Supplementary packing agent



Type	Use
"Three Bond 3B8-005"	White. Since "Three Bond 3B8-005" is a nonorganic solvent, it does not penetrate asbestos sheets made principally of or completely of asbestos. Always use it with grey asbestos sheet packing for complete oiltightness. When "Three Bond 3B8-005" is difficult to obtain, use silicone nonsolvent type "Three Bond No. 50."
"Three Bond No. 50"	Grey. Silicone nonsolvent type liquid packing. Semidry type packing agent coated on mating faces to prevent oil and gas leakage. Does not penetrate asbestos sheet and assures complete oiltightness.
"Three Bond No. 1"	Reddish brown. Paste type wet viscous liquid packing. Ideal for mating faces which are removed but reinstalled. Particularly used to prevent water leakage and to prevent seizing of bolts and nuts.

The surface to be coated must be thoroughly cleaned with thinner or benzene and completely dry. Moreover, coating must be thin and uniform.

Products of Three Bond Co., Ltd.

#### Paint



Color spray

Metallic Ecote Silver is used entirely on this engine.

Wipe off the surface to be painted with thinner or benzene, shake the spray can well, push the button at the top of the can and spray the paint onto the surface from a distance of 30 ~ 40 cm.

#### Paint

##### Type

White paint  
(Mixed oil paint)

##### Usage point

Cylinder liner  
insertion hole

##### Use

Paint parts that contact the cylinder body when inserting the cylinder liner to prevent rusting and water leakage.

#### Yanmar cleaner

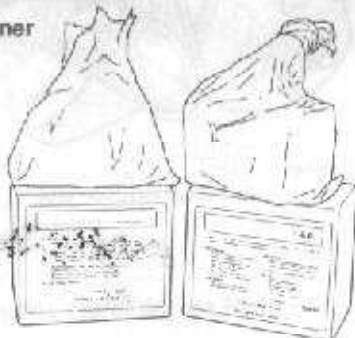

Cooling passage cleaner is made by adding one part "Unicon 146" to about 16 parts water (specific gravity ratio). To use, drain the water from the cooling system, fill the system with cleaner, allowing it to stand overnight (10 ~ 15 hours). Then drain out the cleaner, fill the system with water, and operate the engine for at least one hour.

#### NEJI LOCK SUPER 203M: a locking agent for screws



For coating on screws and bolts to prevent loosening, rusting, and leaking. To use, wipe off all oil and water on the threads of studs, coat the threads with screw lock, tighten the stud bolt, and allow to stand until the screw lock hardens. Use screw lock on the oil intake pipe threads, oil pressure switch threads, fuel injection timing shim faces, and front axle bracket mounting bolts.

## 4. Disassembly

**NOTE:** When disassembling this machine, ascertain the cause of trouble; neither remove nor disassemble parts when it is unnecessary.

1. Remove the wiring from each part taking note of its color coding.
2. Remove the alternator.
3. Remove the bracket.
4. Remove the starter.

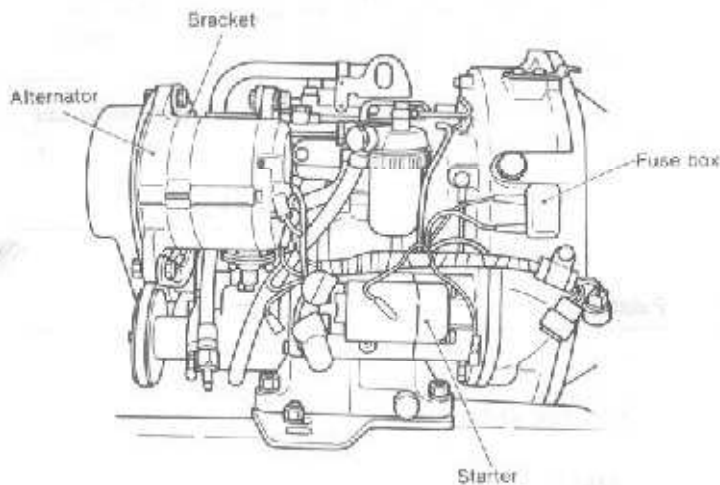

5. Remove the blow-by pipe from the intake silencer side only.
6. Remove the intake silencer paying close attention to the packing.

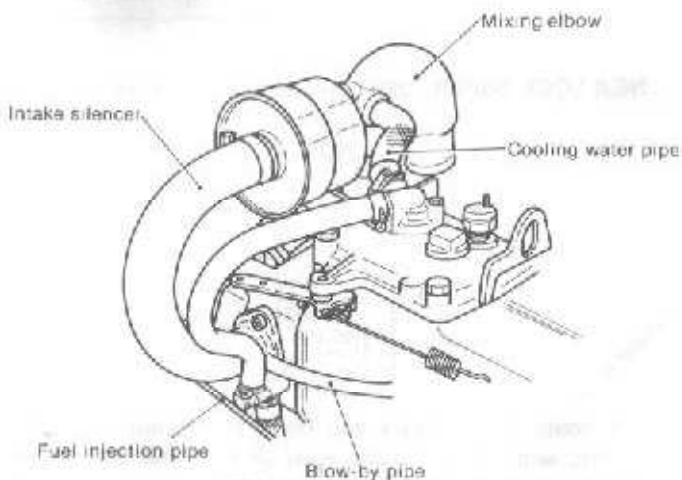

7. Remove the cooling water pipe which is installed between the mixing elbow and the block.

8. Remove the mixing elbow. Stainless steel bolt.

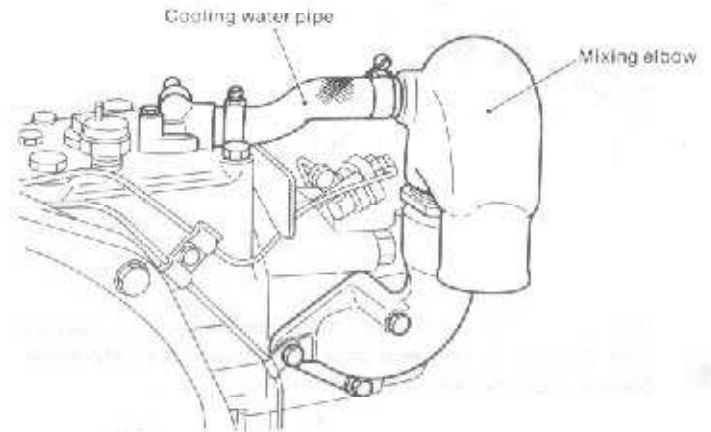

9. Remove the fuel injection pipe.
10. Remove the fuel return pipe.
11. By removing the fuel injection valve clamp remove the fuel injection valve.  
• Note the face and back side of the clamp.
12. Remove the rocker chamber.

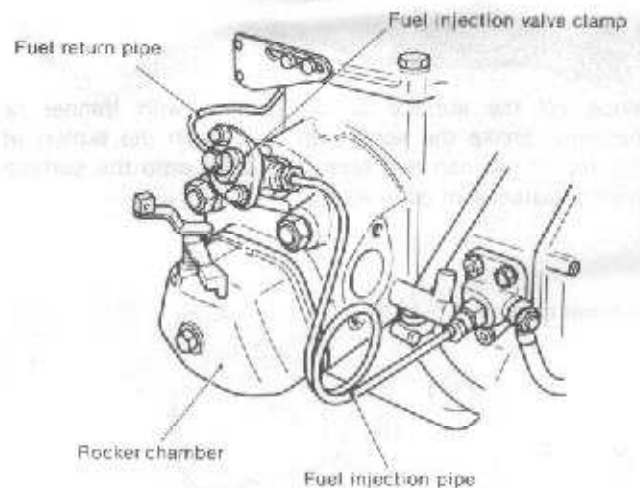

13. Remove the support for the intake and exhaust valve arm.
14. Remove the cap for the intake and exhaust valve. Be careful not to lose it.
15. Remove the push rod.
16. Remove the coupling bolt of the lubricating oil pipe for the cylinder head.
17. Remove the cooling water pipe from the head side only.

18. Remove the cylinder head.

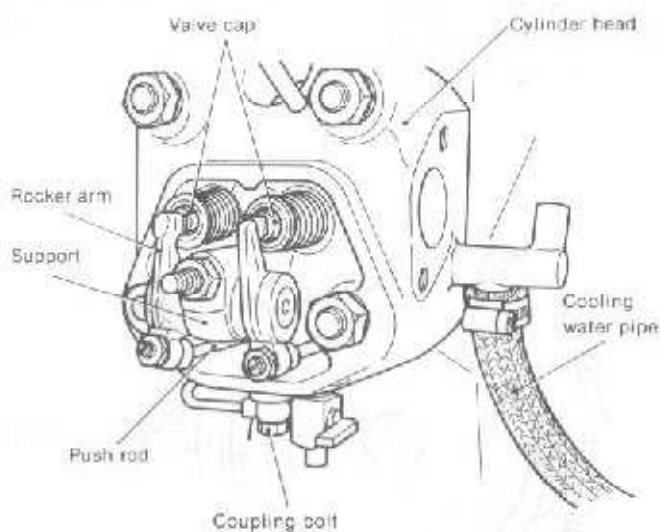

19. Remove the gasket packing.  
 • Note the face and back side of the packing.  
 20. Remove the cooling water pump along with the cooling water pipe.  
 21. Remove the fuel oil pipe from the pump side only.  
 22. Extract the engine oil.  
 23. Remove the side cover along with the oil gauge rod.

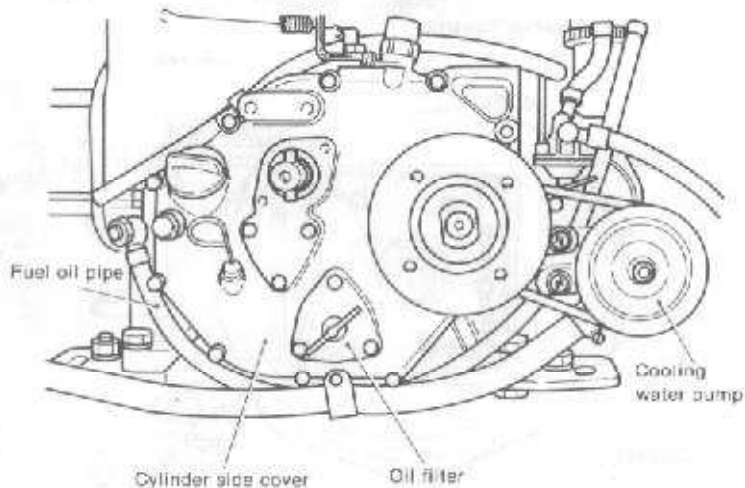

24. Remove the fuel oil pump. Be careful not to injure the regulator plate.  
 25. Remove the No. 1 and No. 2 levers for the governor.  
 • They can be removed by extracting the taper pin.  
 • Also remove the regulator spring.  
 • Be careful not to lose the dust-proof cap.

26. Remove the governor spindle support.

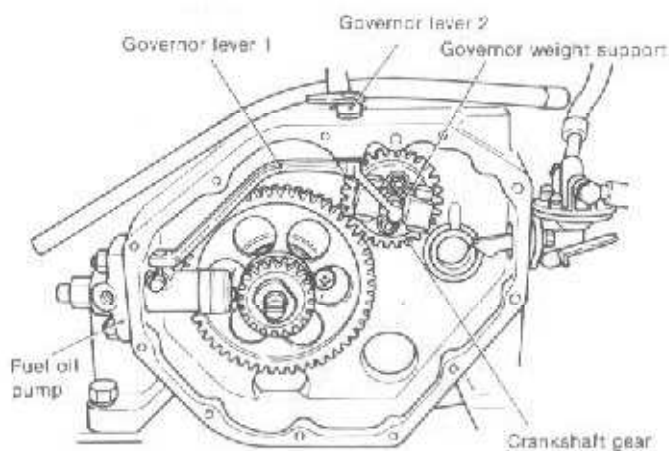

27. Remove fuel oil pipe (B), (which is installed between the filter and the feed pump).  
 28. Remove the feed pump. Be careful not to damage the packing.  
 29. Remove the fuel filter bracket.  
 30. Remove the cylinder rear cover along with the blow-by pipe.  
 31. Remove the lubricating oil pipe.

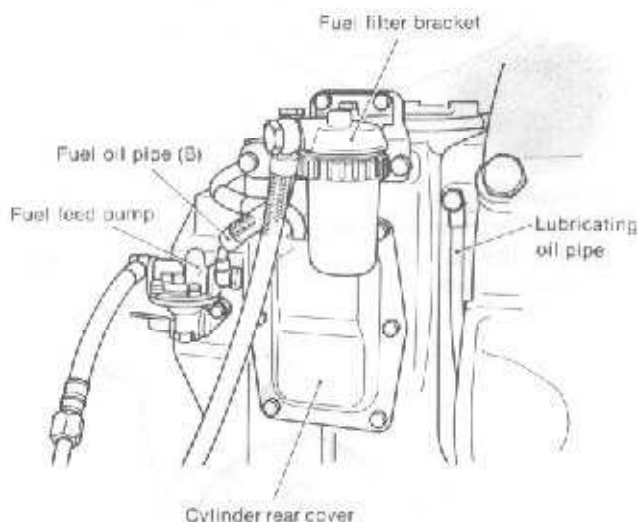

32. Remove the neutral adjusting screw.  
 33. Remove the forward shaft rear box lid.  
 34. Remove the engine leg.

35. Remove the clutch case.

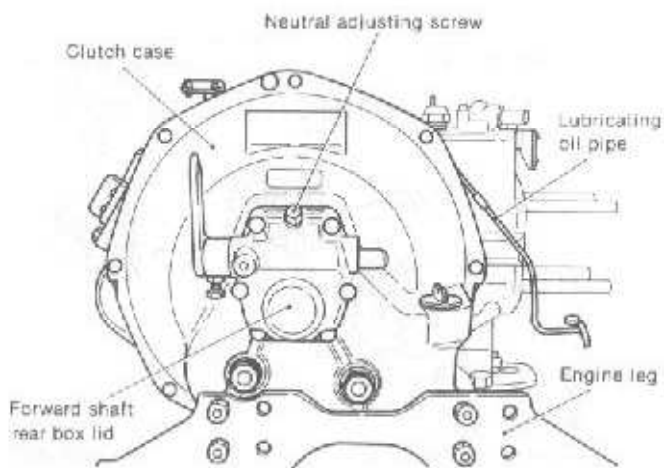

36. Remove the clutch.

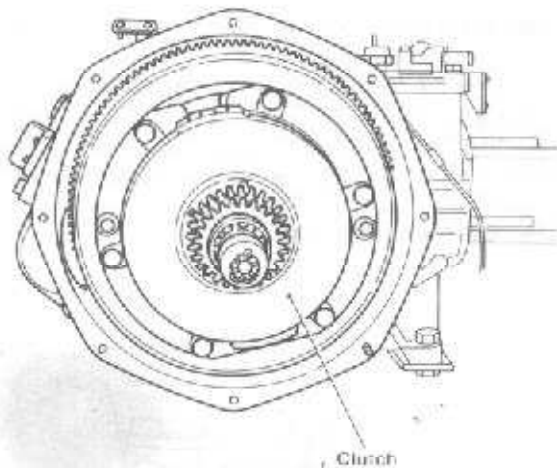

37. Remove the piston.

1. Remove the connecting rod bolt.
2. Align the T.D. mark on the flywheel with the flywheel housing mark.

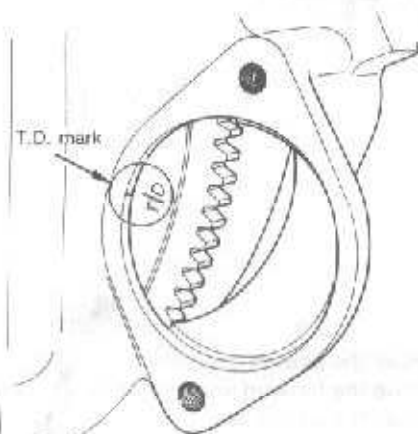

3. Extract the piston.

- Remove the carbon sticking to the upper part of the cylinder liner. The piston can be pulled out without difficulty.

38. Remove the end nut.
39. Remove the flywheel.

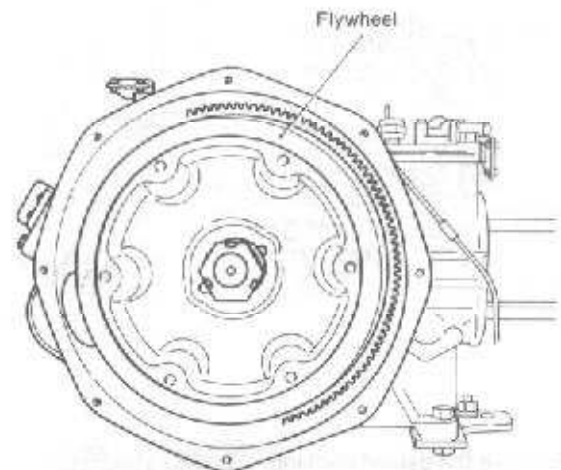

40. Remove the flywheel key.
41. Remove the flywheel housing. Be careful not to lose the clutch breather.

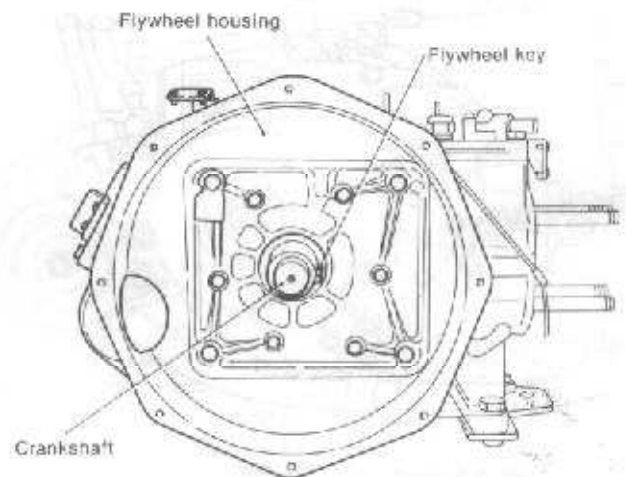

42. Remove the crankshaft.
  - Place the balancing weight at the cylinder block extracting position.
  - Be careful not to damage the thrust bearing metal.
  - Along with the crankshaft gear.
43. Extract the camshaft bearing retaining bolt.
44. Extract the camshaft.

45. Extract the tappet.

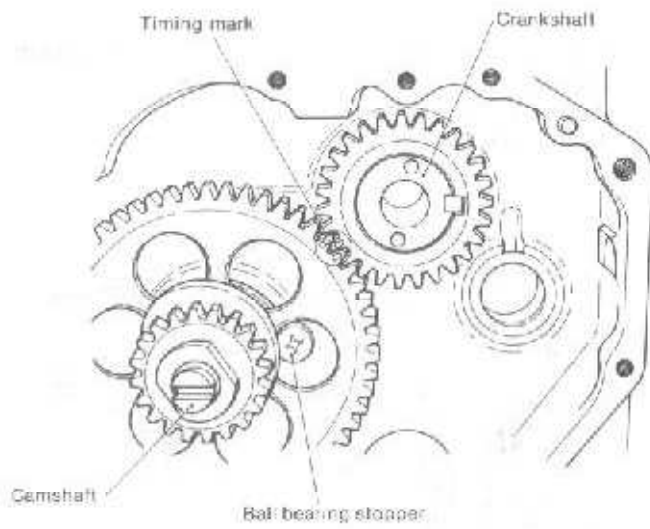



## 5. Reassembly

1. Insert the tappet.
2. Attach the camshaft.
3. Attach the clamp bolt for camshaft bearings.
4. Attach the thrust bearing for camshaft (the oil groove of the bearing is directed toward the camshaft side).

8. Mount the flywheel key. Don't forget the clutch breather.
9. Attach the flywheel.
10. Tighten the end nut.

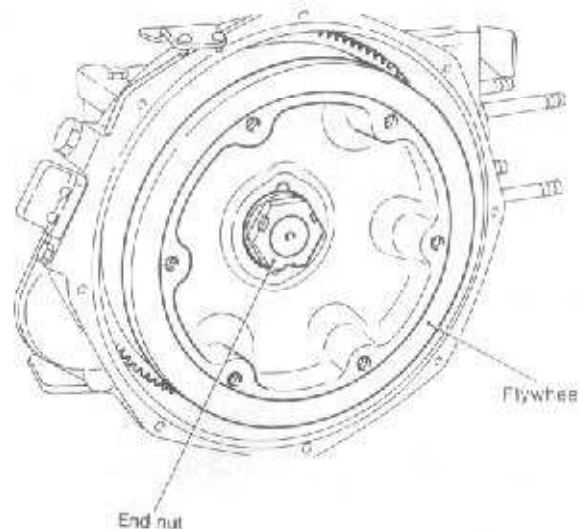
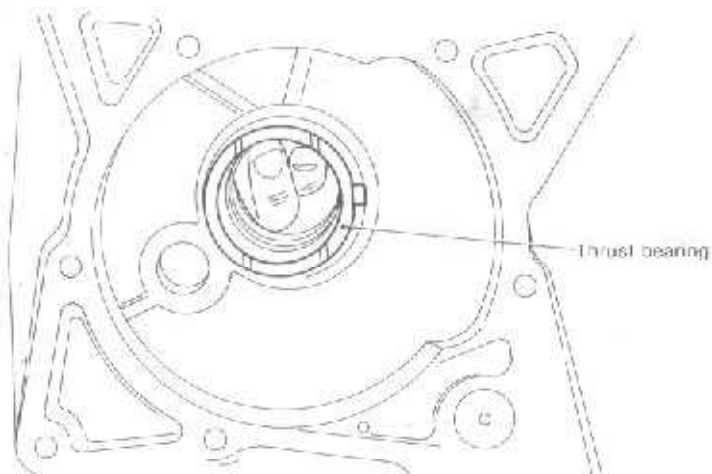

5. Attach the crankshaft. Be careful not to drop or damage the bearing.
6. Attach the flywheel housing.

	kg·m	
	YSM8	YSM12
Tightening torque	27	35

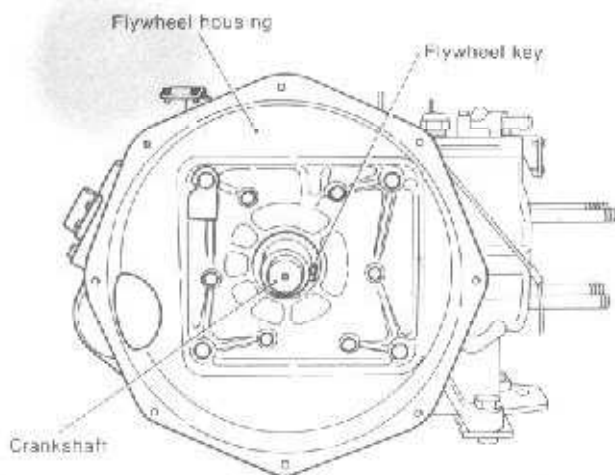

11. Secure the piston in place:

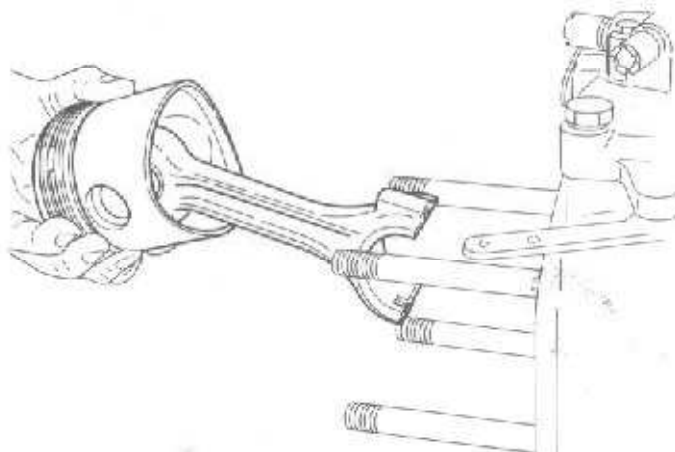

	kg·m	
Tightening torque	Spanner 13	Spanner 17
	2.5	4.7

7. Check the crankshaft side gap.  
Be sure that the bearing barrel packing is of standard type and brand new.

1. Position → the piston ring end.

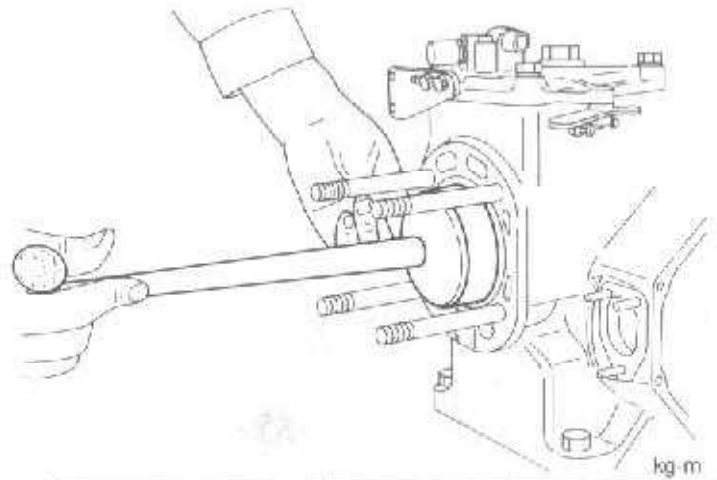
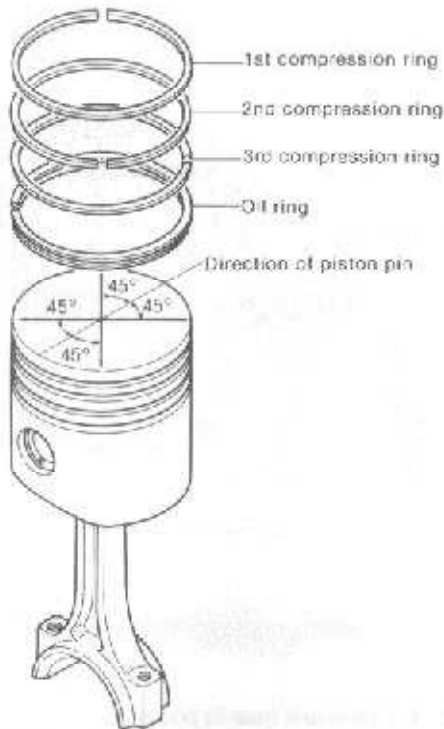

	YSMB	YSM12
Tightening torque for connecting rod clamp bolt	4	5.5

2. Align the TD mark of the flywheel.

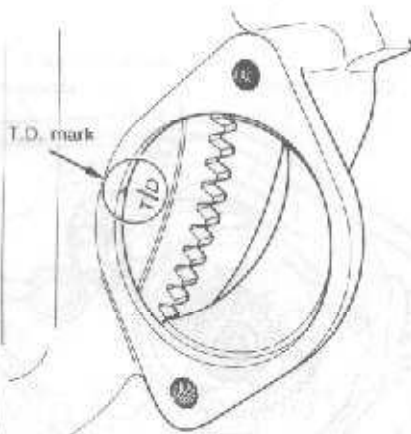

12. Attach the clutch.

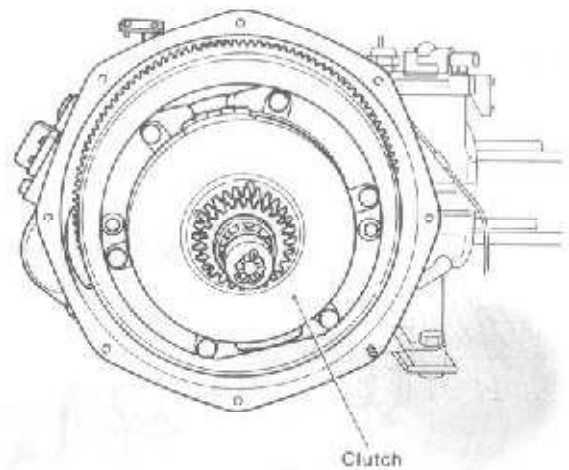

	kg-m
Tightening torque	YSMB, 12 4.4 to 5.0

13. Attach the clutch case.

	kg-m
Tightening torque	YSMB, 12 2.3 to 2.7

3. Insert the piston and secure it in place.

- Lubricate the outer surface of the piston and the crank pin bearing metal.
- Turn up the No. on the big end of the connecting rod assemble No. together.
- Apply turve paste to the threads of the connecting rod clamp bolt and tighten the clamp bolt uniformly.

14. Attach the engine leg.

15. Attach the lid of the forward shaft rear box.

16. Attach the neutral adjusting screw.
- Do not tighten the screw.
  - Lock the adjusting screw in the position where the propeller shaft will not rotate when the handle is set in the neutral position during operation.

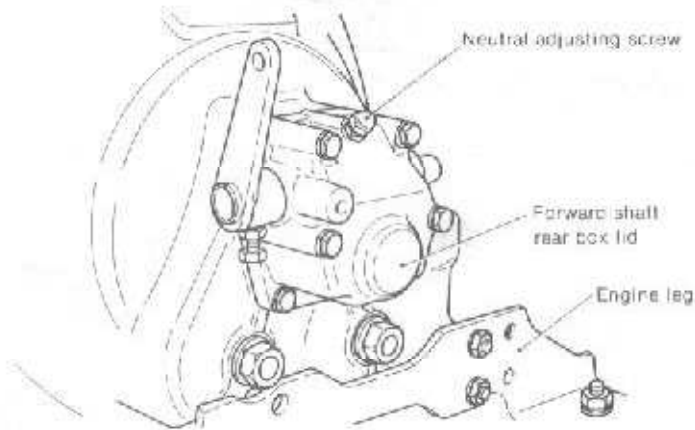

17. Attach the lubricating oil pipe.

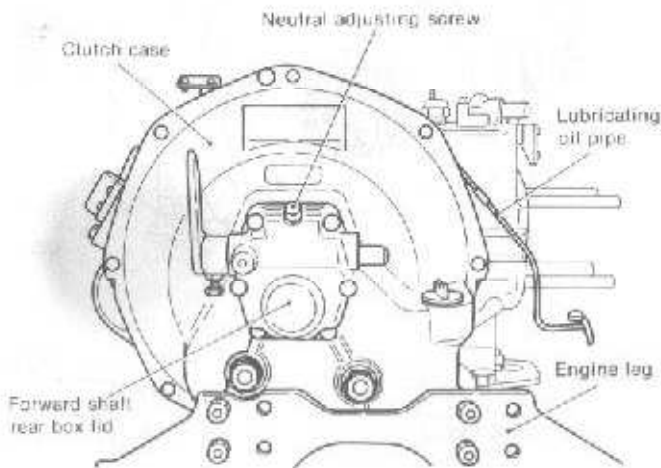

18. Attach the rear lid of the cylinder.  
19. Attach the fuel oil filter bracket.  
20. Attach the feed pump.
- Note how the packing is placed.

21. Attach the fuel oil pipe (B).

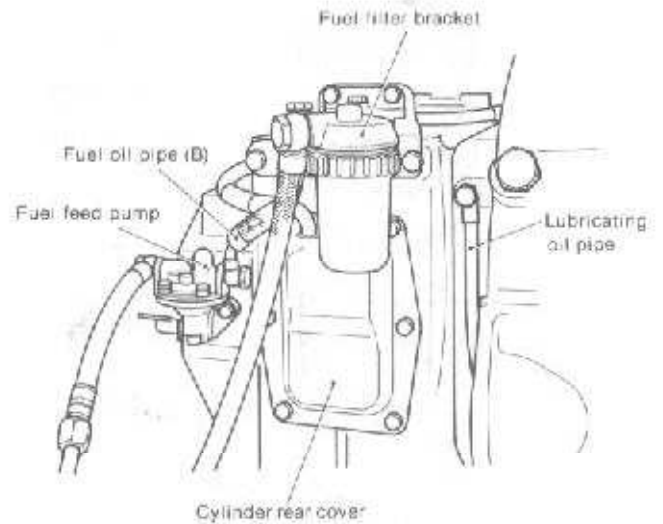

22. Fit the crank gear in position.  
Align the matching mark of the camshaft gear.  
23. Attach the governor support spindle.  
24. Attach the No.1 and No.2 levers for governor.
- Don't forget the dustproof cap.
  - Install the shorter hook of the regulator spring on the right side.

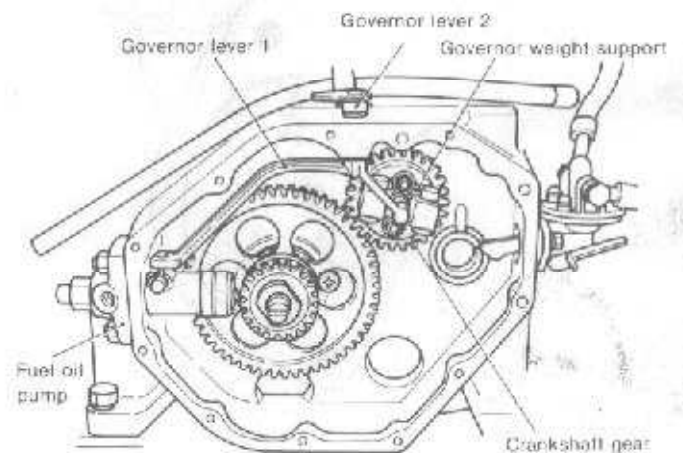

25. Attach the fuel oil pump.
  - Be careful not to injure the regulator plate.
  - Align the rack with the No.2 lever for the governor.

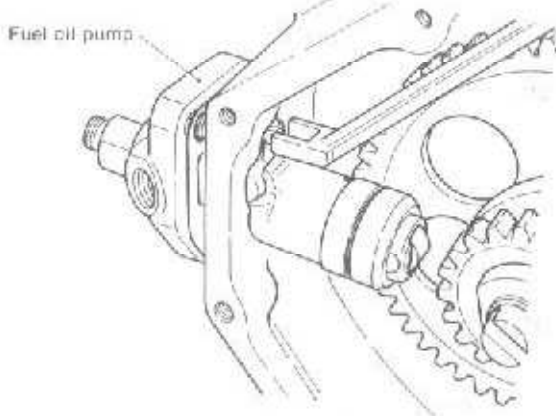

26. Attach the side cover
  - Along with the oil gauge rod.
27. Attach the fuel oil pipe.
  - On the pump side only.
28. Attach the cooling water pump.
  - Drive-belt deflection: 5 to 7 mm
  - The brand name indicated on the belt should rotate in the direction of pulley rotation.
29. Attach the gasket packing.
  - Note the face and back side of the packing.
30. Attach the cylinder head.

	kg-m	
	YSM8	YSM12
Tightening torque	9.7	13.6

31. Attach the cooling water pipe.
  - On the head side only.
32. Attach the coupling bolt of the lubricating oil pipe for the cylinder head.
33. Attach the push rod.
34. Attach the intake and exhaust valve cap.
35. Attach the rocker arm and support for the intake and exhaust valve.
  - Be careful not to drop the cap and push rod.
  - Be sure that the rocker arm is in proper contact with the valve head.

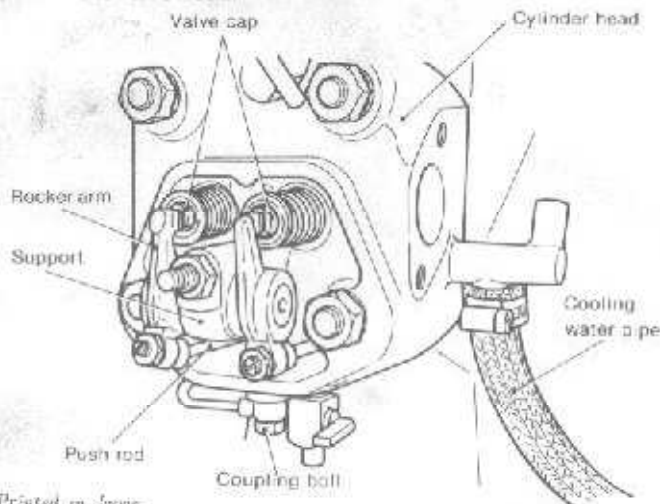

36. Adjust the top clearance of the intake and exhaust valve.

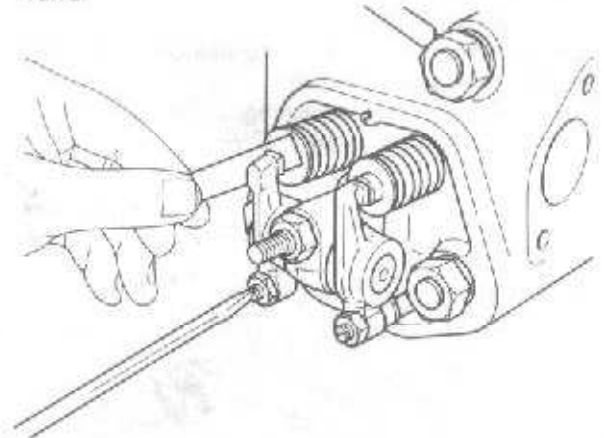

- Top clearance when intake and exhaust valve head is cold: 0.2 mm
- Adjust the clearance by means of compression T.D.

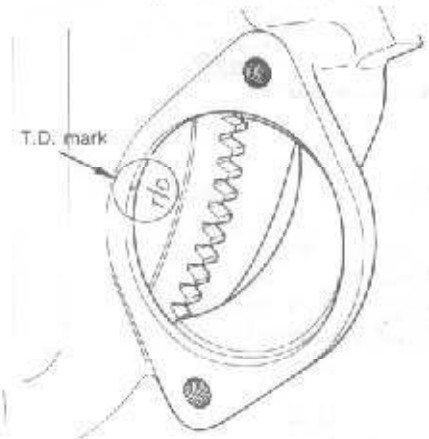

	kg-m	
	2	
Tightening torque		

37. Attach the bonnet
38. Attach the fuel injection valve.
  - Note the face and back side of the valve holder.
39. Attach the fuel return pipe.
40. Attach the fuel injection pipe.

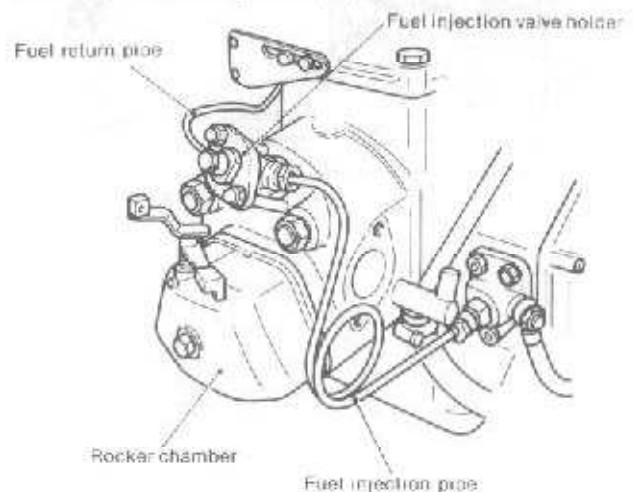

41. Attach the silencer.
  - Use specially treated SCM bolts.
42. Attach the cooling water pipe.
  - For the section between the silencer and the block.
43. Attach the intake silencer.
  - Pay attention to the packing.
44. Attach the blow-by pipe.

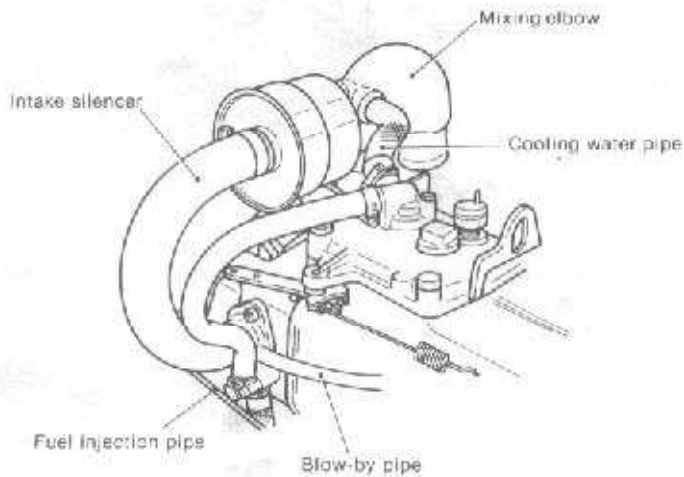

- On the silencer side.
45. Attach the starter.
  46. Attach the bracket.
  47. Attach the alternator.
    - Deflection of the drive-belt
  48. Install the wiring for each section.

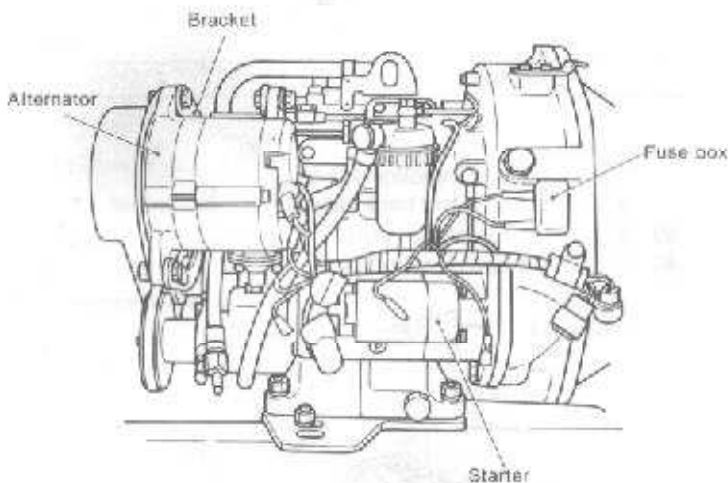

## 6. Tightening Torque

The bolts and nuts used in this engine employ ISO general metric threads stipulated in JIS (Japanese Industrial Standards). Pay careful attention to the thread dimensions

when replacing bolts and nuts.

Tighten the bolts and nuts to the tightening torque given in the table below.

### 6-1 Main bolt and nut tightening torque.

Bolt/nut	Engine name YSM	Thread diameter	Width across flats	Tightening torque (kg-cm)
Flywheel housing mounting bolt.	8.12	M8	13	250
Flywheel housing mounting bolt	8.12	M10	17	470
Connecting rod bolt.	8			400
Connecting rod bolt.	12			550
Cylinder head tightening nut.	8			970
Cylinder head tightening nut.	12			1,360
End nut.	8			2,700
End nut.	12			3,500
Case cover assembly mounting nut.	8.12	M6	10	80 ~ 100
Intake/exhaust valve rocker arm assembly mounting nut.	8.12	M10	17	360 ~ 380
Intake/exhaust valve clearance adjusting screw fixing nut.	8.12	M8	13	200
Cylinder rear cover mounting bolt.	8.12	M6	10	80 ~ 100
Reversing device assembly mounting bolt.	8.12	M10	17	440 ~ 500
Reversing device friction disk housing bolt.	8.12	M8	13	230 ~ 270
Clutch case mounting bolt and nut.	8.12	M8	13	230 ~ 270
Forwarding shaft rear box assembly mounting bolt.	8.12	M6	13	230 ~ 270
Valve rocker arm assembly mounting bolt	8.12	M6	13	190 ~ 210

### 6-2 General bolt and nut tightening torque

#### (1) Hex bolts

Thread diameter	Width across flats	Tightening torque, kg-m	
		4T bolts	7T bolts
M5 × 0.2	9	0.2 ~ 0.3	0.3 ~ 0.5
M6 × 1.0	10	0.4 ~ 0.7	0.8 ~ 1.2
M8 × 1.25	13	1.0 ~ 1.6	2.0 ~ 3.0
M10 × 1.5	17	1.8 ~ 3.0	3.7 ~ 5.2
M12 × 1.25	19	3.5 ~ 5.5	7.5 ~ 10.0

#### (2) Pipe joint bolts

Thread diameter	Width across flats	Tightening torque, kg-m
M8 × 1.25	13	1.2 ~ 1.7
M12 × 1.25	17	2.5 ~ 3.0
M14 × 1.5	19	4.0 ~ 5.0
M16 × 1.5	22	5.0 ~ 6.0

## 7. Packing Supplement and Adhesive Application Points

The packing used in this engine is asbestos sheet sealed at both mating faces.

Be sure to use the correct supplement in accordance with the below table.

Be sure to remove the grease, and the adhesive, before applying new packing agents or adhesives.

Location applied	Name of packing agent and adhesive
The circumference of cylinder liner, inserted portion, O-ring portion	White oil paint
Cylinder head fixing bolt	Three Bond No.1
Feed pump bolt	Neji Lock Super 203M
Screw and washer for connecting rod bolt	Paste
Drain pipe	Neji Lock Super 203M
Cooling water pipe joint (head side)	Neji Lock Super 203M
Clutch case bolt (stud bolt)	Neji Lock Super 203M
Engine foot bolt	Neji Lock Super 203M